

SERVICE MANUAL

MODEL: LAN5200WR1

SERVICE MANUAL

CAR NAVIGATION SYSTEM

MODEL: LAN5200WR1

www.electronicsrepair.net

RENAULT

RENAULT

CONTENTS

SECTION 1 SUMMARY

SERVICING PRECAUTIONS	1-2
ESD PRECAUTIONS	1-3
SPECIFICATIONS	1-4

SECTION 2 ELECTRICAL

ELECTRICAL TROUBLESHOOTING GUIDE.....	2-1
1. FRONT PART	2-1
2. AUDIO PART	2-2
3. POWER PART	2-6
4. GPS PART	2-8
CONNECTOR TERMINAL FUNCTION	2-10
WAVEFORMS.....	2-13
CIRCUIT VOLTAGE CHART	2-15
BLOCK DIAGRAMS	2-33
1. FUNCTION BLOCK DIAGRAM.....	2-33
2. H/W BLOCK DIAGRAM	2-35
3. S/W BLOCK DIAGRAM	2-37
4. FRONT BLOCK DIAGRAM.....	2-39
5. AUDIO BLOCK DIAGRAM.....	2-41
6. POWER BLOCK DIAGRAM.....	2-43
7. GPS BLOCK DIAGRAM.....	2-45
CIRCUIT DIAGRAMS	2-47
1. FRONT CIRCUIT DIAGRAM	2-47
2. MAIN - POWER + AMPLIFIER CIRCUIT DIAGRAM	2-49
3. MAIN - SINGLE RF TUNER(LEAF DICE) CIRCUIT DIAGRAM.....	2-51
4. MAIN - DSP(DiRaNa2) CIRCUIT DIAGRAM.....	2-53
5. MAIN - MICOM + CAN CIRCUIT DIAGRAM.....	2-55
6. MAIN - DAB CIRCUIT DIAGRAM.....	2-57
7. MAIN - AU1320 LCD & USB & UART CIRCUIT DIAGRAM.....	2-59
8. MAIN - AU1320 BUS & PSC CIRCUIT DIAGRAM.....	2-61
9. MAIN - AU1320 VDD & BOOT & RESET / IPOD CP CIRCUIT DIAGRAM	2-63
10. MAIN - DDR2 SDRAM CIRCUIT DIAGRAM	2-65
11. MAIN - NOR FLASH & i-NAND CIRCUIT DIAGRAM.....	2-67
12. MAIN - VIDEO DECODER & USB CIRCUIT DIAGRAM	2-69
13. MAIN - CONNECTOR & DEBUG CIRCUIT DIAGRAM.....	2-71
14. MAIN - GPS CIRCUIT DIAGRAM.....	2-73
PRINTED CIRCUIT BOARD DIAGRAMS	2-75
1. FRONT P.C.BOARD	2-75
2. MAIN P.C.BOARD	2-79

SECTION 3 EXPLODED VIEW

1. CABINET AND MAIN FRAME SECTION	3-1
---	-----

SECTION 4 REPLACEMENT PARTS LIST

SECTION 1 SUMMARY

SERVICING PRECAUTIONS

1. Always disconnect the power source before:

- 1) Removing or reinstalling any component, circuit board, module or any other instrument assembly.
- 2) Disconnecting or reconnecting any instrument electrical plug or other electrical connection.
- 3) Connecting a test substitute in parallel with an electrolytic capacitor in the instrument.

CAUTION: A wrong part substitution or incorrect polarity installation of electrolytic capacitors may result in an explosion hazard.

2. Do not defeat any plug/socket B+ voltage interlocks with which instruments covered by this service manual might be equipped.

3. Do not apply power to this instrument and or any of its electrical assemblies unless all solid-state device heat sinks are correctly installed.

4. Always connect a test instrument's ground lead to the instrument chassis ground before connecting the test instrument positive lead. Always remove the test instrument ground lead last.

- 1) The service precautions are indicated or printed on the cabinet, chassis or components. When servicing, follow the printed or indicated service precautions and service materials.
- 2) The Components used in the unit have a specified conflammability and dielectric strength. When replacing any components, use components which have the same ratings. Components marked in the circuit diagram are important for safety or for the characteristics of the unit. Always replace with the exact components.
- 3) An insulation tube or tape is sometimes used and some components are raised above the printed writing board for safety. The internal wiring is sometimes clamped to prevent contact with heating components. Install them as they were.
- 4) After servicing always check that the removed screws, components and wiring have been installed correctly and that the portion around the service part has not been damaged. Further check the insulation between the blades of attachment plug and accessible conductive parts.

ESD PRECAUTIONS

Electrostatically Sensitive Devices (ESD)



Some semiconductor (solid state) devices can be damaged easily by static electricity. Such components commonly are called electrostatically sensitive devices (ESD). Examples of typical ESD devices are integrated circuits and some field-effect transistors and semiconductor chip components. The following techniques should be used to help reduce the incidence of component damage caused by static electricity.

1. Immediately before handling any semiconductor component or semiconductor-equipped assembly, drain off any electrostatic charge on your body by touching a known earth ground. Alternatively, obtain and wear a commercially available discharging wrist strap device, which should be removed for potential shock reasons prior to applying power to the unit under test.
2. After removing an electrical assembly equipped with ESD devices, place the assembly on a conductive surface such as aluminum foil, to prevent electrostatic charge buildup or exposure of the assembly.
3. Use only a grounded-tip soldering iron to solder or unsolder ESD devices.
4. Use only an anti-static solder removal device. Some solder removal devices not classified as "anti-static" can generate electrical charges sufficient to damage ESD devices.
5. Do not use freon-propelled chemicals. These can generate electrical charges sufficient to damage ESD devices.
6. Do not remove a replacement ESD device from its protective package until immediately before you are ready to install it. (Most replacement ESD devices are packaged with leads electrically shorted together by conductive foam, aluminum foil or comparable conductive materials).
7. Immediately before removing the protective material from the leads of a replacement ESD device, touch the protective material to the chassis or circuit assembly into which the device will be installed.

CAUTION : BE SURE NO POWER IS APPLIED TO THE CHASSIS OR CIRCUIT, AND OBSERVE ALL OTHER SAFETY PRECAUTIONS.

8. Minimize bodily motions when handling unpackaged replacement ESD devices. (Otherwise harmless motion such as the brushing together of your clothes fabric or the lifting of your foot from a carpeted floor can generate static electricity sufficient to damage an ESD device).

CAUTION. GRAPHIC SYMBOLS

	THE LIGHTNING FLASH WITH ARROWHEAD SYMBOL, WITHIN AN EQUILATERAL TRIANGLE, IS INTENDED TO ALERT THE SERVICE PERSONNEL TO THE PRESENCE OF UNINSULATED "DANGEROUS VOLTAGE" THAT MAY BE OF SUFFICIENT MAGNITUDE TO CONSTITUTE A RISK OF ELECTRIC SHOCK.
	THE EXCLAMATION POINT WITHIN AN EQUILATERAL TRIANGLE IS INTENDED TO ALERT THE SERVICE PERSONNEL TO THE PRESENCE OF IMPORTANT SAFETY INFORMATION IN SERVICE LITERATURE.

SPECIFICATION

GENERAL

Output Power	47 W x 4 CH (Max.)
Power Source	DC 13.8 V
Speaker impedance	4 Ω
Ground System	Negative
Dimensions (W x H x D)	212.37 x 126.16 x 183.5 mm
Net Weight.....	1.4 kg

DISPLAY

LCD	7 inch touch screen LCD display
Resolution	800 x 480
Back Light.....	LED type

RADIO SELECTION

FM

Frequency Range	87.5 - 108 MHz
S/N Ratio	57 dB
Distortion	0.35 %
Usable Sensitivity	6 dB μ V

AM

Frequency Range	522 - 1,620 kHz
S/N Ratio	68 dB(MW, LW)
Distortion	0.3 % (LW), 0.2 % (MW)
Usable Sensitivity	20 dB μ V

NAVIGATION SELECTION

CPU	AU1320
OS	WINCE7.0
SDRAM	256 MB
Memory (Map)	4 GB NANDrive (NAND Flash)
Memory (OS).....	32 Mbit NOR Flash
GPS	UBLOX
Map	NNG
User Interface.....	Touch screen

SECTION 2 ELECTRICAL

ELECTRICAL TROUBLESHOOTING GUIDE

1. FRONT PART

• FRONT_LCD ERROR

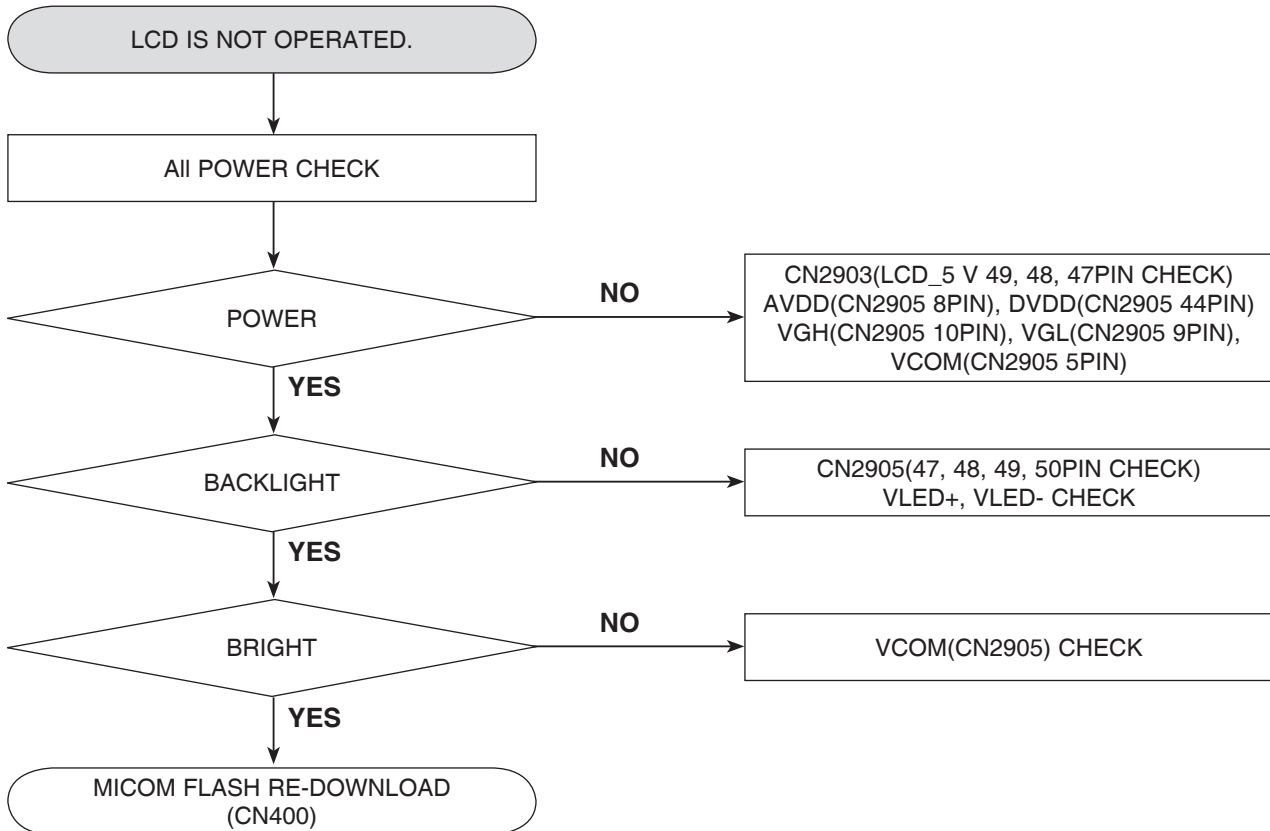

• FRONT_TOUCH ERROR

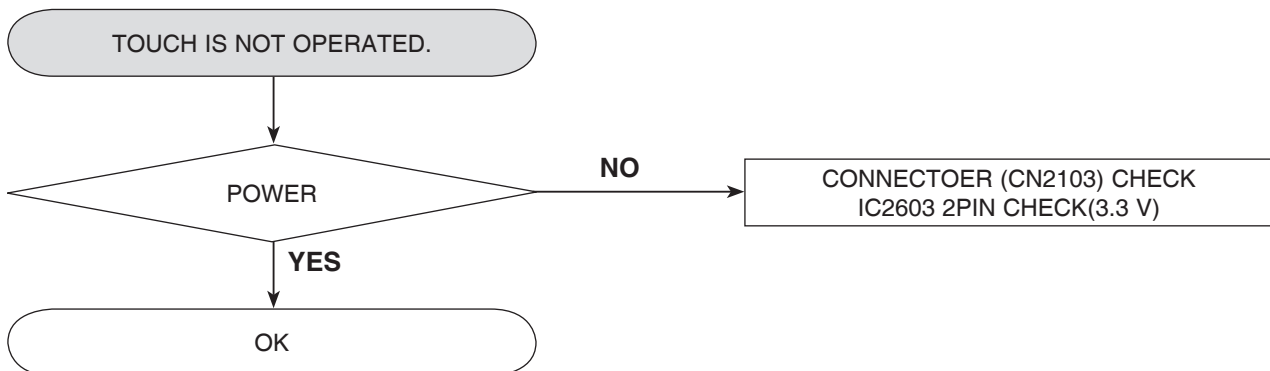

2. AUDIO PART

• AUDIO MICOM OPERATING ERROR

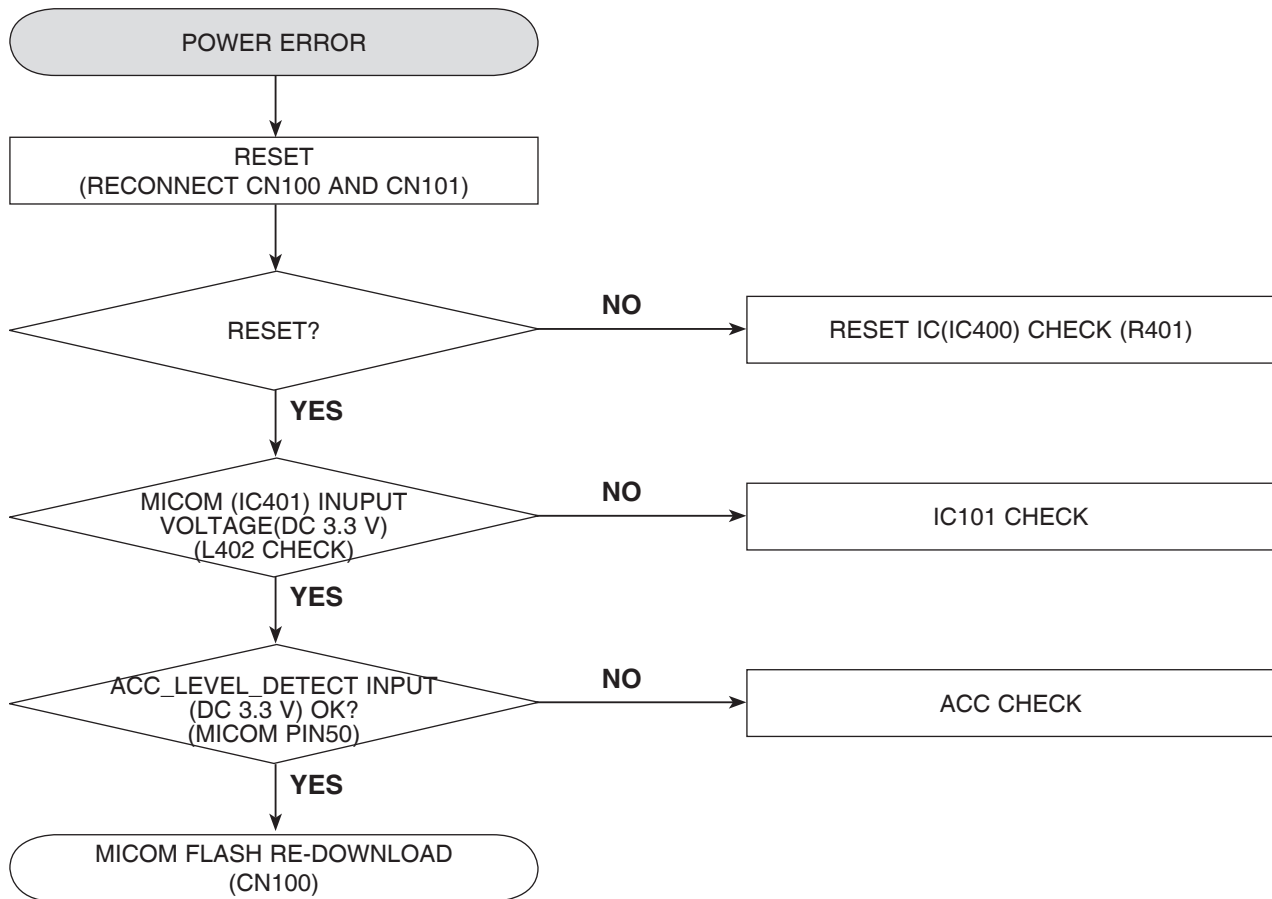

• AUDIO OUTPUT ERROR

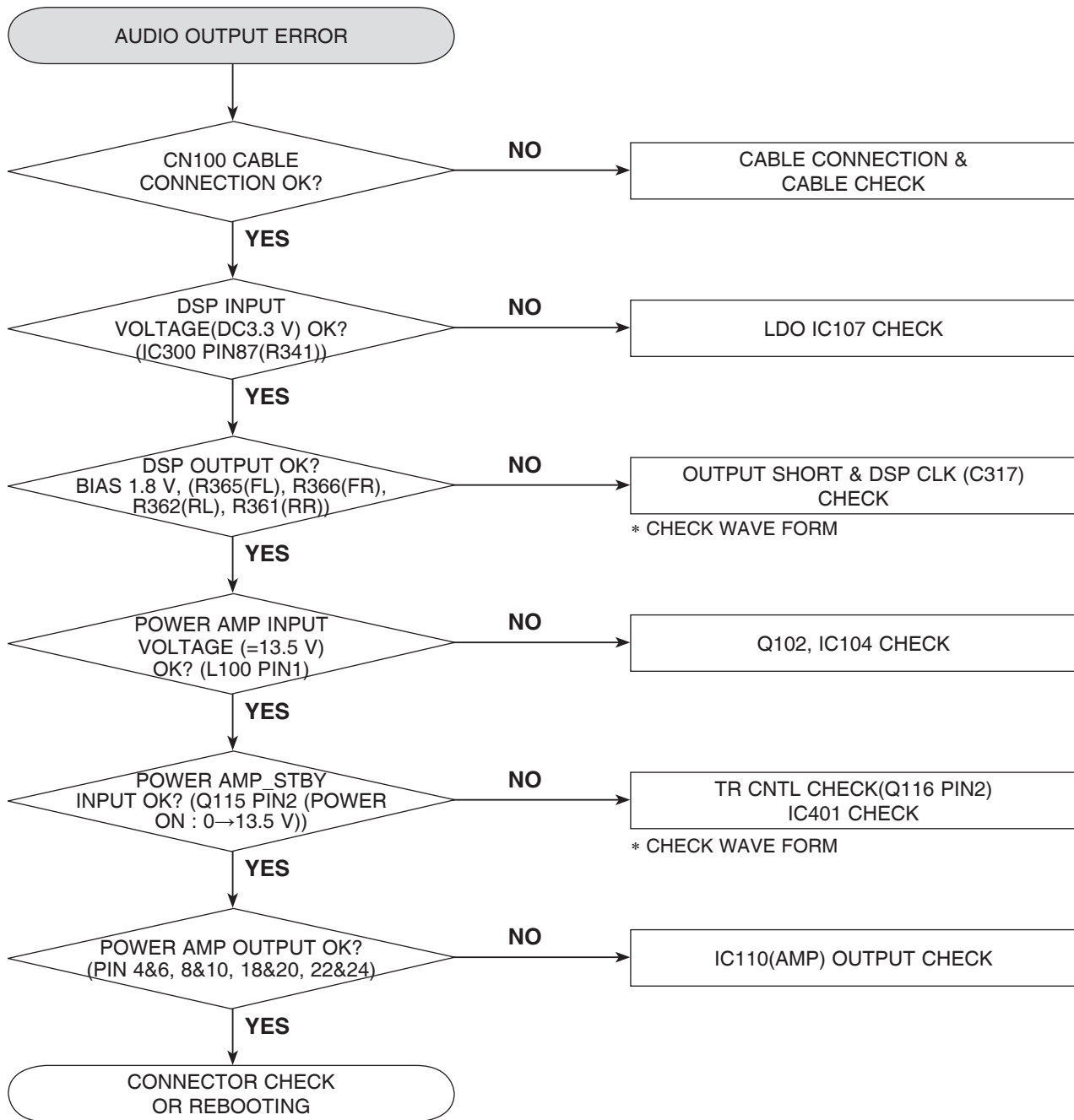

• AUX SOURCE CHECKING

[AUX source input checking]

1. Check front PCB TP2130 (Detect signal)
→ If it is failed, check AUX connector.

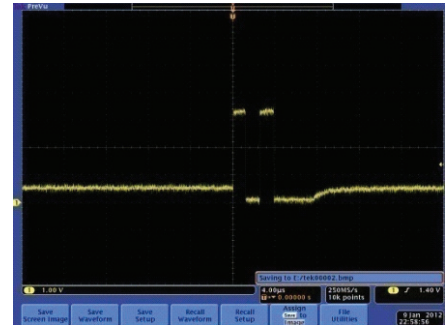
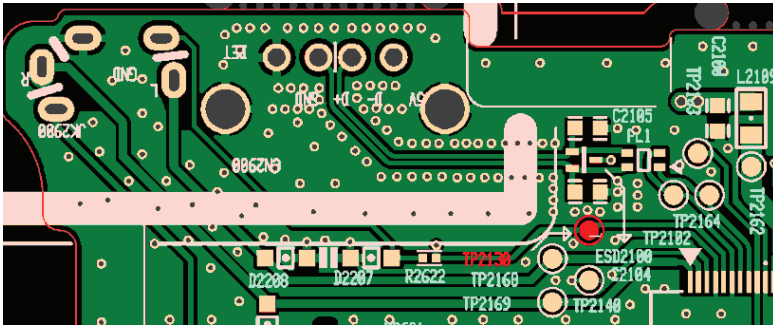

2. Check MAIN PCB. (Detect signal)

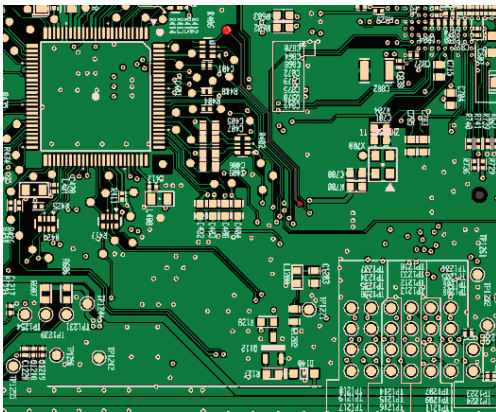

3. Check AUX Left, Right signal. (front : TP2168, TP2169 / MAIN : C319, C324)

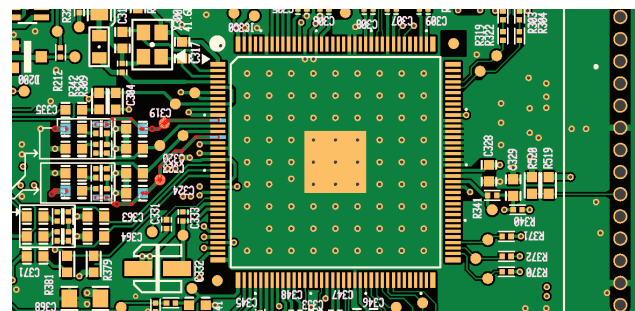
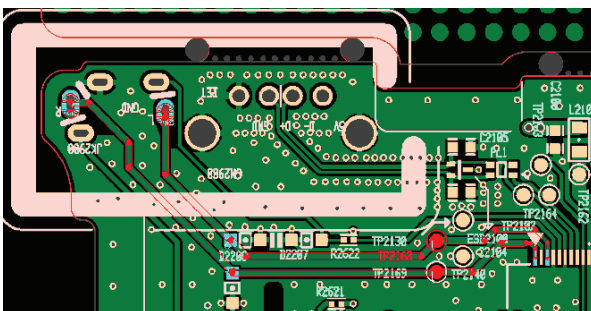

4. If there are different signals between front & MAIN.
→ Check 40pin cable.

• USB, IPOD, BLUETOOTH SOURCE CHECKING

[I2S data signal checking]

1. Check Main PCB R349.
→ If it is not failed, check DSP chip.

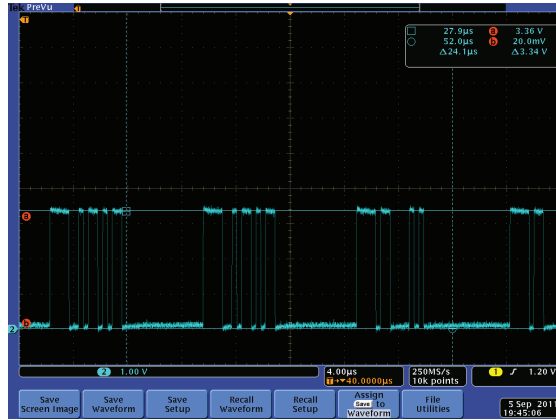
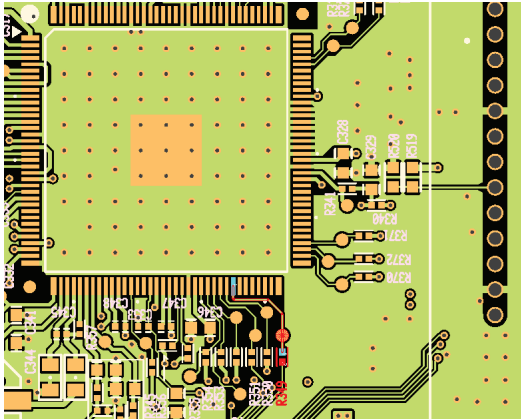

2. If R349 data is failed,
 - a. Bluetooth : check Bluetooth chip (PCM, BT_Rx, BT_Tx), 40pin cable and CPU.
 - b. USB, iPOD : check TP2102, TP2164.
 - If it is OK : check 40pin cable and CPU.
 - If it is failed : check USB connector

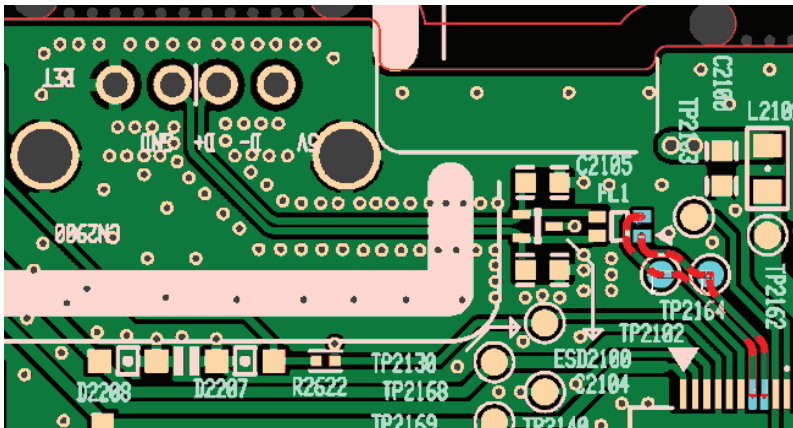

3. POWER PART

• SET BOOTING ERROR

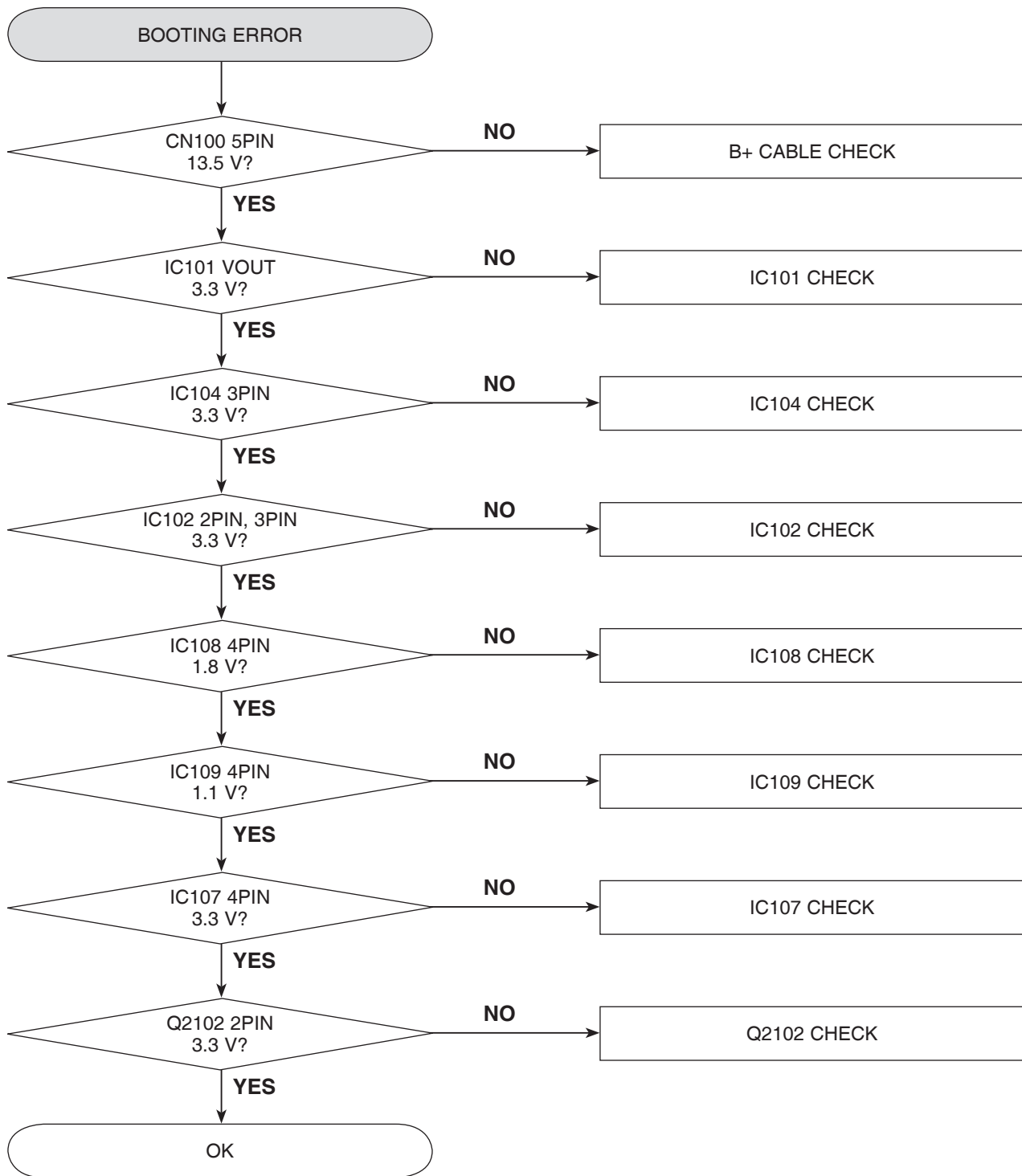

• ACTIVE ANTENNA NG

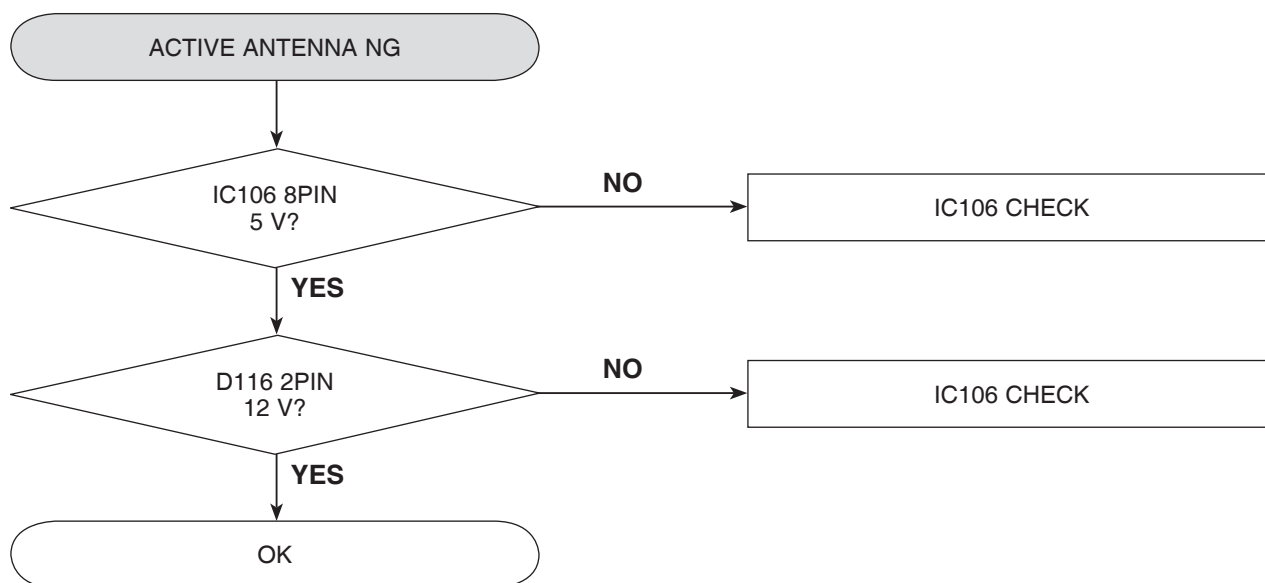

4. GPS PART

• SET BOOTING ERROR

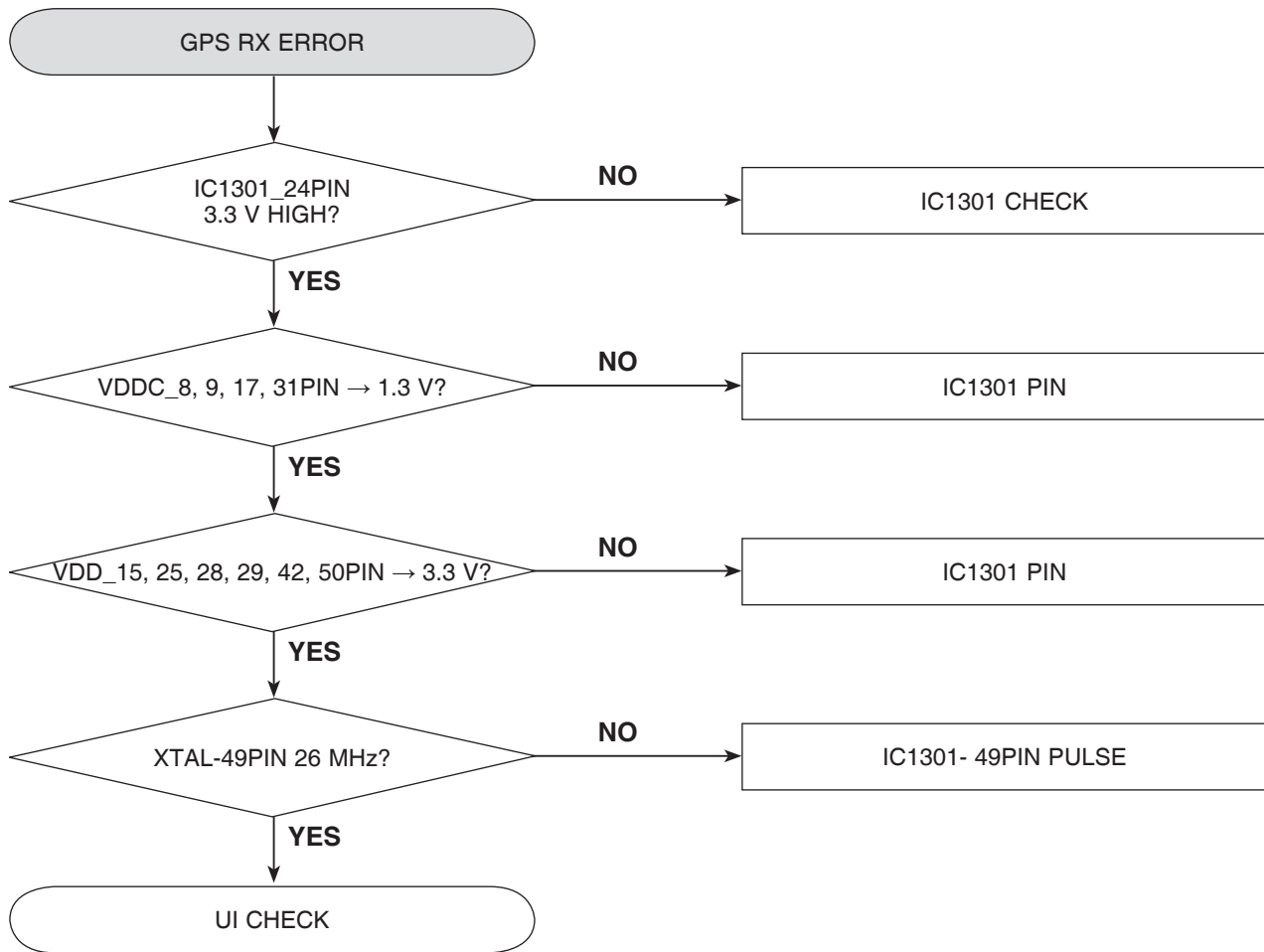

• GPS SATELLITE SIGNAL FIX ERROR

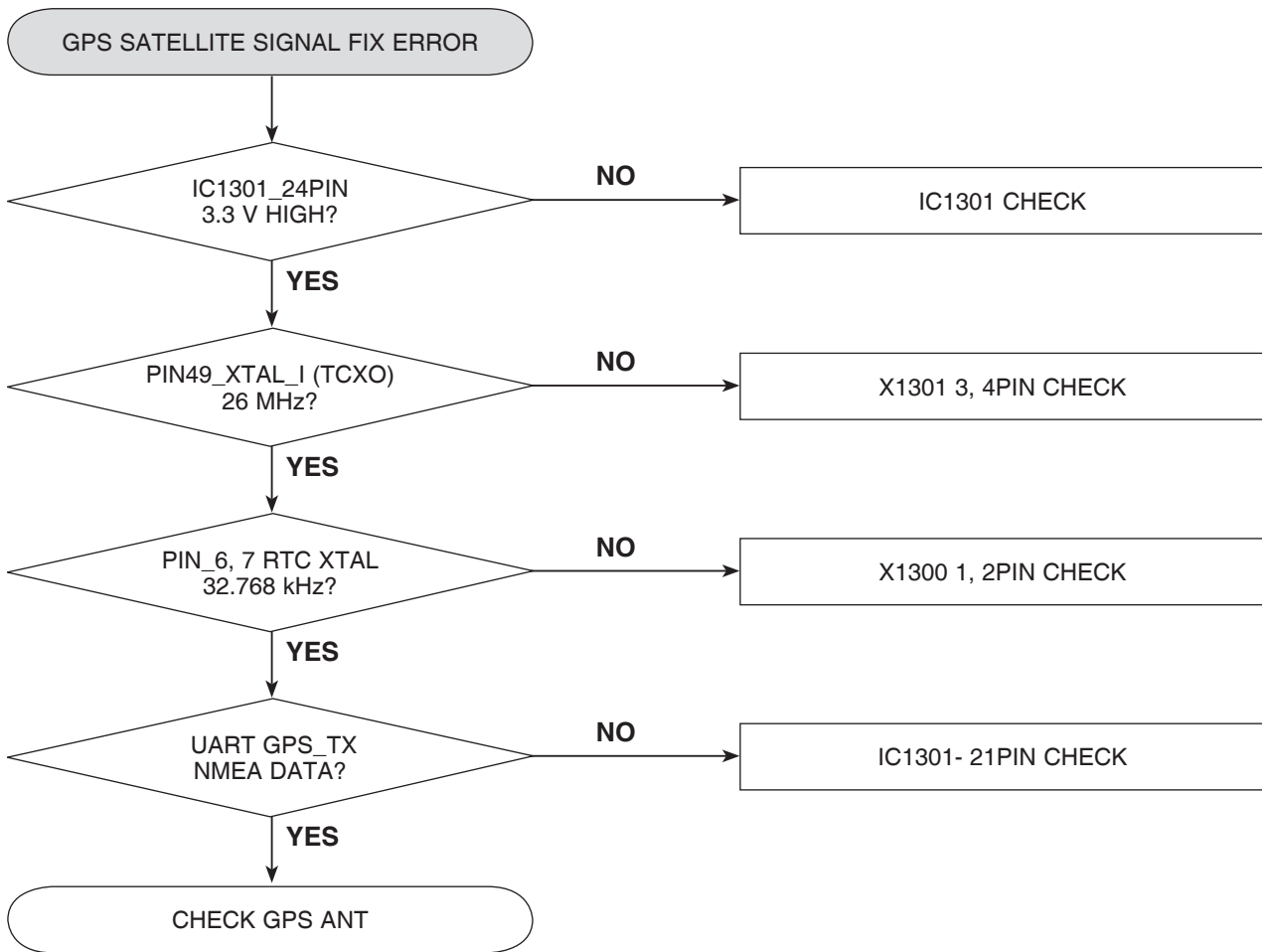

CONNECTOR TERMINAL FUNCTION

1. 24PIN SIGNAL CONNECTOR

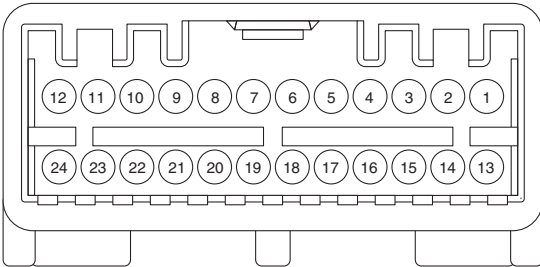

No.	Signal Name	Function
1	ILL	Illumination Signal
2	ACC	Wake-up Signal
3	REAR GEAR	Rear gear engaged
4	N.C	N.C
5	N.C	N.C
6	N.C	N.C
7	MIC_SIG	External microphone signal
8	PWR_MIC	External microphone supply
9	PWR_CAM	Rear camera power supply
10	CAM_IN +	Rear camera video signal +
11	AUX2_IN +	Line in mono +
12	INFO_AUX2_IN	Line in detection Audio switch function
13	SPEED	Vehicle speed
14	IGN	Wake-up signal
15	CAN_H	CAN High Multimedia
16	CAN_L	CAN Low Multimedia
17	N.C	N.C
18	N.C	N.C
19	MIC_GND	External Microphone ground
20	N.C	N.C
21	CAN_GND	Rear camera ground
22	CAM_IN -	Rear camera video signal -
23	AUX2_IN_GND	Line in mono -
24	AUX2_IN_SHIELD	Line in mono shield

2. 12PIN POWER / AUDIO CONNECTOR

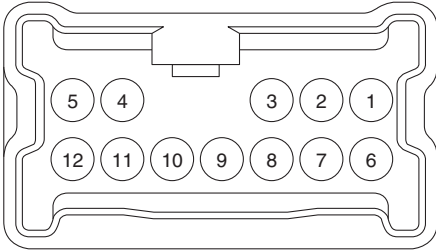

No.	Signal Name	Function
1	HP AR G+	Left rear speaker +
2	HP AV G+	Left front speaker +
3	HP AV D+	Right front speaker +
4	N.C	N.C
5	BAT	Radio Power Supply
6	HP AR G-	Left rear speaker -
7	HP AV G-	Left front speaker -
8	HP AV D-	Right front speaker -
9	HP AR D+	Right Rear speaker +
10	HP AR D-	Right Rear speaker -
11	N.C	N.C
12	GND	Radio ground

3. 8PIN REMOTE CONTROL CONNECTOR

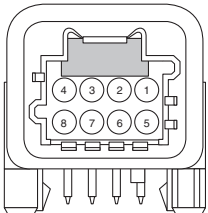

No.	Signal	Name Function
1	IN0	Steering wheel remote controller IN0
2	IN1	Steering wheel remote controller IN1
3	IN2	Steering wheel remote controller IN2
4	L0	Steering wheel remote controller L0
5	L1	Steering wheel remote controller L1
6	L2	Steering wheel remote controller L2
7	N.C	N.C
8	N.C	N.C

MEMO

A series of horizontal dotted lines spanning the width of the page, intended for handwritten notes.

WAVEFORMS

1. FRONT PART

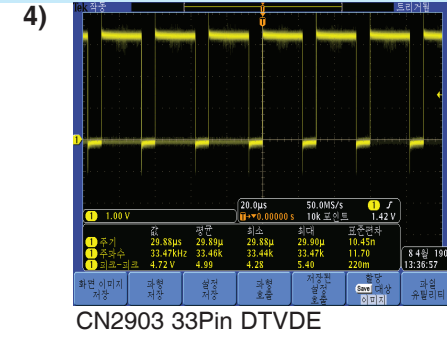
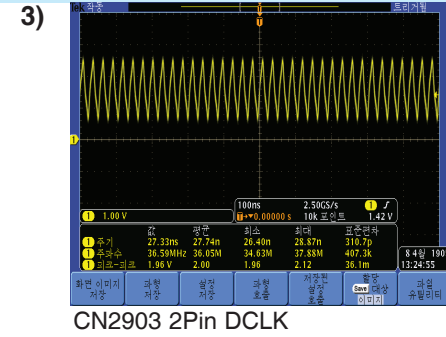
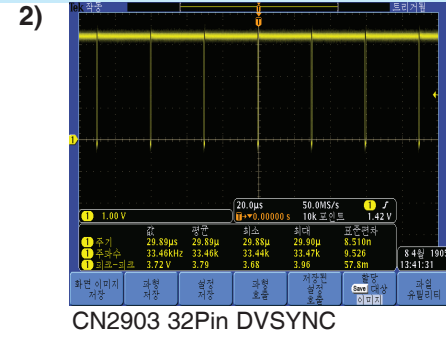
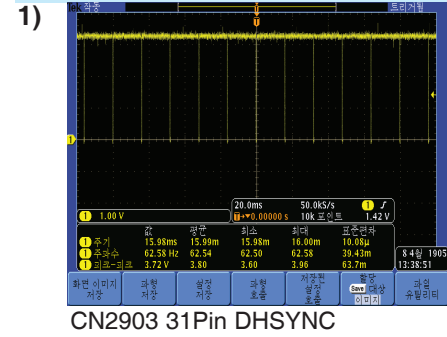

2. AUDIO PART

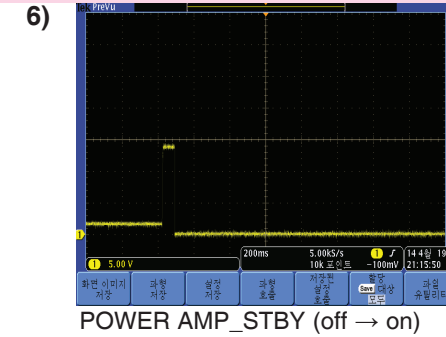
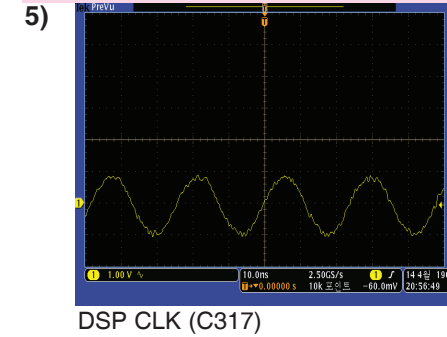

3. MAIN PART

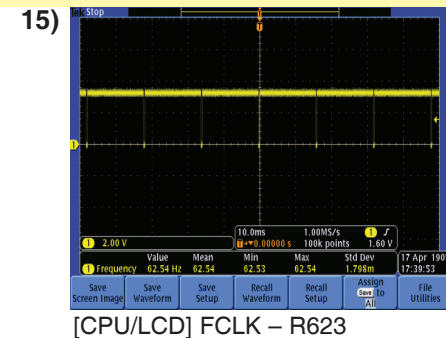
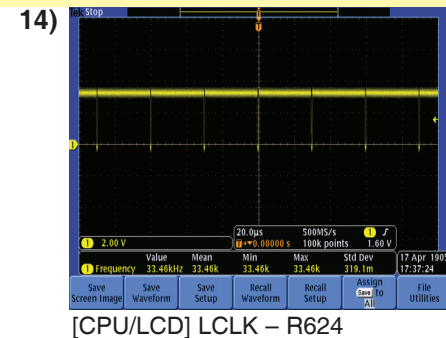
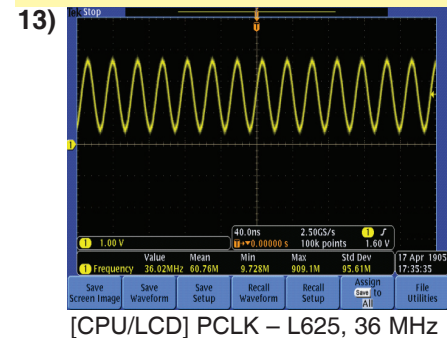
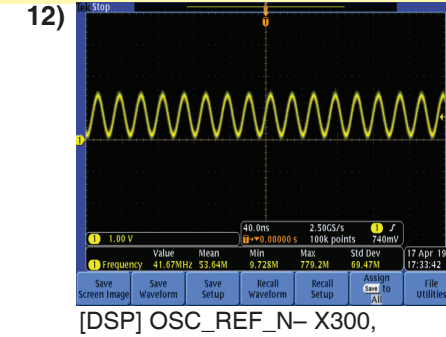
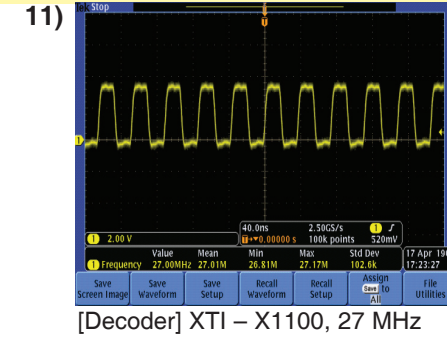
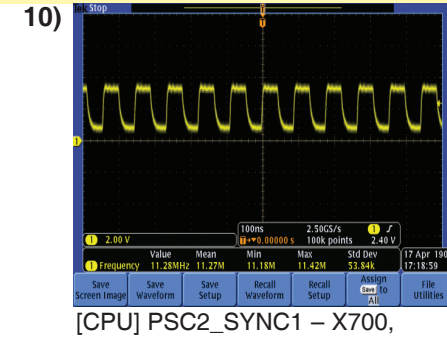
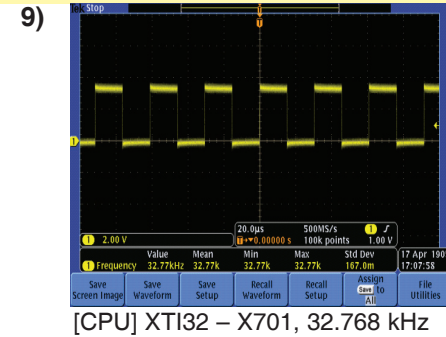
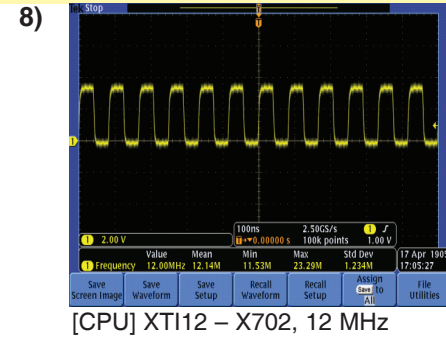
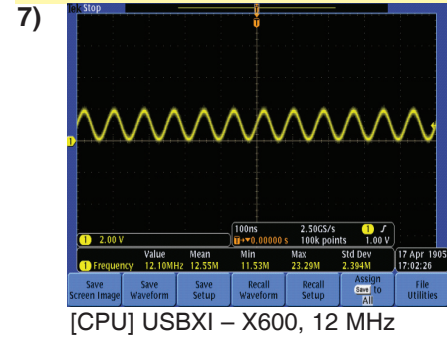

4. GPS PART

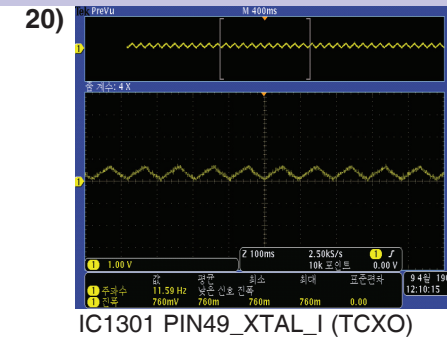
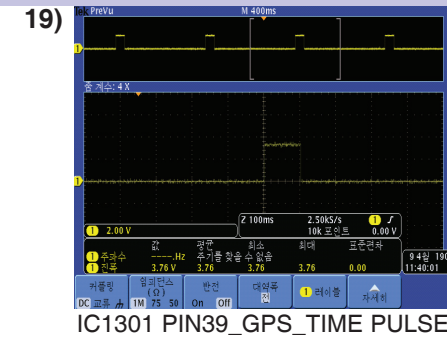
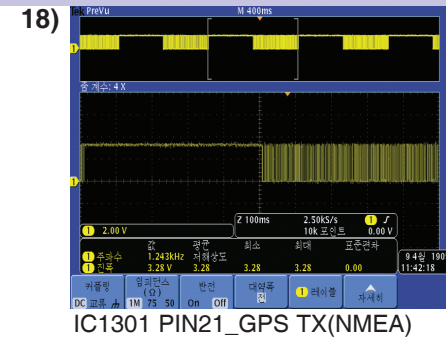
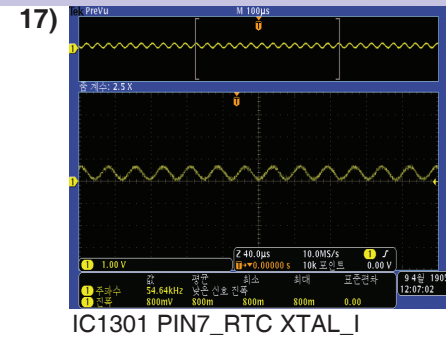
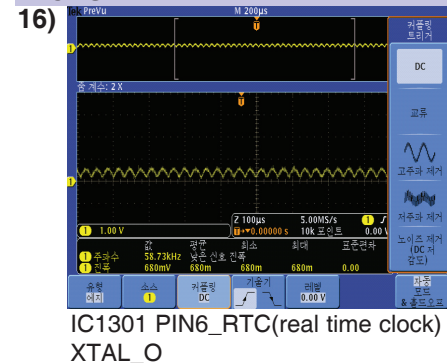

CIRCUIT VOLTAGE CHART

CN2903					
Pin#	Description	Voltage	Pin#	Description	Voltage
1	GND	DGND	26	B4	H/L
2	DCLK	CLK	27	B5	H/L
3	GND	DGND	28	B6	H/L
4	R0	H/L	29	B7	H/L
5	R1	H/L	30	GND	DGND
6	R2	H/L	31	DHSYNC	CLK
7	R3	H/L	32	DVSYNC	CLK
8	R4	H/L	33	DDE	CLK
9	R5	H/L	34	GND	DGND
10	R6	H/L	35	GND	DGND
11	R7	H/L	36	LCD_3.3 V	3.3 V
12	GND	DGND	37	LCD_3.3 V	3.3 V
13	G0	H/L	38	LCD_3.3 V	3.3 V
14	G1	H/L	39	GND	DGND
15	G2	H/L	40	GND	DGND
16	G3	H/L	41	ILL	12.5 V
17	G4	H/L	42	ILL	12.5 V
18	G5	H/L	43	ILL	12.5 V
19	G6	H/L	44	GND	DGND
20	G7	H/L	45	GND	DGND
21	GND	DGND	46	LCD_5V	5 V
22	B0	H/L	47	LCD_5V	5 V
23	B1	H/L	48	LCD_5V	5 V
24	B2	H/L	49	LCD_5V	5 V
25	B3	H/L	50	GND	DGND

CN2904					
Pin#	Description	Voltage	Pin#	Description	Voltage
1	AUX_R	H/L	21	MODEL_DETECT	H/L
2	GND	DGND	22	GND	DGND
3	AUX_L	H/L	23	LCD_PWM	H/L
4	GND	DGND	24	GND	DGND
5	AUX_DETECT	H/L	25	AU_I2C_CLK0	CLK
6	GND	DGND	26	AU_I2C_DATA0	H/L
7	AU_USB_HM	H/L	27	TS_IRQ	H/L
8	AU_USB_HP	H/L	28	BT_RESET	CLK
9	I2C_RESET	H/L	29	BT_RX	H/L
10	GND	DGND	30	BT_TX	H/L
11	USB V	5 V	31	PCM_IN	H/L
12	USB_5 V	5 V	32	GND	DGND
13	USB_5 V	5 V	33	PCM_CLK	CLK
14	GND	DGND	34	GND	DGND
15	FRONT_MIC_GND	DGND	35	PCM_SYNC	CLK
16	FRONT_MIC_SIG	H/L	36	PCM OUT	H/L
17	GND	DGND	37	GND	DGND
18	VOLUME+	H/L	38	BT_3.3 V	3.3 V
19	VOLUME-	H/L	39	BT_3.3 V	3.3 V
20	POWER_ON/OFF	H/L	40	GND	DGND

CN2905					
Pin#	Description	Voltage	Pin#	Description	Voltage
1	NC	NC	26	G2	H/L
2	NC	NC	27	G3	H/L
3	GND	DGND	28	G4	H/L
4	DITHB	CLK	29	G5	H/L
5	VCOM_3.8 V	3.8 V	30	G6	H/L
6	NC	NC	31	G7	H/L
7	RESET	H/L	32	B0	H/L
8	AVDD 10.4 V	10.4 V	33	B1	H/L
9	VGL_-7 V	-7 V	34	B2	H/L
10	VGH_16 V	16 V	35	B3	H/L
11	U/D	3.3 V	36	B4	H/L
12	L/R	3.3 V	37	B5	H/L
13	GND	DGND	38	B6	H/L
14	DCLK	CLK	39	B7	H/L
15	GND	DGND	40	HS	CLK
16	R0	H/L	41	VS	CLK
17	R1	H/L	42	DE	H/L
18	R2	H/L	43	MODE	H/L
19	R3	H/L	44	DVDD_3.3 V	3.3 V
20	R4	H/L	45	VCOM	3.8 V
21	R5	H/L	46	GND	DGND
22	R6	H/L	47	VLED-	
23	R7	H/L	48	VLED-	
24	G0	H/L	49	VLED+	10.2 V
25	G1	H/L	50	VLED+	10.2 V

IC100 (MAX9938FELT+T) EUSY0178502		
Symbol	Pin#	Connection
OUT	1	ANALOG
NC	2	-
GND	3	DGND
RS+	4	5 V
NC	5	-
RS-	6	5 V

IC101 (NCV8664DT33RKG) EAN62399801		
Symbol	Pin#	Connection
VIN	1	BAT+
GND	2	DGND
VOUT	3	3.3 V

IC104 (VN5E010MHTR-E) EAN62326701		
Symbol	Pin#	Connection
OUT	1	VCC
GND	2	DGND
IN	3	3.3 V
VCC	4	BAT+
CS	5	ANALOG
CS_DIS	6	H/L
OUT	7	VCC

IC106 (SC4501MLTRT) EAN57246801		
Symbol	Pin#	Connection
COMP	1	ANALOG
FB	2	ANALOG
/SHDN	3	3.3 V
GND	4	DGND
GND	5	DGND
SW	6	ANALOG
SW	7	ANALOG
IN	8	5 V
ROSC	9	ANALOG
SS	10	DGND

IC107 (BD7820FP) EAN62046601		
Symbol	Pin#	Connection
CTL	1	3.3 V
VCC	2	5.0 V
GND	3	DGND
VOUT	4	3.3 V
ADJ	5	0.73

IC108 (NCV5661DTADJRKG) EAN36976602		
Symbol	Pin#	Connection
ENABLE	1	3.3 V
VIN	2	3.3 V
GND	3	DGND
VOUT	4	1.8 V
ADJ	5	0.87 V

IC109 (NCV5661DTADJRKG) EAN36976602		
Symbol	Pin#	Connection
ENABLE	1	3.3 V
VIN	2	3.3 V
GND	3	DGND
VOUT	4	1.1 V
ADJ	5	0.88 V

IC111 (MAX16910CATA9/V+) EAN62213801		
Symbol	Pin#	Connection
IN	1	12 V
ENABLE	2	3.3 V
SET	3	12 V
/RESET	4	H/L
TIMEOUT	5	H/L
SETOV	6	1.25 V
GND	7	CGND
OUT	8	6 V

IC112 (AAT4610BIJS-1-T1) EAN62169401		
Symbol	Pin#	Connection
SET	1	DGND
/ON	2	3.3 V
IN	3	5.0 V
IN	4	5.0 V
OUT	5	5.0 V
GND	6	DGND
GND	7	DGND
GND	8	DGND

IC400 (BD5229G) EAN62046501		
Symbol	Pin#	Connection
VOUT	1	H/L
VDD	2	3.3 V
GND	3	DGND
NC	4	-
CT	5	DGND

IC402 (NLAS4717MR2G) 0IPRP00746A		
Symbol	Pin#	Connection
VCC	1	3.3 V
NO1	2	ANALOG
COM1	3	ANALOG
IN1	4	H/L
NC1	5	ANALOG
GND	6	DGND
NC2	7	ANALOG
IN2	8	H/L
COM2	9	ANALOG
NO2	10	ANALOG

IC404 (TJA1051T/3) 0IPRP00025C		
Symbol	Pin#	Connection
TXD	1	H/L
GND	2	DGND
VCC	3	5.0 V
RXD	4	H/L
VIO	5	3.3 V
CANL	6	H/L
CANH	7	H/L
S	8	H/L

IC800 (TC1270ARVCTR) EAN54854501		
Symbol	Pin#	Connection
VSS	1	DGND
/RST	2	H/L
/MR	3	H/L
VDD	4	3.3 V

IC802 (341S2313) EAN42565607		
Symbol	Pin#	Connection
P4, /IRQ	1	3.3 V
NC	2	-
/RES	3	H/L
VCC	4	3.3 V
VSS	5	DGND
P2, /IRQ	6	CLK
P1, /IRQ	7	H/L
P3, /IRQ	8	3.3 V

IC1100 (XC6221B182NR) EAN38670901		
Symbol	Pin#	Connection
CE	1	H/L
VSS	2	DGND
VOUT	3	1.8 V
VIN	4	3.3 V

IC1102 (NCV2903DR2G) 0ISTL00114A		
Symbol	Pin#	Connection
OUTPUT A	1	DGND
INPUT A-	2	DGND
INPUT A+	3	DGND
GND	4	DGND
INPUT B+	5	H/L
INPUT B-	6	H/L
OUTPUT B	7	H/L
VCC	8	5.0 V

IC1201 (LM20BIM7) 0IPRPNS034A		
Symbol	Pin#	Connection
NC	1	-
GND	2	DGND
VO	3	ANALOG
V+	4	3.3 V
GND	5	DGND

IC2603 (MAX11803ETC+T) EAN62207901		
Symbol	Pin#	Connection
X+	1	ANALOG
VDD	2	3.3 V
GND	3	DGND
X-	4	ANALOG
Y-	5	ANALOG
/TIRQ	6	H/L
SDA	7	DATA
SCL	8	CLK
A0	9	DGND
A1	10	DGND
AUX	11	-
Y+	12	ANALOG

IC102 (MAX15023ETG+T) EAN36285004					
Symbol	Pin#	Connection	Symbol	Pin#	Connection
FB1	1	0.6 V	PGND2	13	DGND
EN1	2	3.3 V	DL2	14	H/L
EN2	3	3.3 V	PGOOD2	15	-
PGOOD1	4	-	VCC	16	5.2 V
DL1	5	H/L	FB2	17	0.6 V
PGND1	6	DGND	COMP2	18	H/L
LX1	7	5.0 V	RT	19	H/L
BST1	8	H/L	SGND	20	DGND
DH1	9	H/L	IN	21	VCC
DH2	10	H/L	LIM2	22	H/L
BST2	11	H/L	LIM1	23	H/L
LX2	12	3.3 V	COMP1	24	H/L

IC110 (TDF8546) EAN62086801					
Symbol	Pin#	Connection	Symbol	Pin#	Connection
ADSE1	1	DGND	IN4	15	AUDIO(RR)
STB	2	H/L	IN3	16	AUDIO(RF)
PGND2	3	DGND	AC-GND	17	DGND
OUT2-	4	AUDIO(LF-)	OUT3+	18	AUDIO(RF+)
DIAG	5	-	PGND3	19	DGND
OUT2+	6	AUDIO(LF+)	OUT3-	20	AUDIO(RF-)
VP2	7	VCC	VP1	21	VCC
OUT1-	8	AUDIO(LR-)	OUT4+	22	AUDIO(RR+)
PGND1	9	DGND	SCL	23	CLK
OUT1+	10	AUDIO(LR+)	OUT4-	24	AUDIO(RR-)
SVR	11	DGND	PGND4	25	DGND
IN1	12	AUDIO(LR)	SDA	26	H/L
IN2	13	AUDIO(LF)	TAB	27	DGND
SGND	14	DGND			

IC1004 (SN74LVTH574PWR) 0ISTLT1007A					
Symbol	Pin#	Connection	Symbol	Pin#	Connection
/OE	1	DGND	CLK	11	CLK
1D	2	H/L	8Q	12	DGND
2D	3	H/L	7Q	13	H/L
3D	4	H/L	6Q	14	H/L
4D	5	H/L	5Q	15	H/L
5D	6	H/L	4Q	16	H/L
6D	7	H/L	3Q	17	H/L
7D	8	H/L	2Q	18	H/L
8D	9	DGND	1Q	19	H/L
GND	10	DGND	VCC	20	3.3 V

IC200 (TEF7000HN/V2) EAN60765801					
Symbol	Pin#	Connection	Symbol	Pin#	Connection
SWPORT1	1	-	IC	25	-
WXRFIN1	2	-	ADDRESS	26	DGND
WXRFIN2	3	-	SWPORT2	27	-
FMRFIN1	4	ANALOG	DICE_CLKN	28	CLK
FMRFIN2	5	ANALOG	DICE_CLKP	29	CLK
IC	6	H/L	GNDDIG	30	DGND
VCCRF	7	5.0 V	SDA	31	H/L
GNDRF	8	DGND	SCL	32	CLK
AMLNAIN1	9	ANALOG	LDI_REQ_IN	33	H/L
AMLNAIN2	10	DGND	LDI_CMD_OUT	34	H/L
AMAGCSW	11	DGND	HOLD	35	H/L
IC	12	-	SAMPLE	36	H/L
AMLNAOUT1	13	ANALOG	VREF	37	DGND
AMLNAOUT2	14	ANALOG	VCC2V8DEC	38	DGND
IC	15	-	VCC5V	39	5.0 V
AMMIXIN2	16	ANALOG	GND	40	DGND
AMMIXIN1	17	ANALOG	CPOUT2	41	ANALOG
GNDIF	18	DGND	CPOUT1	42	ANALOG
TST1	19	-	VTUNE	43	ANALOG
TST2	20	-	VCCVCODEC	44	ANALOG
IFOUTQ_N	21	ANALOG	GNDVCO	45	DGND
IFOUTQ_P	22	ANALOG	IC	46	-
IFOUTI_N	23	ANALOG	FMANTBUF2	47	-
IFOUTI_P	24	ANALOG	FMANTBUF1	48	-

IC1101 (TW9900-NA1-GR) EAN62215701					
Symbol	Pin#	Connection	Symbol	Pin#	Connection
AVD	1	1.8 V	VD4	17	H/L
MUX1	2	H/L	VDD33	18	3.3 V
MUX0	3	-	VD3	19	H/L
YGND	4	DGND	VD2	20	H/L
AVS	5	DGND	VD1	21	H/L
CIN0	6	DGND	VD0/SIAD	22	H/L
AVDPLL	7	1.8 V	VDD	23	1.8 V
AVSPLL	8	DGND	VSSPST	24	DGND
VSYNC	9	-	XTI	25	CLK (27 MHz)
HSYNC	10	-	XTO	26	-
MPOUT	11	-	VDD33	27	3.3 V
CLKX2	12	CLK	SCLK	28	CLK
VSS	13	DGND	SDAT	29	H/L
VD7	14	H/L	PDN	30	DGND
VD6	15	H/L	RSTB	31	H/L
VD5	16	H/L	INTREQ	32	H/L

IC1400 (LBMA-2C66C2-SA) EAT61553201					
Symbol	Pin#	Connection	Symbol	Pin#	Connection
ANT	1	ANALOG	NC	17	-
GND	2	DGND	PCM_CLK	18	CLK
PIO(0)	3	-	PCM_IN	19	H/L
PIO(1)	4	-	UART_RTS	20	-
AIO(0)	5	-	UART_TX	21	H/L
VDD_VREGIN	6	3.3 V	UART_CTS	22	-
PIO(4)	7	-	UART_RX	23	H/L
PIO(5)	8	-	RESETB	24	H/L
GND	9	DGND	GND	25	DGND
PIO(8)	10	-	SPI_CSB	26	-
USB_DP	11	-	SPI_CLK	27	-
USB_DN	12	-	SPI_MISO	28	-
VDD_1R8V	13	DGND	SPI_MOSI	29	-
PCM_OUT	14	H/L	PIO(3)	30	-
PCM_SYNC	15	H/L	PIO(2)	31	-
GND	16	DGND	GND	32	DGND

IC2602 (AAT2823IBK-T1) EAN61125901					
Symbol	Pin#	Connection	Symbol	Pin#	Connection
WLX	1	5 V	COMP	13	DGND
PGND2	2	DGND	FB	14	0.6 V
REF	3	0 V	N.C	15	-
FBN	4	0 V	N.C	16	-
WEN	5	5 V	N.C	17	-
DRVN	6	H/L	N.C	18	-
VDD	7	10.4 V	WCOMP	19	DGND
DRVP	8	H/L	WFB	20	H/L
EN	9	5 V	OVP	21	10.2 V
FBP	10	0.6 V	VIN	22	5 V
PGND1	11	DGND	AGND	23	DGND
LX	12	5 V	WDIM	24	5 V

IC1003 (MX29LV320ETTI-70G) 0IMMRMR027G																	
Symbol	Pin#	Connection	Symbol	Pin#	Connection	Symbol	Pin#	Connection	Symbol	Pin#	Connection	Symbol	Pin#	Connection	Symbol	Pin#	Connection
A15	1	H/L	A12	9	H/L	A17	17	H/L	A0	25	H/L	Q2	33	H/L	Q13	41	H/L
A13	2	H/L	A14	10	H/L	A7	18	H/L	/CE	26	H/L	Q10	34	H/L	Q6	42	H/L
A8	3	H/L	/WE	11	H/L	A6	19	H/L	GND	27	DGND	Q3	35	H/L	Q14	43	H/L
A10	4	H/L	/RESET	12	H/L	A5	20	H/L	/OE	28	H/L	Q11	36	H/L	Q7	44	H/L
A9	5	H/L	NC	13	-	A4	21	H/L	Q0	29	H/L	VCC	37	3.3 V	Q15/A-1	45	H/L
A11	6	H/L	/WP/ACC	14	3.3 V	A3	22	H/L	Q8	30	H/L	Q4	38	H/L	GND	46	DGND
A19	7	H/L	RY//BY	15	-	A2	23	H/L	Q1	31	H/L	Q12	39	H/L	/BYTE	47	3.3 V
A20	8	H/L	A18	16	H/L	A1	24	H/L	Q9	32	H/L	Q5	40	H/L	A16	48	H/L

IC1300 (UBX-G6010-ST) EAN62215901																	
Symbol	Pin#	Connection	Symbol	Pin#	Connection	Symbol	Pin#	Connection	Symbol	Pin#	Connection	Symbol	Pin#	Connection	Symbol	Pin#	Connection
IBIAS	1	DGND	PIO22	11	-	PIO5	21	H/L	VDD_C1	31	1.3 V	PIO13	41	-	VDD_RF	51	DGND
LNAOUT	2	ANALOG	VDD_USB	12	DGND	V_TH	22	DGND	PIO19	32	-	VDD_IO1	42	3.3 V	VDD_SYNTH	52	DGND
VDCTEST	3	DGND	USB_DP	13	-	V_RESET	23	H/L	PIO2	33	-	CFG_PIN	43	-	LDO2_OUT	53	DGND
MIX_IN_P	4	ANALOG	USB_DM	14	-	PIO4	24	H/L	PIO3	34	-	PIO7	44	H/L	VDD_ANA	54	DGND
MIX_IN_N	5	ANALOG	VDD_IO0	15	3.3 V	V_DCDC	25	3.3 V	PIO14	35	-	PIO8	45	-	VDD_LNA	55	DGND
RTC_XTAL_I	6	CLK(32.768 kHz)	PIO18	16	-	DCDC_EN	26	-	PIO15	36	-	N.C	46	-	LNAIN	56	ANALOG
RTC_XTAL_O	7	CLK(32.768 kHz)	VDD_C0	17	1.3 V	N.C	27	-	PIO17	37	-	TCXO_POWER	47	ANALOG			
VSS_PLL	8	1.3 V	PIO20	18	-	V_BCKP	28	3.3 V	SAFEBOOT_N	38	H/L	XTAL_O	48	-			
VDD_PLL	9	1.3 V	PIO21	19	-	V_RUN	29	3.3 V	TIMEPULSE	39	H/L	XTAL_I	49	CLK(26 MHz)			
PIO23	10	-	PIO6	20	-	VDD_B	30	DGND	TCK	40	-	VDD_3V	50	3.3 V			

IC401 (uPD78F1845GCA-UEU-G) EAN62233701														
Symbol	Pin#	Connection	Symbol	Pin#	Connection	Symbol	Pin#	Connection	Symbol	Pin#	Connection	Symbol	Pin#	Connection
P153	1	H/L	EVSS0	21	DGND	P75	41	H/L	LTxD0	61	H/L	ANI06	81	ANALOG
P152	2	H/L	VDD	22	3.3 V	P74	42	H/L	P12	62	-	ANI07	82	ANALOG
P151	3	-	EVDD0	23	3.3 V	EVSS1	43	DGND	P11	63	H/L	ANI08	83	ANALOG
P150	4	H/L	SCL11	24	CLK	CRxD	44	H/L	P10	64	H/L	P91	84	-
P47	5	-	SDA11	25	H/L	CTxD	45	H/L	P54	65	H/L	ANI10	85	ANALOG
P46	6	H/L	P62(Nch-OD)	26	H/L	P71	46	H/L	P55	66	H/L	ANI11	86	ANALOG
P45	7	H/L	P63(Nch-OD)	27	DGND	P70	47	H/L	P56	67	-	ANI12	87	ANALOG
P44	8	-	P64	28	H/L	P03	48	H/L	TI17	68	H/L	ANI13	88	ANALOG
RxD2	9	H/L	P65	29	H/L	P32	49	H/L	P107	69	-	P96	89	H/L
TxD2	10	H/L	P66	30	H/L	P30	50	H/L	P106	70	-	P97	90	H/L
TOOL1	11	CLK	P67	31	H/L	P17	51	H/L	P105	71	H/L	P100	91	H/L
TOOL0	12	H/L	P154	32	H/L	P16	52	H/L	P104	72	H/L	P101	92	H/L
RESET	13	H/L	P155	33	H/L	EVDD1	53	3.3 V	AVREF	73	DGND	P102	93	H/L
P124	14	DGND	P00	34	-	P15	54	H/L	AVSS	74	DGND	P103	94	H/L
P123	15	-	P156	35	-	P31	55	H/L	P80	75	-	P02	95	-
FLMD0	16	H/L	P157	36	-	P50	56	H/L	ANI01	76	ANALOG	P127	96	H/L
P122	17	CLK	P140	37	-	P51	57	H/L	ANI02	77	ANALOG	P126	97	H/L
P121	18	CLK	P130	38	-	TO22	58	CLK	ANI03	78	ANALOG	P01	98	H/L
REGC	19	DGND	P77	39	H/L	TI23	59	H/L	ANI04	79	ANALOG	P125	99	H/L
VSS	20	DGND	P76	40	H/L	LRxD0	60	H/L	ANI05	80	ANALOG	P120	100	H/L

IC300 (SAF7741HV_N125) EAN60763802														
Symbol	Pin#	Connection	Symbol	Pin#	Connection	Symbol	Pin#	Connection	Symbol	Pin#	Connection	Symbol	Pin#	Connection
OSC_REF_N	1	VSS	VDD_REG	31	3.3 V	WS_IN2	61	H/L	T1E_WS	91	DGND	VSSS4	121	VSS
OSC_IN	2	ANALOG	FEBREG	32	1.8 V	SD_IN2	62	H/L	T1E_SD_OUT	92	DGND	TDO	122	-
OSC_OUT	3	ANALOG	CONREG	33	ANALOG	BCK_IN3	63	CLK	T1E_SD_IN	93	DGND	TCK	123	DGND
OSC_REF_P	4	1.8 V	GAPREG	34	ANALOG	WS_IN3	64	H/L	DR_BCK_OUT	94	DGND	TRSTN	124	DGND
AIN0_R	5	ANALOG	VDDQ1	35	3.3 V	SD_IN3	65	H/L	DR_WS_OUT	95	DGND	IFADI_P1	125	-
AIN0_R_REF	6	DGND	VSSQ1	36	DGND	BCK_IN4	66	-	DR_SD_OUT_I	96	DGND	IFADI_N1	126	-
AIN0_L_REF	7	DGND	DAC_RR	37	ANALOG	WS_IN4	67	-	DR_SD_OUT_Q	97	DGND	IFADQ_P1	127	-
AIN0_L	8	ANALOG	DAC_RL	38	ANALOG	SD_IN4	68	-	VSSS3_DC	98	VSS	IFADQ_N1	128	-
AIN1_R	9	DGND	VDACN	39	DGND	SD_HOST_IN1	69	-	VDDD3	99	1.8 V	VDD_IFAD	129	3.3 V
AIN1_L	10	DGND	VDACP	40	3.3 V	SD_HOST_IN2	70	-	TDSP_IOF1	100	-	VIFADN	130	DGND
AIN2_R	11	ANALOG	VDD_DAC	41	3.3 V	SD_HOST_IN3	71	-	TDSP_IOF2	101	-	VIFADP	131	DGND
AIN2_R_REF	12	DGND	DAC_FR	42	ANALOG	SD_HOST_IN4	72	-	TDSP_IOF3	102	-	VSS_IFAD	132	DGND
AIN2_L_REF	13	DGND	DAC_FL	43	ANALOG	SD_HOST_IN5	73	-	TDSP_IOF4	103	-	VIFADBG	133	DGND
AIN2_L	14	ANALOG	DAC_SUBW	44	ANALOG	WS_HOST	74	H/L	TDSP_IOF5	104	H/L	VDDA_1V8	134	1.8 V
VDDA_1V8_ADC	15	1.8 V	DAC_CENTER	45	ANALOG	BCK_HOST	75	CLK	TDSP_IOF6	105	H/L	IFADI_P2	135	ANALOG
VADCN	16	DGND	VSSS2	46	VSS	SD_HOST_OUT1	76	H/L	TDSP_IOF7	106	-	IFADI_N2	136	ANALOG
VADCP	17	3.3 V	VDDD2	47	1.8 V	SD_HOST_OUT2	77	-	TDSP_IOF8	107	-	IFADQ_P2	137	ANALOG
VREFAD	18	DGND	RDS_CLK1	48	-	SD_HOST_OUT3	78	-	TDSP_IOF9	108	-	IFADQ_N2	138	ANALOG
AIN3	19	ANALOG	RDS_DATA1	49	H/L	SD_HOST_OUT4	79	-	TDSP_IOF10	109	-	TMS	139	DGND
AIN3_REF	20	DGND	RDS_CLK2	50	-	ADSP_IOF4	80	-	VDD_MEM2	110	1.8 V	RGPDAC1	140	-
AIN4	21	ANALOG	RDS_DATA2	51	-	ADSP_IOF5	81	-	VSS_MEM2	111	VSS	RGPDAC2	141	-
AIN4_REF	22	DGND	RESETN	52	H/L	ADSP_IOF6	82	-	AGC1_1	112	-	TDI	142	DGND
VDD_ADC	23	3.3 V	FS_SYS	53	-	ADSP_IOF7	83	-	AGC1_2	113	-	DICE_CLKP	143	CLK
SPDIF_IN1	24	ANALOG	VSS_MEM1	54	VSS	ADSP_IOF8	84	-	AGC2_1	114	ANALOG	DICE_CLKN	144	CLK
SPDIF_IN2	25	ANALOG	VDD_MEM1	55	1.8 V	ADSP_IOF9	85	-	AGC2_2	115	ANALOG			
VDDD1	26	1.8 V	SCL	56	CLK	ADSP_IOF10	86	H/L	VDDQ4	116	3.3 V			
VSSS1	27	VSS	SDA	57	H/L	ADSP_IOF11	87	H/L	VSSQ4	117	VSS			
BCK_IN1	28	-	VSSQ2	58	VSS	VSSQ3	88	VSS	SCL_DICE	118	CLK			
WS_IN1	29	-	VDDQ2	59	3.3 V	VDDQ3	89	3.3 V	SDA_DICE	119	H/L			
SD_IN1	30	-	BCK_IN2	60	CLK	T1E_BCK	90	DGND	VDDD4	120	1.8 V			

IC900 (V59C1G01168QBJ25AI) - 64Mx16 DDR2 EAN61830801 (TOP VIEW: see balls through package)						
	1	2	3	7	8	9
A	VDD	NC	VSS	VSSQ	/UDQS	VDDQ
	1.8 V	-	DGND	DGND	H/L	1.8 V
B	DQ14	VSSQ	UDM	UDQS	VSSQ	DQ15
	H/L	DGND	H/L	H/L	H/L	H/L
C	VDDQ	DQ9	VDDQ	VDDQ	DQ8	VDDQ
	1.8 V	H/L	1.8 V	1.8 V	H/L	1.8 V
D	DQ12	VSSQ	DQ11	DQ10	VSSQ	DQ13
	H/L	DGND	H/L	H/L	DGND	H/L
E	VDD	NC	VSS	VSSQ	/LDQS	VDDQ
	1.8 V	-	DGND	DGND	H/L	1.8 V
F	DQ6	VSSQ	LDM	LDQS	VSSQ	DQ7
	H/L	DGND	H/L	H/L	DGND	H/L
G	VDDQ	DQ1	VDDQ	VDDQ	DQ0	VDDQ
	1.8 V	H/L	1.8 V	1.8 V	H/L	1.8 V
H	DQ4	VSSQ	DQ3	DQ2	VSSQ	DQ5
	H/L	DGND	H/L	H/L	DGND	H/L
J	VDDL	VREF	VSS	VSSDL	CK	VDD
	1.8 V	0.9 V	DGND	1.8 V	H/L	1.8 V
K		CKE	/WE	/RAS	/CK	ODT
		H/L	H/L	H/L	H/L	1.8 V
L	BA2	BA0	BA1	/CAS	/CS	
	H/L	H/L	H/L	H/L	H/L	
M		A10/AP	A1	A2	A0	VDD
		H/L	H/L	H/L	H/L	1.8 V
N	VSS	A3	A5	A6	A4	
	DGND	H/L	H/L	H/L	H/L	
P		A7	A9	A11	A8	VSS
		H/L	H/L	H/L	H/L	DGND
R	VDD	A12	RFU	RFU	RFU	
	1.8 V	H/L	DGND	DGND	H/L	

IC901 (V59C1G01168QBJ25AI) - 64Mx16 DDR2 EAN61830801 (TOP VIEW: see balls through package)						
	1	2	3	7	8	9
A	VDD	NC	VSS	VSSQ	/UDQS	VDDQ
	1.8 V	-	DGND	DGND	H/L	1.8 V
B	DQ14	VSSQ	UDM	UDQS	VSSQ	DQ15
	H/L	DGND	H/L	H/L	H/L	H/L
C	VDDQ	DQ9	VDDQ	VDDQ	DQ8	VDDQ
	1.8 V	H/L	1.8 V	1.8 V	H/L	1.8 V
D	DQ12	VSSQ	DQ11	DQ10	VSSQ	DQ13
	H/L	DGND	H/L	H/L	DGND	H/L
E	VDD	NC	VSS	VSSQ	/LDQS	VDDQ
	1.8 V	-	DGND	DGND	H/L	1.8 V
F	DQ6	VSSQ	LDM	LDQS	VSSQ	DQ7
	H/L	DGND	H/L	H/L	DGND	H/L
G	VDDQ	DQ1	VDDQ	VDDQ	DQ0	VDDQ
	1.8 V	H/L	1.8 V	1.8 V	H/L	1.8 V
H	DQ4	VSSQ	DQ3	DQ2	VSSQ	DQ5
	H/L	DGND	H/L	H/L	DGND	H/L
J	VDDL	VREF	VSS	VSSDL	CK	VDD
	1.8 V	0.9 V	DGND	1.8 V	H/L	1.8 V
K		CKE	/WE	/RAS	/CK	ODT
		H/L	H/L	H/L	H/L	1.8 V
L	BA2	BA0	BA1	/CAS	/CS	
	H/L	H/L	H/L	H/L	H/L	
M		A10/AP	A1	A2	A0	VDD
		H/L	H/L	H/L	H/L	1.8 V
N	VSS	A3	A5	A6	A4	
	DGND	H/L	H/L	H/L	H/L	
P		A7	A9	A11	A8	VSS
		H/L	H/L	H/L	H/L	DGND
R	VDD	A12	RFU	RFU	RFU	
	1.8 V	H/L	DGND	DGND	H/L	

IC1002 (SDIN5D2-4G), 153 BALLS														
EAN62328201 (TOP VIEW: see balls through package)														
	1	2	3	4	5	6	7	8	9	10	11	12	13	14
A	NC	NC	DAT0	DAT1	DAT2	NC	NC	NC	NC	NC	NC	NC	NC	NC
	-	-	H/L	H/L	H/L	-	-	-	-	-	-	-	-	-
B	NC	DAT3	DAT4	DAT5	DAT6	DAT7	NC	NC	NC	NC	NC	NC	NC	NC
	-	H/L	H/L	H/L	H/L	H/L	-	-	-	-	-	-	-	-
C	NC	VDDi	NC	VSSQ	NC	VCCQ	NC	NC	NC	NC	NC	NC	NC	NC
	-	DGND	-	DGND	-	3.3 V	-	-	-	-	-	-	-	-
D	NC	NC	NC	NC	NC	NC	NC	NC	NC	NC	NC	NC	NC	NC
	-	-	-	-	-	-	-	-	-	-	-	-	-	-
E	NC	NC	NC	NC	NC	VCC	VSS	NC	NC	NC	NC	NC	NC	NC
	-	-	-	-	-	3.3 V	DGND	-	-	-	-	-	-	-
F	NC	NC	NC	NC	VCC	NC	NC	NC	NC	NC	NC	NC	NC	NC
	-	-	-	-	3.3 V	-	-	-	-	-	-	-	-	-
G	NC	NC	NC	NC	VSS	NC	NC	NC	NC	NC	NC	NC	NC	NC
	-	-	-	-	DGND	-	-	-	-	-	-	-	-	-
H	NC	NC	NC	NC	NC	NC	NC	NC	NC	VSS	NC	NC	NC	NC
	-	-	-	-	-	-	-	-	-	DGND	-	-	-	-
J	NC	NC	NC	NC	NC	NC	NC	NC	NC	VCC	NC	NC	NC	NC
	-	-	-	-	-	-	-	-	-	3.3 V	-	-	-	-
K	NC	NC	NC	NC	RST_n	NC	NC	VSS	VCC	NC	NC	NC	NC	NC
	-	-	-	-	-	-	-	DGND	3.3 V	-	-	-	-	-
L	NC	NC	NC	NC	NC	NC	NC	NC	NC	NC	NC	NC	NC	NC
	-	-	-	-	-	-	-	-	-	-	-	-	-	-
M	NC	NC	NC	VCCQ	CMD	CLK	NC	NC	NC	NC	NC	NC	NC	NC
	-	-	-	3.3 V	H/L	H/L	-	-	-	-	-	-	-	-
N	NC	VSSQ	NC	VCCQ	VSSQ	NC	NC	NC	NC	NC	NC	NC	NC	NC
	-	DGND	-	3.3 V	DGND	-	-	-	-	-	-	-	-	-
P	NC	NC	VCCQ	VSSQ	VCCQ	VSSQ	NC	NC	NC	NC	NC	NC	NC	NC
	-	-	3.3 V	DGND	3.3 V	DGND	-	-	-	-	-	-	-	-

IC600 (AU1320-667MTJ)
EAN62229101 (TOP VIEW: see balls through package)

	1	2	3	4	5	6	7	8	9	10	11	12	13	14	15	16	17	18	19	20	21	22	23	24	25	
A	NC	GPIO[7]/SD0_DAT5	GPIO[9]/SD0_DAT7	GPIO[4]/EXTCLK0	BOOT[1]	BOOT[2]	TC[0]	TC[2]	FTM	CIM_D[9]	CIM_D[5]	CIM_D[1]	CIM_D[0]	TDO	TRST#	LCD_D[2]	LCD_D[3]	LCD_D[6]	LCD_D[11]	LCD_LCLK	LCD_PCLK	GPIO[31]/LCD_CLKIN	LCD_D[13]	LCD_D[17]	LCD_D[18]	
	-	H/L	H/L	3.3 V	DGND	DGND	DGND	DGND	DGND	DGND	H/L	H/L	-	-	CLK	CLK	H/L	H/L	H/L	H/L	CLK	CLK	DGND	H/L	H/L	H/L
B	SD0_DAT0	VSS	GPIO[10]	VSS	GPIO[3]/SLEEPWAKE[3]	VSS	BOOT[3]	VSS	TESTEN[0]	VSS	CIM_D[6]	VSS	TMS	VSS	LCD_D[1]	VSS	LCD_D[7]	VSS	LCD_BIAS	VSS	LCD_D[12]	VSS	LCD_D[23]	VSS	GPIO[28]/U3TXD	
	H/L	DGND	3.3 V	DGND	DGND	DGND	DGND	DGND	DGND	DGND	H/L	DGND	CLK	DGND	H/L	DGND	H/L	DGND	CLK	DGND	H/L	DGND	H/L	DGND	H/L	
C	GPIO[40]/SD2_DAT2	GPIO[42]/SD2_CMD	SD0_DAT1	SD0_DAT2	GPIO[8]/SD0_DAT6	GPIO[1]/SLEEPWAKE[1]	GPIO[5]/EXTCLK1	RESETOUT#	TC[1]	GPIO[72]/CIM_FS	CIM_D[7]	CIM_D[2]	TCK	GPIO[29]/LCD_PWM0	LCD_D[4]	LCD_D[8]	LCD_FCLK	LCD_D[14]	LCD_D[19]	LCD_D[22]	LCD_D[21]	GPIO[22]/U0CTS#	GPIO[23]/U0RTS#	GPIO[17]/U1RXD	GPIO[13]/U1DSR#	
	3.3 V	H/L	H/L	H/L	H/L	DGND	3.3 V	H/L	DGND	DGND	H/L	H/L	CLK	3.3 V	H/L	H/L	CLK	H/L	H/L	H/L	H/L	H/L	3.3 V	H/L	H/L	
D	XPWR12	GPIO[39]/SD2_DAT1	VDDX	SD0_CMD	VDDX	GPIO[6]/SD0_DAT4	VDDX	BOOT[0]	VDDX	CIM_CLK	VDDX	CIM_D[3]	VDDX	GPIO[30]/LCD_PWM1	VDDX	LCD_D[9]	VDDX	LCD_D[16]	VDDX	GPIO[24]/U0DTR#	VDDX	GPIO[14]/U1CTS#	VDDX	GPIO[25]/U2RXD	U0TXD	
	1.1 V	H/L	3.3 V	H/L	3.3 V	H/L	3.3 V	DGND	3.3 V	CLK	3.3 V	H/L	3.3 V	3.3 V	3.3 V	H/L	3.3 V	H/L	3.3 V	3.3 V	3.3 V	H/L	3.3 V	H/L	H/L	
E	XTI12	XTO12	GPIO[43]/SD2_CLK	GPIO[41]/SD2_DAT3	SD0_CLK	SD0_DAT3	GPIO[0]/SLEEPWAKE[0]	GPIO[2]/SLEEPWAKE[2]	TC[3]	CIM_D[8]	GPIO[71]/CIM_LS	CIM_D[4]	TESTEN[1]	TDI	LCD_D[0]	LCD_D[5]	LCD_D[10]	LCD_D[15]	LCD_D[20]	U0RXD	GPIO[27]/U3RXD	GPIO[19]/U0RI#	GPIO[20]/U0DCD#	GPIO[18]/U1TXD	GPIO[16]/U1DTR#	
	CLK (12 MHz)	-	3.3 V	3.3 V	CLK	H/L	H/L	DGND	DGND	H/L	DGND	H/L	DGND	CLK	H/L	H/L	H/L	H/L	H/L	H/L	H/L	3.3 V	CLK	H/L	3.3 V	
F	XAGND32	VSS	XAGND12	GPIO[38]/SD2_DAT0	PWR_EN	VSS	VDDI	VSS	VDDI	VSS	VDDI	VSS	VDDI	VSS	VDDI	VSS	VDDI	VSS	VDDI	VSS	GPIO[26]/U2TXD	GPIO[21]/U0DSR#	GPIO[15]/U1RTS#	VSS	GPIO[12]/U1DCD#	
	DGND	DGND	DGND	H/L	-	DGND	1.1 V	DGND	1.1 V	DGND	1.1 V	DGND	1.1 V	DGND	1.1 V	DGND	1.1 V	DGND	1.1 V	DGND	H/L	H/L	3.3 V	DGND	3.3 V	
G	XTO32	XTI32	XAG-ND AUXPLL	VDDX	XPWRAUXPLL	VDDI	NC	NC	NC	NC	NC	NC	NC	NC	NC	NC	NC	NC	NC	NC	VDDI	GPIO[11]/U1RI#	VDDX	GPIO[60]/PSC3_D0	GPIO[61]/PSC3_D1	GPIO[74]/PSC3_CLK
	-	CLK (32.768 kHz)	3.3 V	3.3 V	3.3 V	1.1 V	-	-	-	-	-	-	-	-	-	-	-	-	-	-	1.1 V	3.3 V	3.3 V	H/L	3.3 V	CLK
H	XPWR32	VSS	RESETIN#	XPWRCPU-PLL	XAGND CPU-PLL	VSS	NC	NC	NC	NC	NC	NC	NC	NC	NC	NC	NC	NC	NC	NC	VSS	GPIO[58]/PSC3_SYNC0	GPIO[59]/PSC3_SYNC1	GPIO[57]/PSC2_D1	VSS	GPIO[54]/PSC2_SYNC0
	1.1 V	3.3 V	3.3 V	H/L	3.3 V	CLK	-	-	-	-	-	-	-	-	-	-	-	-	-	-	3.3 V	DGND	H/L	3.3 V	3.3 V	DGND
J	GPIO[34]/SD1_DAT2	GPIO[35]/SD1_DAT3	GPIO[36]/SD1_CMD	VDDX	FWTOY#	VDDI	NC	NC	VSS	VSS	VSS	VSS	VSS	VSS	VSS	VSS	VSS	VSS	NC	NC	VDDI	GPIO[56]/PSC2_D0	VDDX	GPIO[55]/PSC2_SYNC1	GPIO[73]/PSC2_CLK	GPIO[52]/PSC1_D0
	3.3 V	3.3 V	3.3 V	3.3 V	H/L	1.1 V	-	-	DGND	DGND	DGND	DGND	DGND	DGND	DGND	DGND	DGND	DGND	DGND	DGND	DGND	1.1 V	H/L	3.3 V	CLK(11.2896 MHz)	H/L
K	GPIO[33]/SD1_DAT1	VSS	GPIO[37]/SD1_CLK	GPIO[32]/SD1_DAT0	WAKE#	VSS	NC	NC	VSS	VSS	VSS	VSS	VSS	VSS	VSS	VSS	VSS	VSS	NC	NC	VSS	GPIO[53]/PSC1_D1	GPIO[50]/PSC1_SYNC0	GPIO[51]/PSC1_SYNC1	VSS	GPIO[45]/PSC1_CLK
	3.3 V	DGND	3.3 V	H/L	3.3 V	DGND	-	-	DGND	DGND	DGND	DGND	DGND	DGND	DGND	DGND	DGND	DGND	DGND	DGND	DGND	H/L	3.3 V	H/L	DGND	CLK
L	HD_CS[1]#	GPIO[62]/PCE[2]#	GPIO[63]/PCE[1]#	VDDX	HD_CS[0]#	VDDI	NC	NC	VSS	VSS	VSS	VSS	VSS	VSS	VSS	VSS	VSS	VSS	NC	NC	VDDI	GPIO[46]/PSC0_SYNC0	VDDX	GPIO[47]/PSC0_SYNC1	GPIO[48]/PSC0_D0	GPIO[49]/PSC0_D1
	-	H/L	H/L	3.3 V	-	1.1 V	-	-	DGND	DGND	DGND	DGND	DGND	DGND	DGND	DGND	DGND	DGND	DGND	DGND	DGND	1.1 V	H/L	3.3 V	3.3 V	H/L
M	GPIO[68]/PREG#	VSS	GPIO[69]/POE#	GPIO[65]/PIOR#	GPIO[64]/PIOS16#	VSS	NC	NC	VSS	VSS	VSS	VSS	VSS	VSS	VSS	VSS	VSS	VSS	NC	NC	VSS	FTM_CLK	FTM_EN#	FTM_DAT	VSS	GPIO[44]/PSC0_CLK
	3.3 V	DGND	H/L	H/L	3.3 V	DGND	-	-	DGND	DGND	DGND	DGND	DGND	DGND	DGND	DGND	DGND	DGND	DGND	DGND	DGND	3.3 V	DGND	DGND	DGND	CLK
N	GPIO[70]/PIOW#	GPIO[66]/PWE#	RCS[1]#	VDDX	GPIO[67]/PWAIT#	VDDI	NC	NC	VSS	VSS	VSS	VSS	VSS	VSS	VSS	VSS	VSS	VSS	NC	NC	VDDI	FTM_PWR	VDDX	USBATEST	USBHM	USBHP
	H/L	3.3 V	-	3.3 V	H/L	1.1 V	-	-	DGND	DGND	DGND	DGND	DGND	DGND	DGND	DGND	DGND	DGND	DGND	DGND	1.1 V	DGND	3.3 V	-	H/L	H/L

IC600 (AU1320-667MTJ) EAN62229101 (TOP VIEW: see balls through package)																									
	1	2	3	4	5	6	7	8	9	10	11	12	13	14	15	16	17	18	19	20	21	22	23	24	25
P	RCS[3]#	VSS	EWAIT#	RAD[11]	RCS[2]#	VSS	NC	NC	VSS	VSS	VSS	VSS	VSS	VSS	VSS	VSS	VSS	NC	NC	VSS	FTM_SEL#	USBVDDX	USBVDDX	VSS	USB_RKELVIN
	-	DGND	3.3 V	H/L	-	DGND	-	-	DGND	DGND	DGND	DGND	DGND	DGND	DGND	DGND	DGND	-	-	DGND	3.3 V	3.3 V	3.3 V	DGND	DGND
R	RCS[0]#	RAD[10]	RAD[13]	VDDX	RAD[12]	VDDI	NC	NC	VSS	VSS	VSS	VSS	VSS	VSS	VSS	VSS	VSS	NC	NC	USBVDDI	USBVDDX	USBVDDX	VSS	USBXO	USBXI
	H/L	H/L	H/L	3.3 V	H/L	1.1 V	-	-	DGND	DGND	DGND	DGND	DGND	DGND	DGND	DGND	DGND	-	-	1.1 V	3.3 V	3.3 V	DGND	CLK (12 MHz)	CLK (12 MHz)
T	RNB	VSS	RAD[5]	RAD[1]	RAD[8]	VSS	NC	NC	VSS	VSS	VSS	VSS	VSS	VSS	VSS	VSS	VSS	NC	NC	VSS	USBVDDI	USBVDDX	USBVDDX	USBDP	USBDM
	3.3 V	DGND	H/L	H/L	H/L	DGND	-	-	DGND	DGND	DGND	DGND	DGND	DGND	DGND	DGND	DGND	-	-	DGND	1.1 V	3.3 V	3.3 V	H/L	H/L
U	RAD[14]	RAD[6]	RAD[7]	VDDX	RAD[2]	VDDI	NC	NC	VSS	VSS	VSS	VSS	VSS	VSS	VSS	VSS	VSS	NC	NC	VDDI	D1_A[4]	USBVDDX	VSS	USBOTGID	USBVBUS
	H/L	H/L	H/L	3.3 V	H/L	1.1 V	-	-	DGND	DGND	DGND	DGND	DGND	DGND	DGND	DGND	DGND	-	-	1.1 V	H/L	3.3 V	DGND	H/L	H/L
V	RAD[9]	VSS	RBE[0]#	RCLK	RDMACK#	VSS	NC	NC	NC	NC	NC	NC	NC	NC	NC	NC	NC	NC	NC	VSS	USBVDDX	D1_A[7]	D1_A[6]	D1_A[5]	D1_A[3]
	H/L	DGND	-	-	-	DGND	-	-	-	-	-	-	-	-	-	-	-	-	-	DGND	3.3 V	H/L	H/L	H/L	H/L
W	RAD[4]	RAD[0]	RDMARQ	VDDX	RD[6]	VDDI	NC	NC	NC	NC	NC	NC	NC	NC	NC	NC	NC	NC	NC	VDDI	D1_A[11]	VDDY	D1_A[10]	D1_A[2]	D1_A[1]
	H/L	H/L	DGND	3.3 V	H/L	1.1 V	-	-	-	-	-	-	-	-	-	-	-	-	-	1.1 V	H/L	1.8 V	H/L	H/L	H/L
Y	RAD[3]	VSS	ROE#	RD[5]	RD[2]	VSS	VDDI	VSS	VDDI	VSS	VDDI	VSS	VDDI	VSS	VDDI	VSS	VDDI	VSS	VDDI	VSS	D1_RAS#	D1_BA[0]	D1_A[8]	VSS	D1_BA[2]
	H/L	DGND	H/L	H/L	H/L	DGND	1.1 V	DGND	1.1 V	DGND	1.1 V	DGND	1.1 V	DGND	1.1 V	DGND	1.1 V	DGND	1.1 V	DGND	H/L	H/L	H/L	DGND	H/L
AA	RBE[1]#	RCLE	RD[14]	RD[3]	RD[0]	D0_A[4]	D0_A[6]	D0_A[10]	D0_A[11]	D0_RAS#	D0_WE#	D0_DQ[15]	D0_DQS[1]	D0_DQS[1]#	D0_DQ[9]	D0_DQ[10]	D1_DQ[9]	D1_DQ[12]	D1_DQ[14]	D_VREF	D1_WE#	VDDY	D1_A[12]	D1_BA[1]	D1_A[0]
	-	-	H/L	H/L	H/L	H/L	H/L	H/L	H/L	H/L	H/L	H/L	H/L	H/L	H/L	H/L	H/L	H/L	H/L	H/L	0.9 V	H/L	1.8 V	H/L	H/L
AB	RALE	VSS	RD[12]	RD[1]	VDDY	D0_A[3]	VDDY	D0_A[0]	VDDY	D0_CAS#	VDDY	D0_DQ[13]	VDDY	D0_DQ[3]	VDDY	D0_DQ[8]	VDDY	D1_DM[1]	VDDY	D1_DQ[3]	VDDY	D1_CK	D1_CKE	VSS	D1_A[9]
	H/L	DGND	H/L	H/L	1.8 V	H/L	1.8 V	-	1.8 V	H/L	1.8 V	H/L	1.8 V	H/L	1.8 V	H/L	1.8 V	H/L	1.8 V	H/L	1.8 V	H/L	H/L	DGND	H/L
AC	RWE#	RD[7]	RD[11]	RD[8]	DDRIVE_PADLO	D0_A[5]	D0_A[7]	D0_BA[1]	D0_BA[0]	D0_CS#	D0_DQ[12]	D0_DQ[1]	D0_DM[1]	D_VREF	D0_DQ[0]	D0_DM[0]	D1_DQ[8]	D1_DQ[7]	D1_DM[0]	D1_DQS[1]#	D1_DQ[4]	D1_DQ[10]	D1_CK#	D1_CAS#	D1_A[13]
	H/L	H/L	H/L	H/L	1.8 V	H/L	H/L	H/L	H/L	H/L	H/L	H/L	H/L	H/L	H/L	H/L	H/L	H/L	H/L	H/L	H/L	H/L	H/L	H/L	-
AD	RD[15]	VSS	RD[10]	VSS	DDRIVE_PADHI	VSS	D0_BA[2]	VSS	D0_A[12]	VSS	D0_DQ[7]	VSS	D0_DQ[4]	VSS	D0_DQ[2]	VSS	D0_CK	VSS	D1_DQ[2]	VSS	D1_DQS[1]	VSS	D1_DQ[6]	VDDY	D1_CS#
	H/L	DGND	H/L	DGND	DGND	DGND	H/L	DGND	H/L	DGND	H/L	DGND	H/L	DGND	H/L	DGND	H/L	DGND	H/L	DGND	H/L	DGND	H/L	1.8 V	H/L
AE	RD[13]	RD[4]	RD[9]	VDDXOK	D0_A[1]	D0_A[2]	D0_A[8]	D0_A[9]	D0_A[13]	D0_CKE	D0_DQ[11]	D0_DQ[6]	D0_DQ[5]	D0_DQS[0]#	D0_DQS[0]	D0_DQ[14]	D0_CK#	D1_DQ[0]	D1_DQ[1]	D1_DQ[15]	D1_DQS[0]	D1_DQS[0]#	D1_DQ[13]	D1_DQ[5]	D1_DQ[11]
	H/L	H/L	H/L	H/L	H/L	H/L	H/L	H/L	H/L	H/L	H/L	H/L	H/L	H/L	H/L	H/L	H/L	H/L	H/L	H/L	H/L	H/L	H/L	H/L	H/L

BLOCK DIAGRAMS

1. FUNCTION BLOCK DIAGRAM

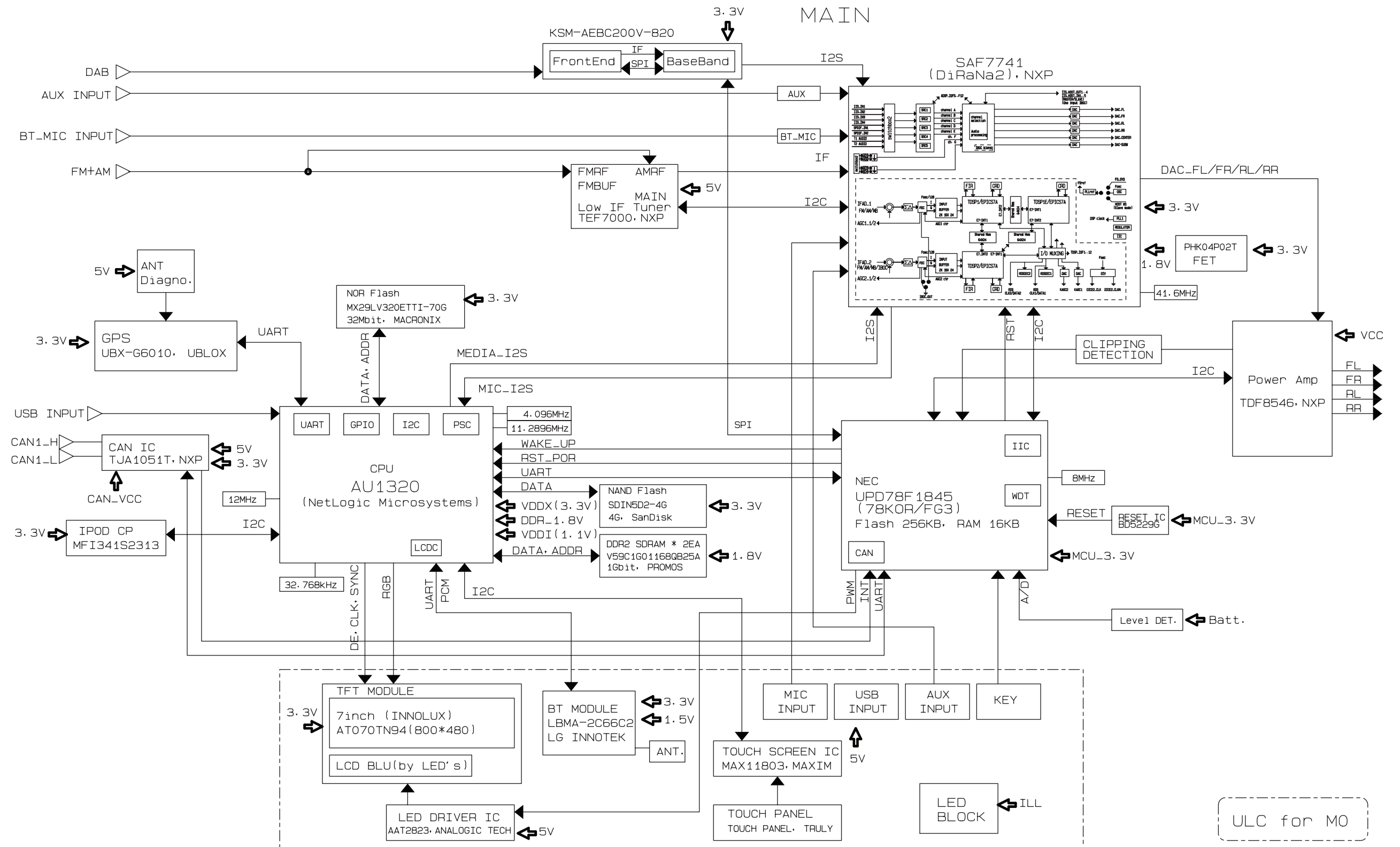

2. H/W BLOCK DIAGRAM

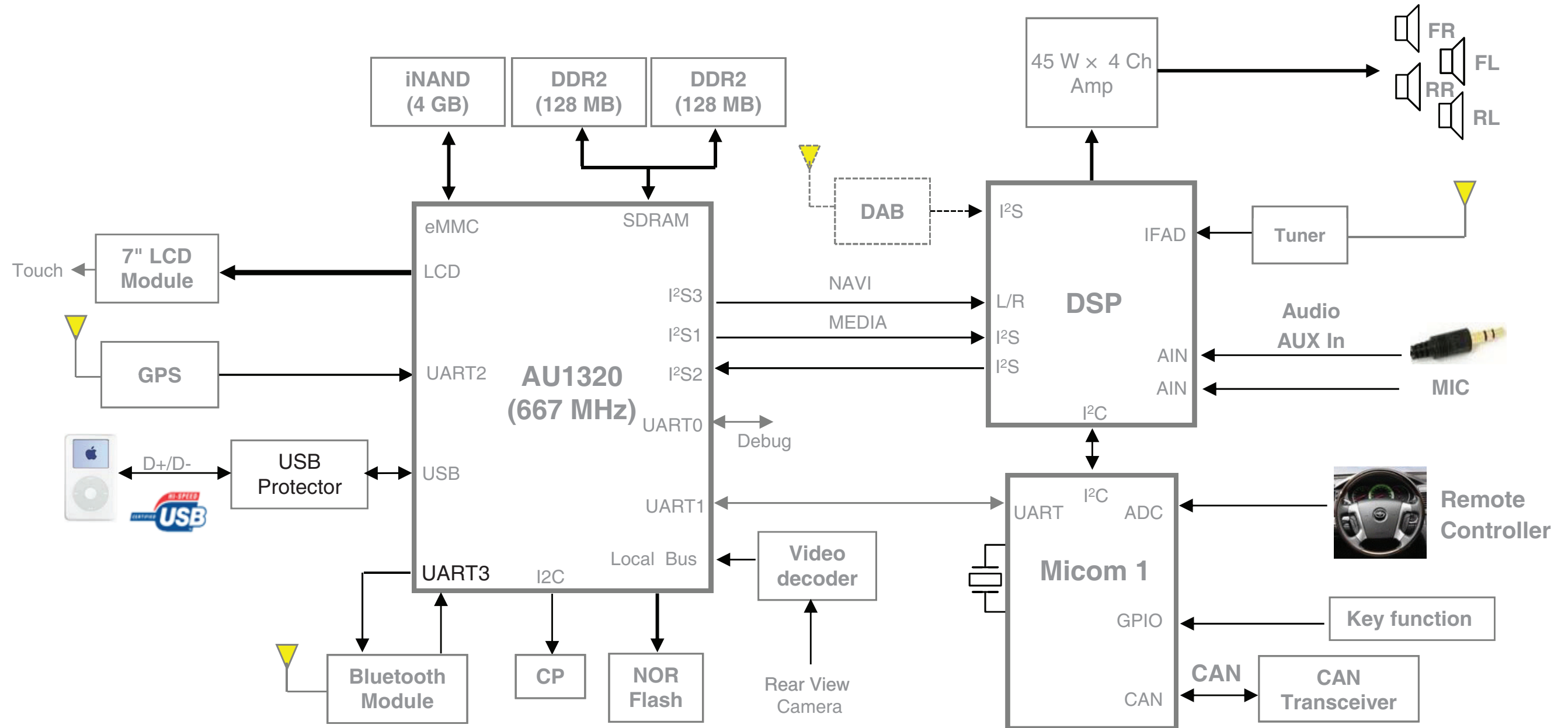

3. S/W BLOCK DIAGRAM

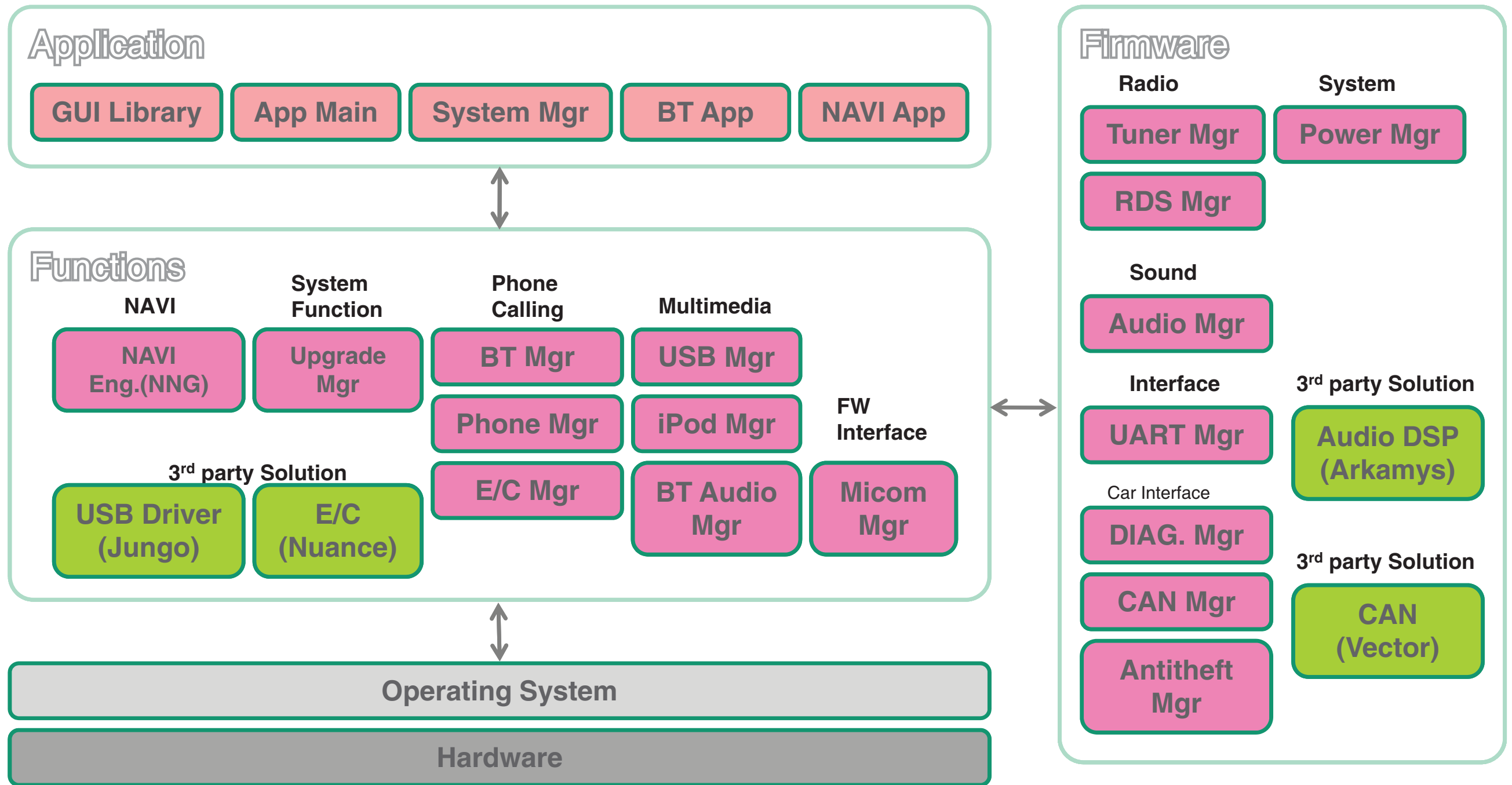

4. FRONT BLOCK DIAGRAM

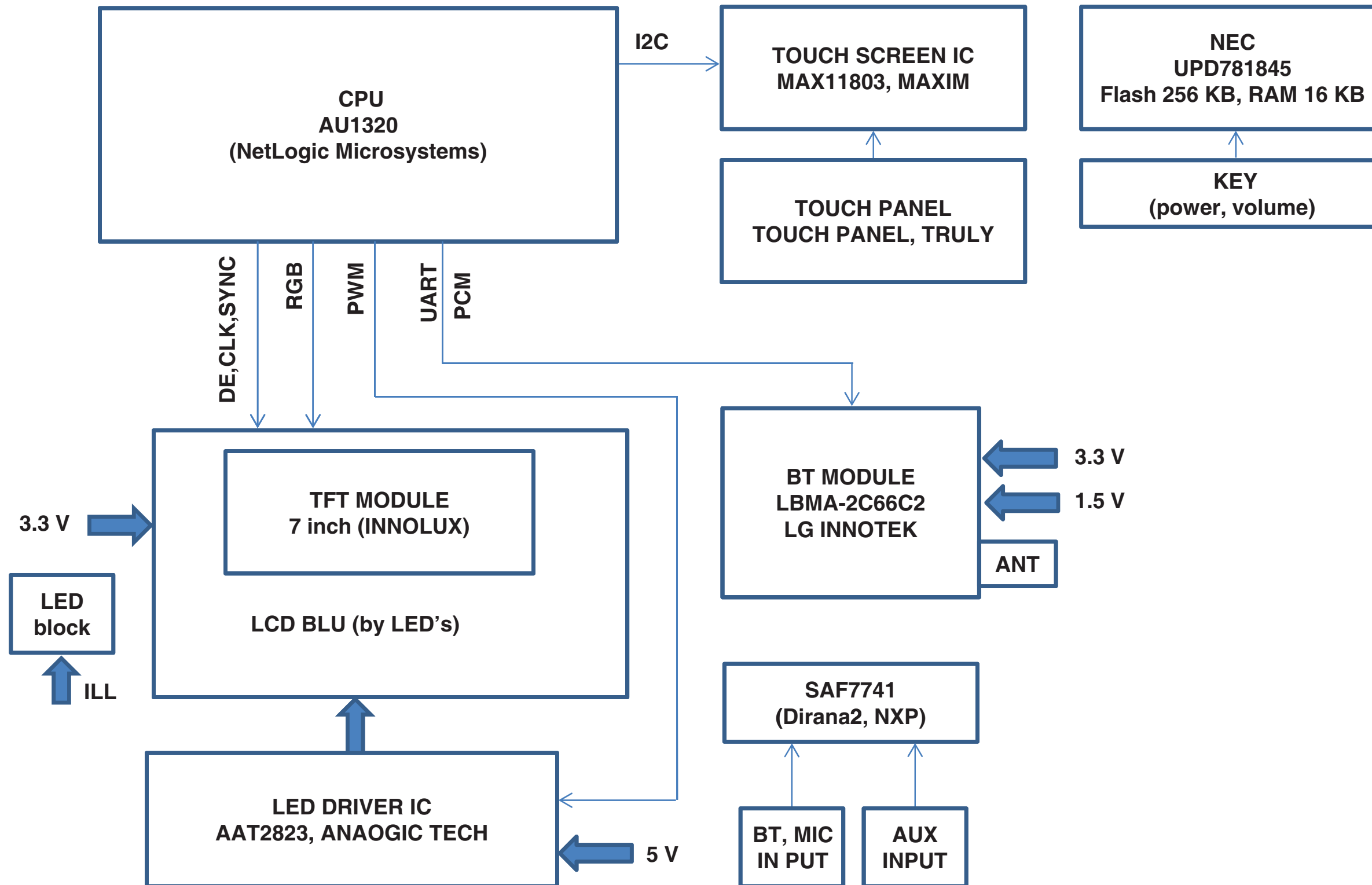

5. AUDIO BLOCK DIAGRAM

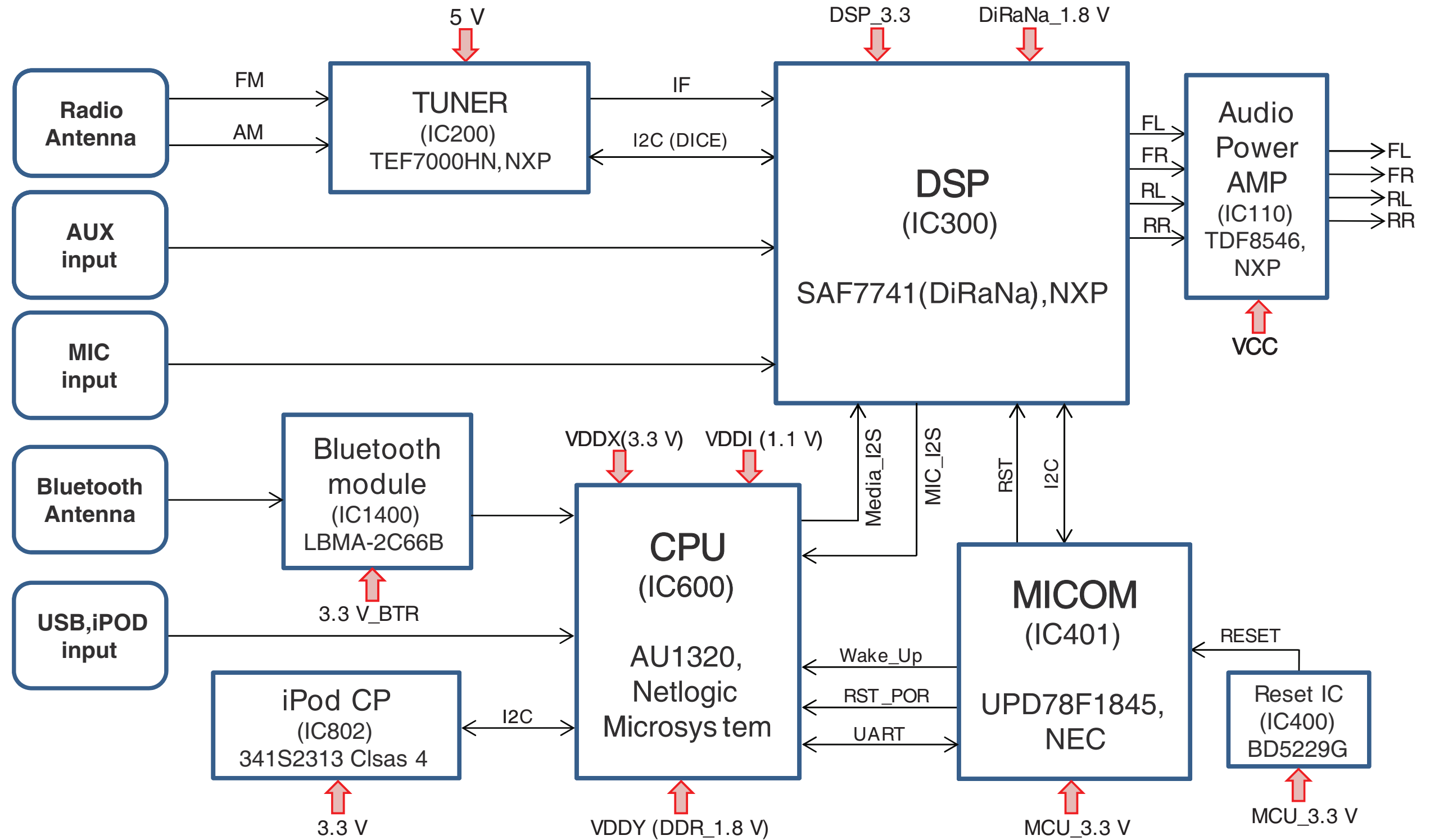

6. POWER BLOCK DIAGRAM

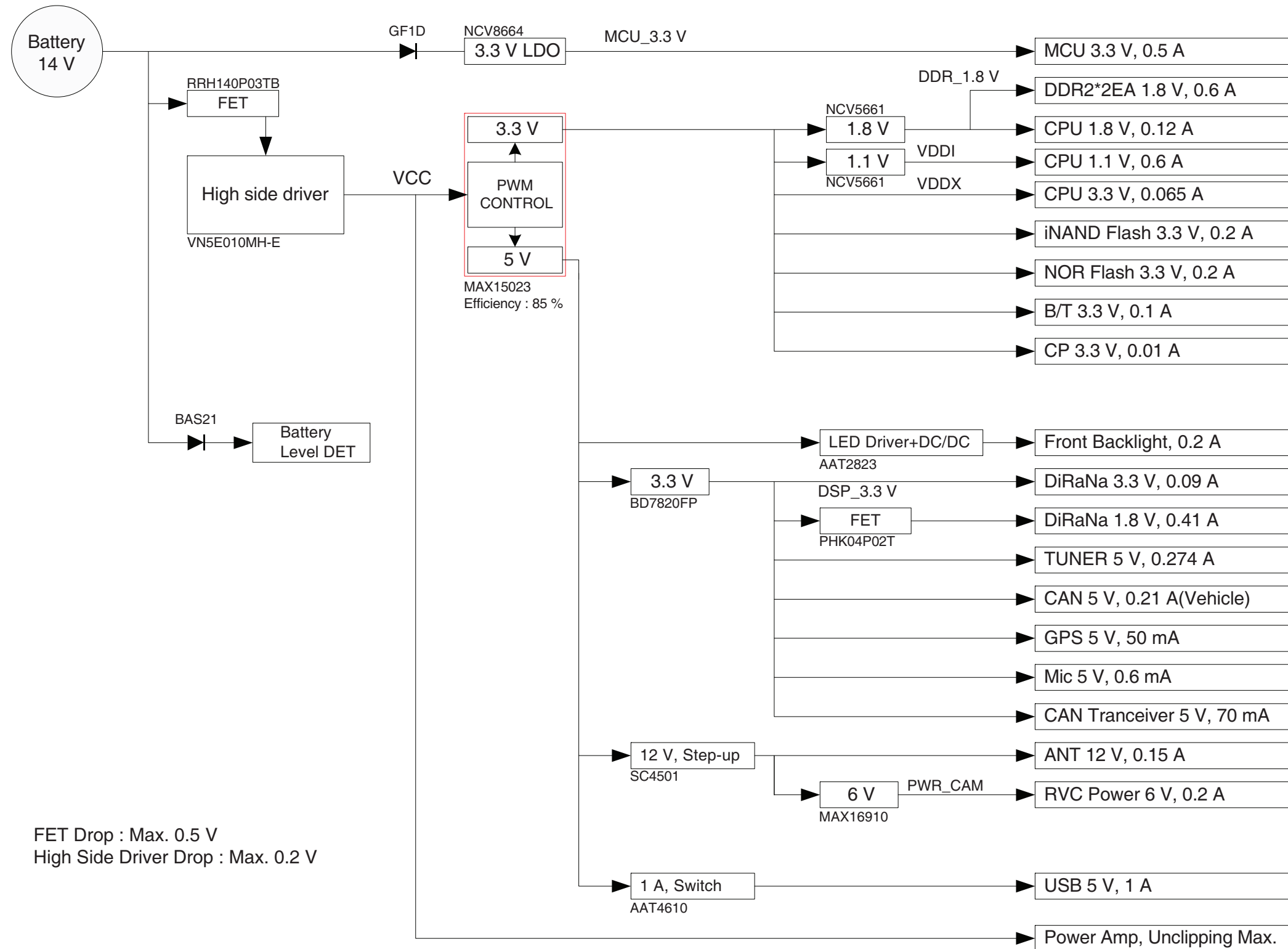

7. GPS BLOCK DIAGRAM

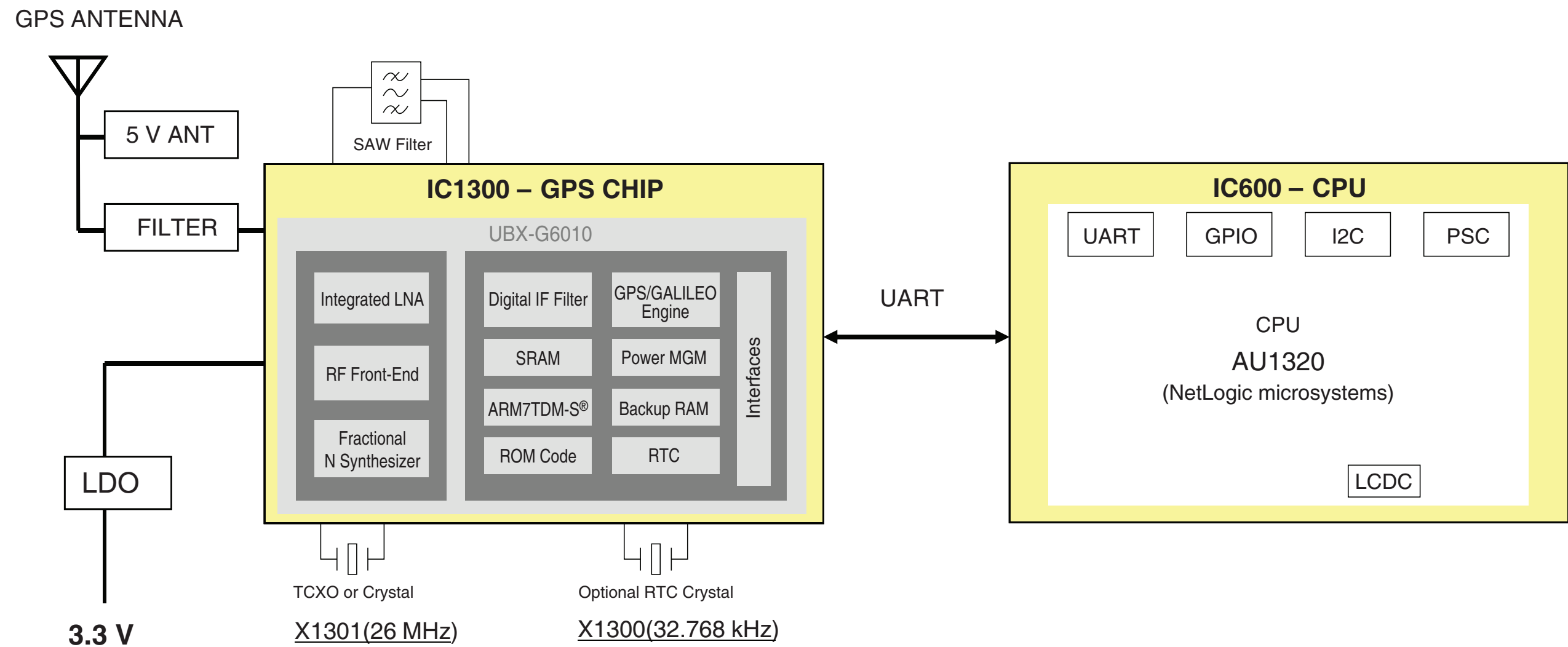

CIRCUIT DIAGRAMS

1. FRONT CIRCUIT DIAGRAM

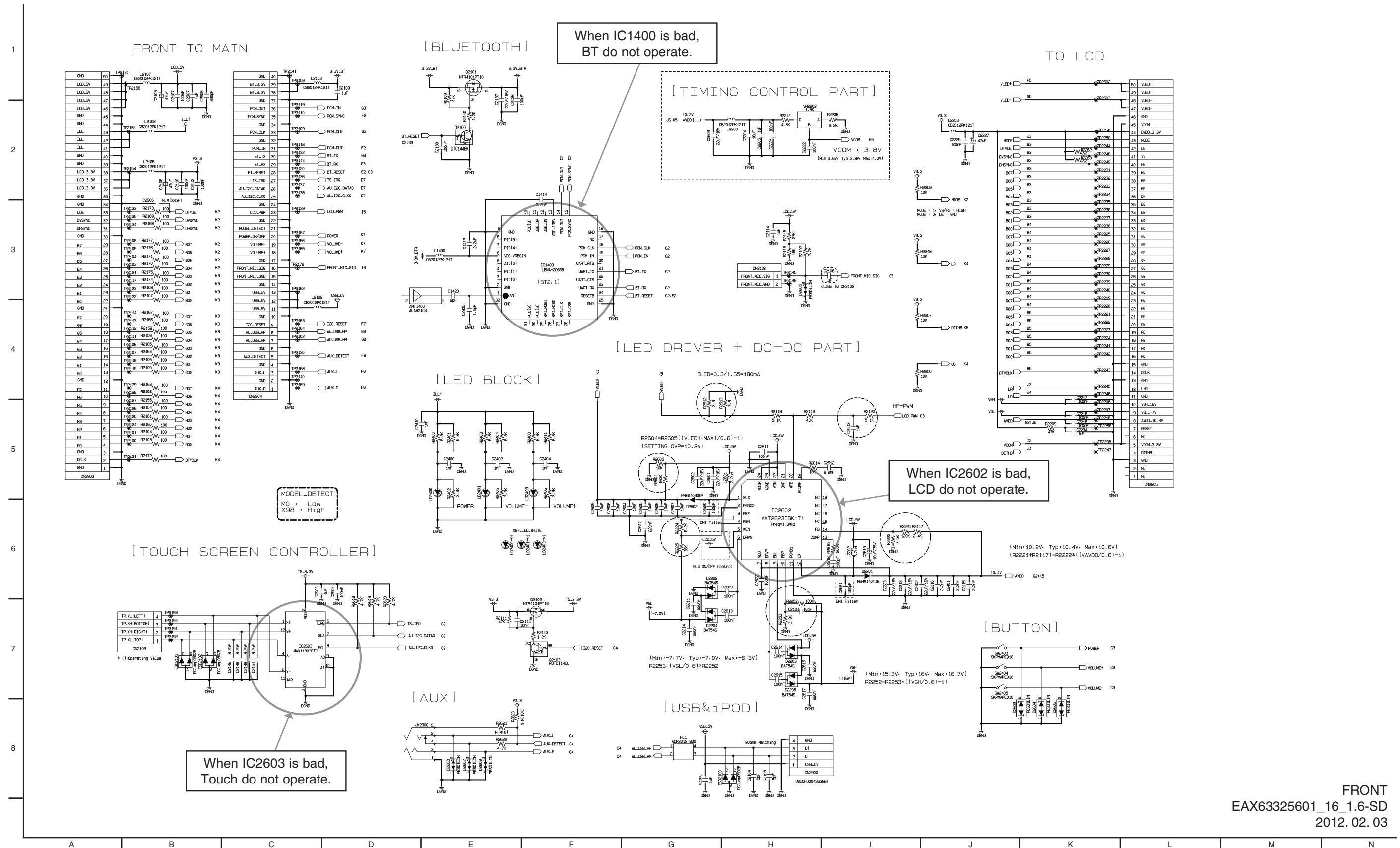

2. MAIN - POWER + AMPLIFIER CIRCUIT DIAGRAM

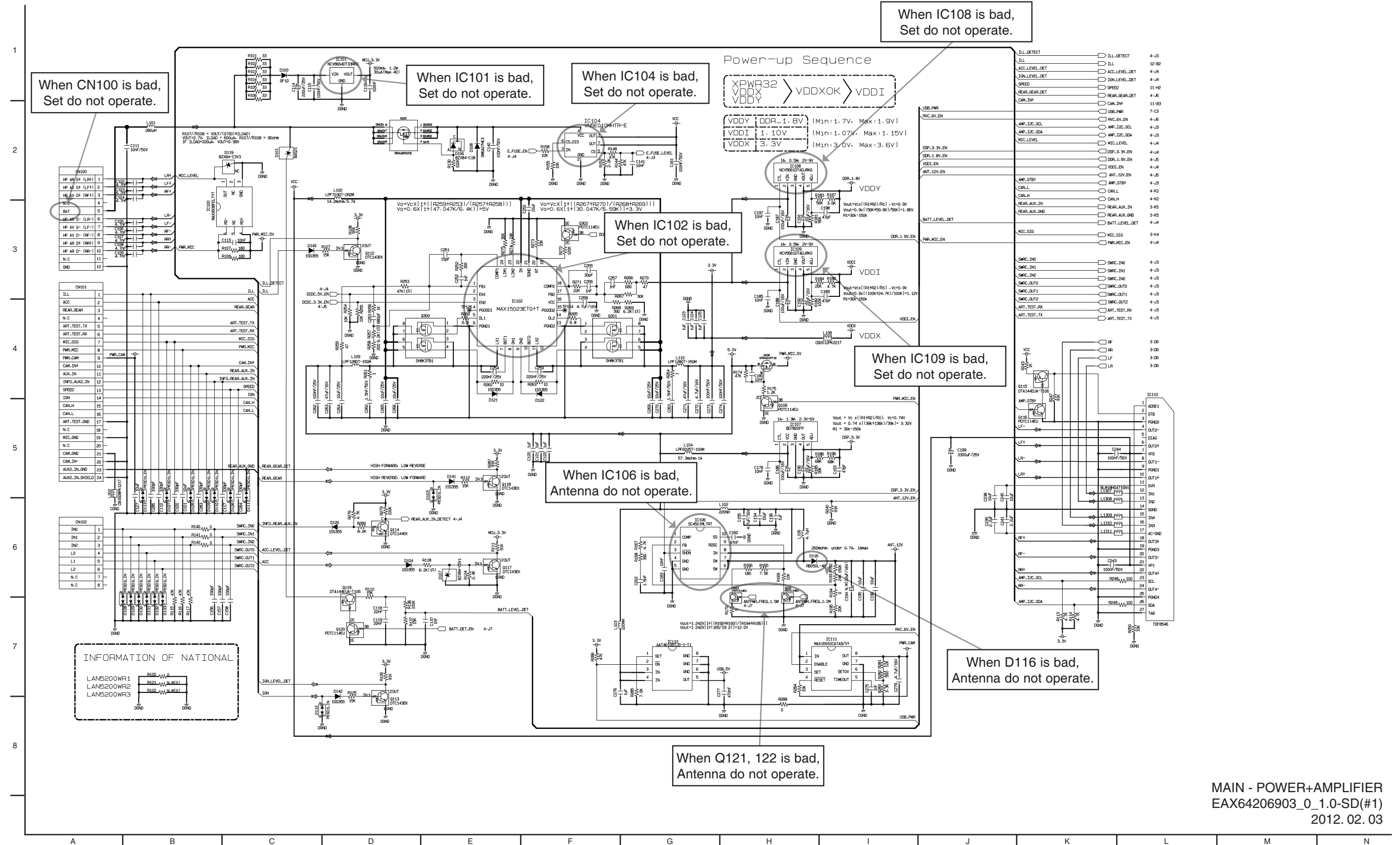

3. MAIN - SINGLE RF TUNER(LEAF DICE) CIRCUIT DIAGRAM

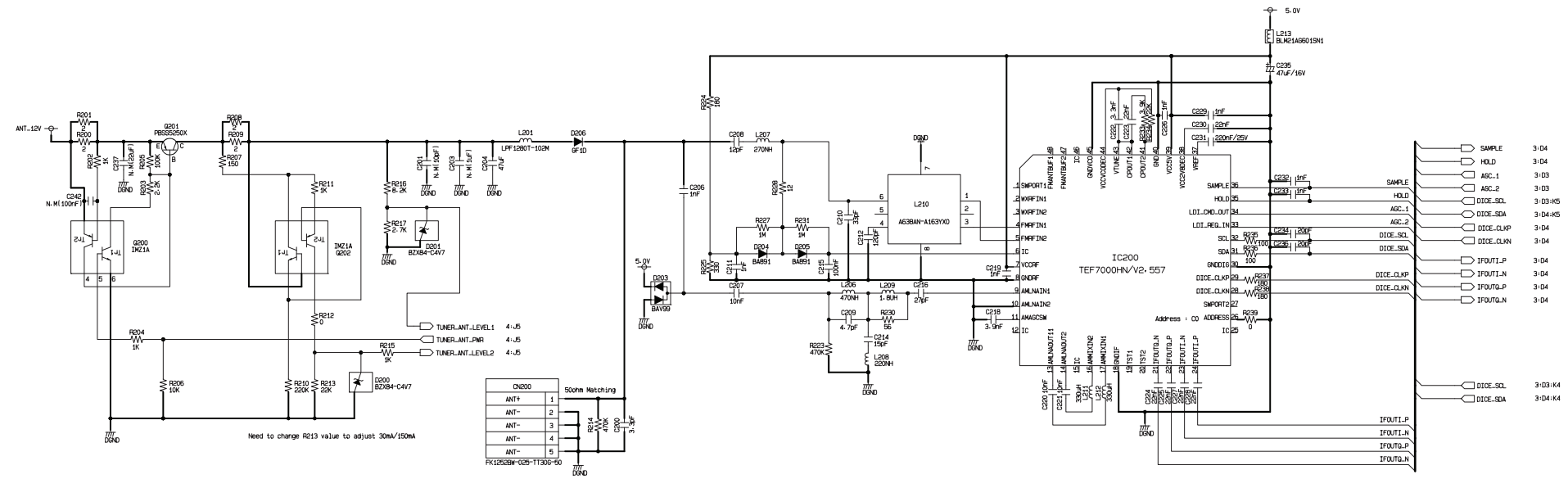

MAIN - SINGLE RF TUNER(LEAF DICE)
EAX64206903_0_1.0-SD(#2)
2012. 02. 03

4. MAIN - DSP(DiRaNa2) CIRCUIT DIAGRAM

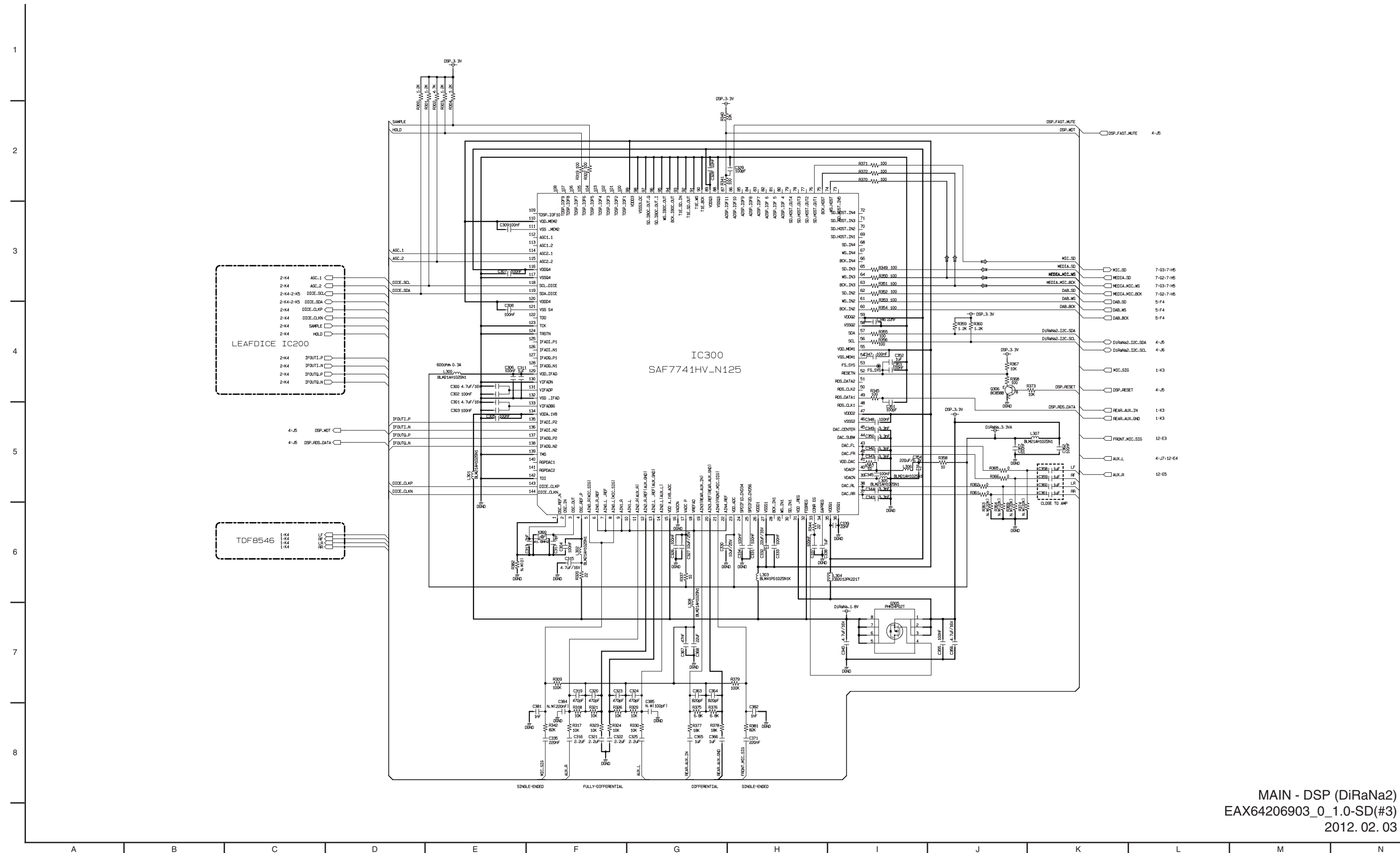

MAIN - DSP (DiRaNa2)
EAX64206903_0_1.0-SD(#3)
2012. 02. 03

5. MAIN - MICOM + CAN CIRCUIT DIAGRAM

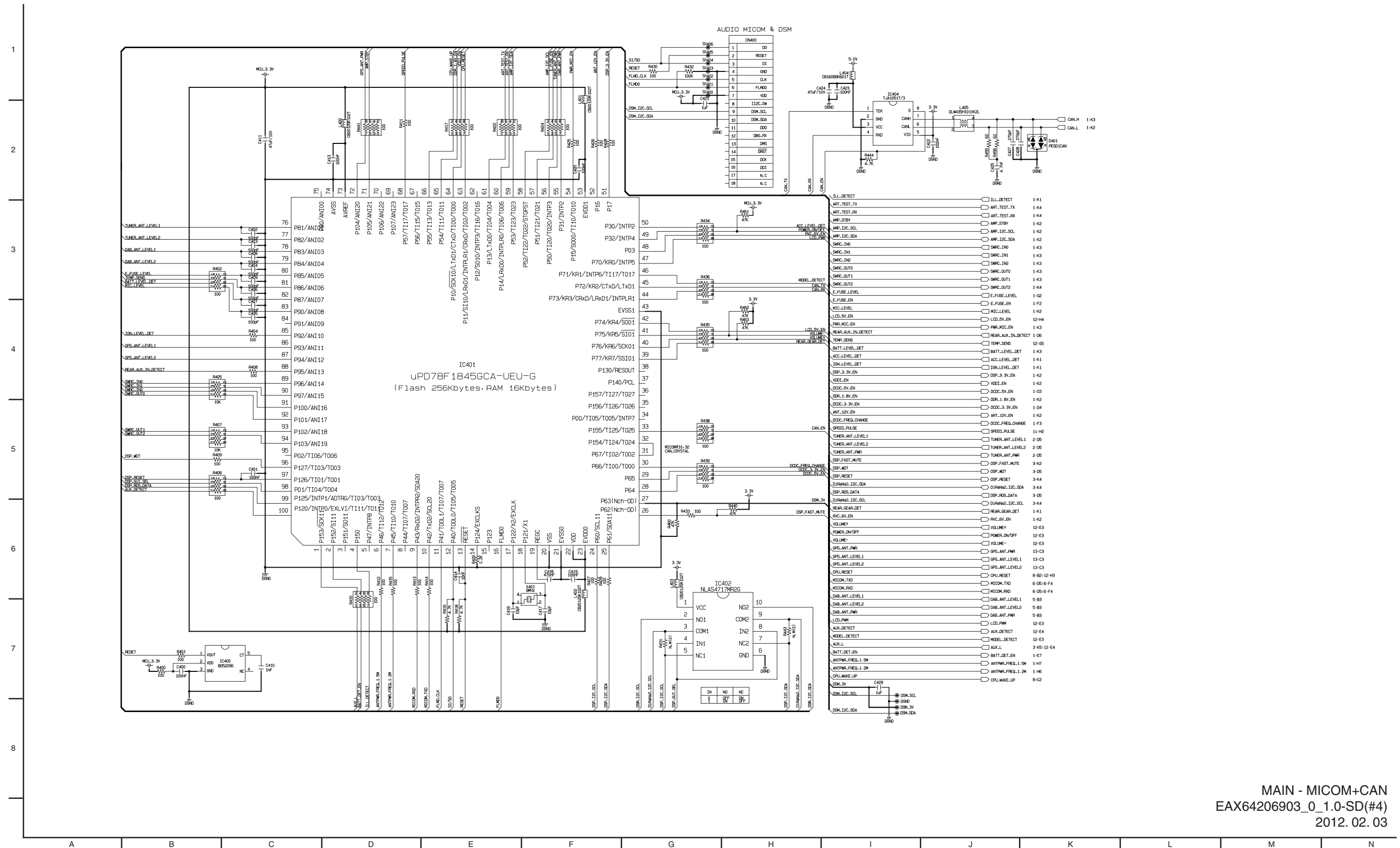

6. MAIN - DAB CIRCUIT DIAGRAM

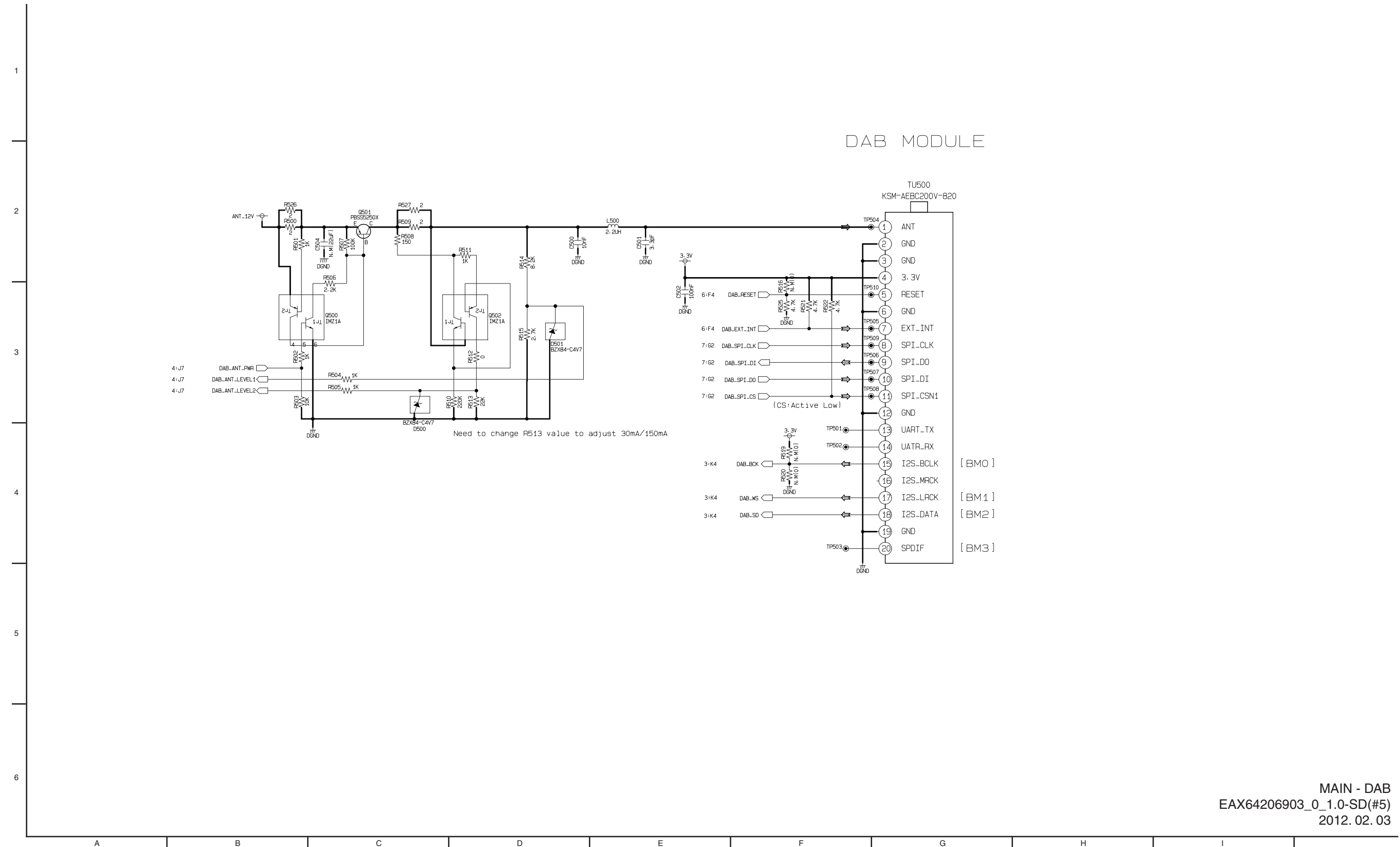

7. MAIN - AU1320 LCD & USB & UART CIRCUIT DIAGRAM

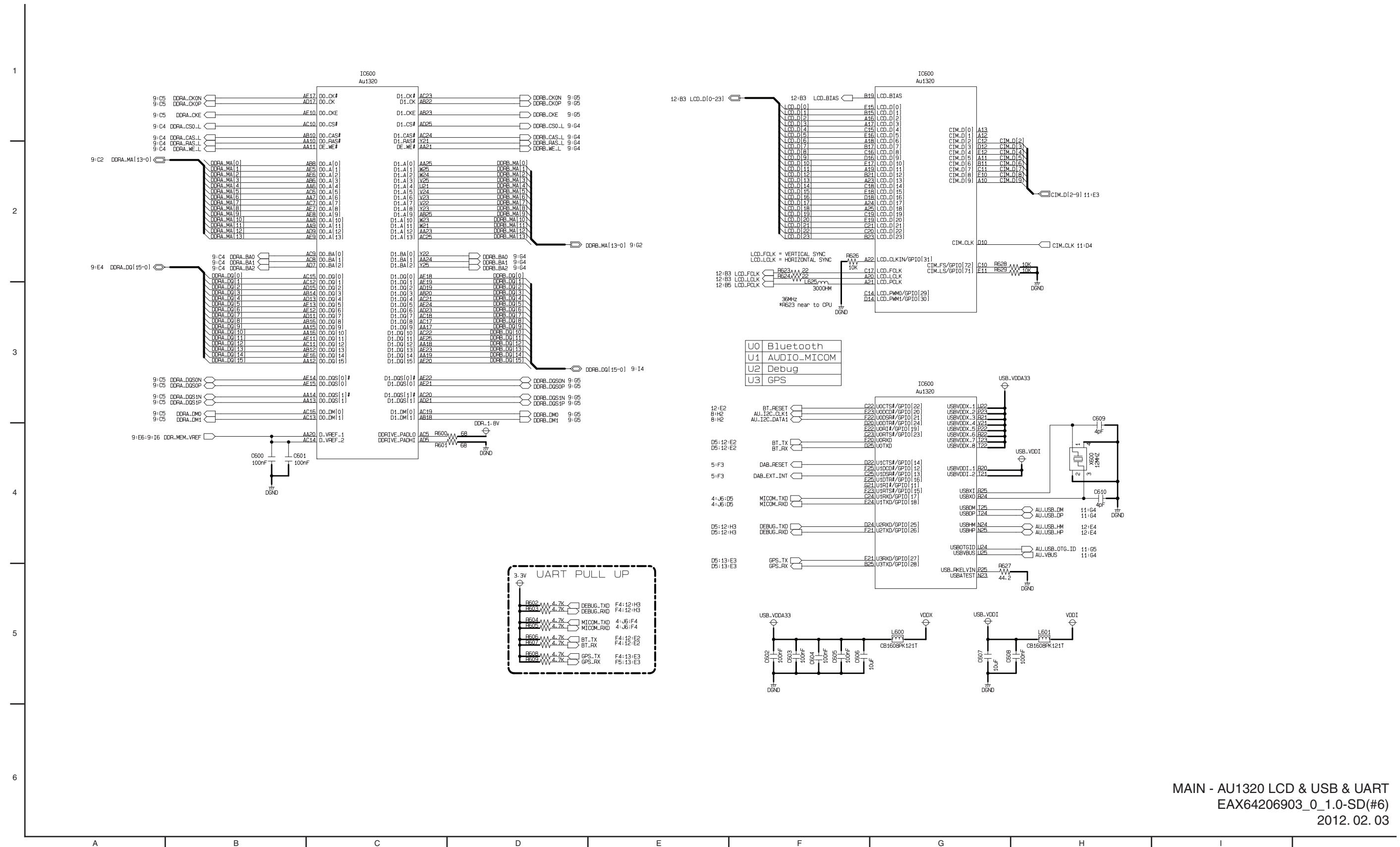

8. MAIN - AU1320 BUS & PSC CIRCUIT DIAGRAM

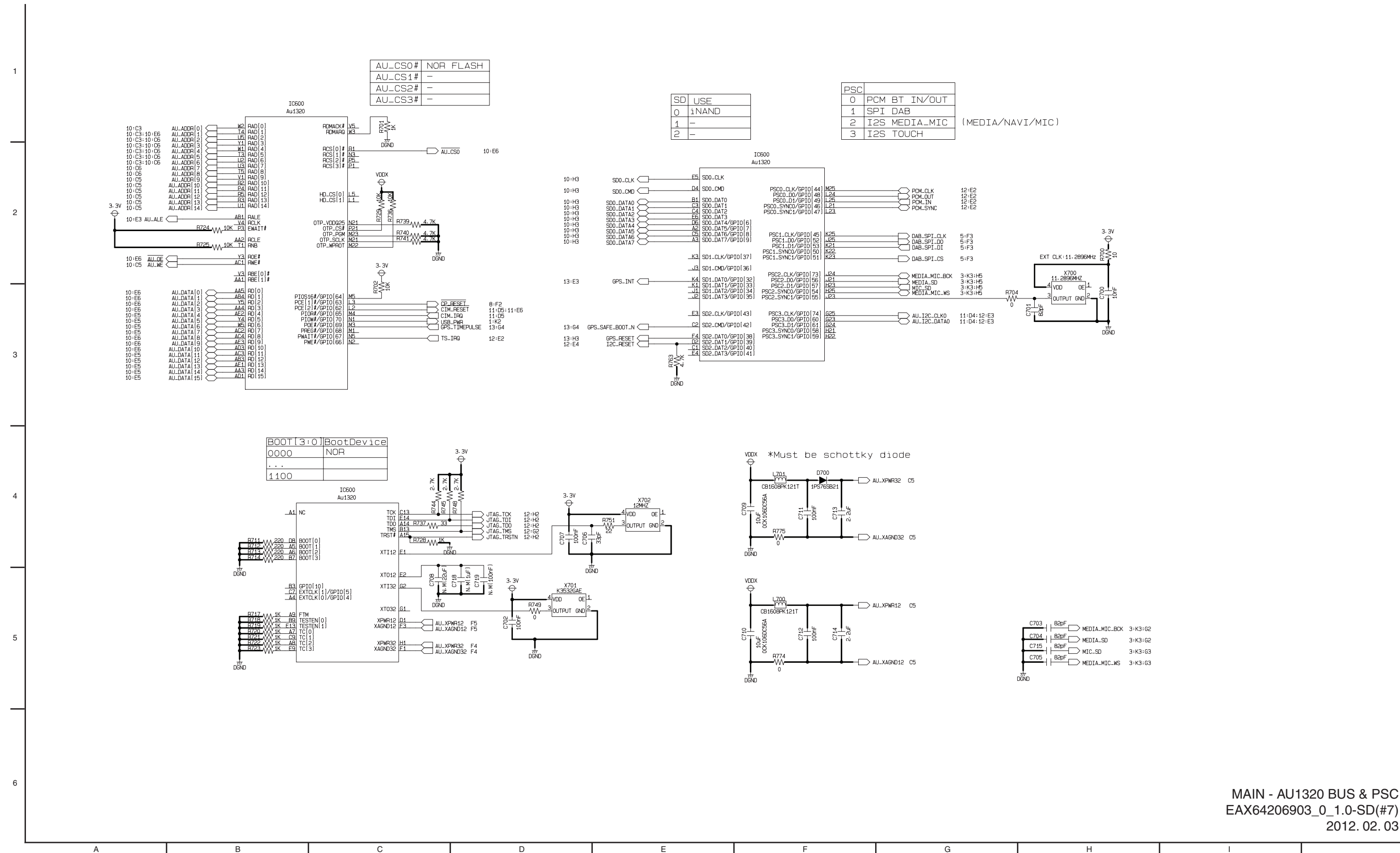

9. MAIN - AU1320 VDD & BOOT & RESET / IPOD CP CIRCUIT DIAGRAM

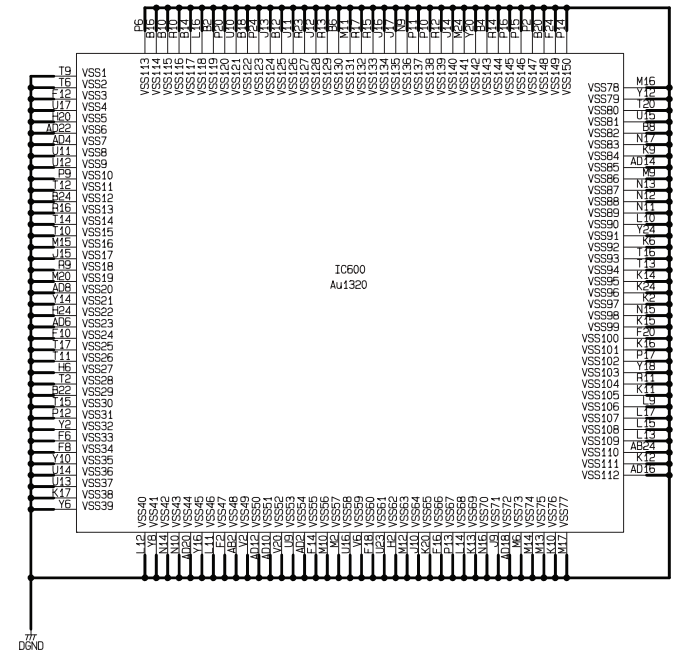
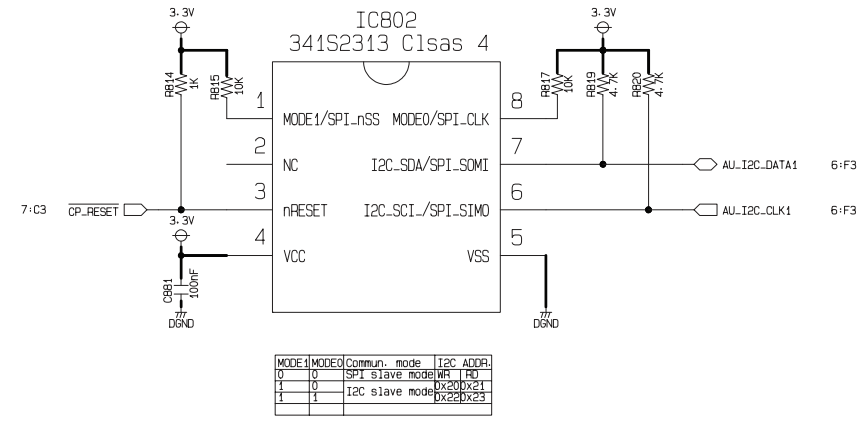
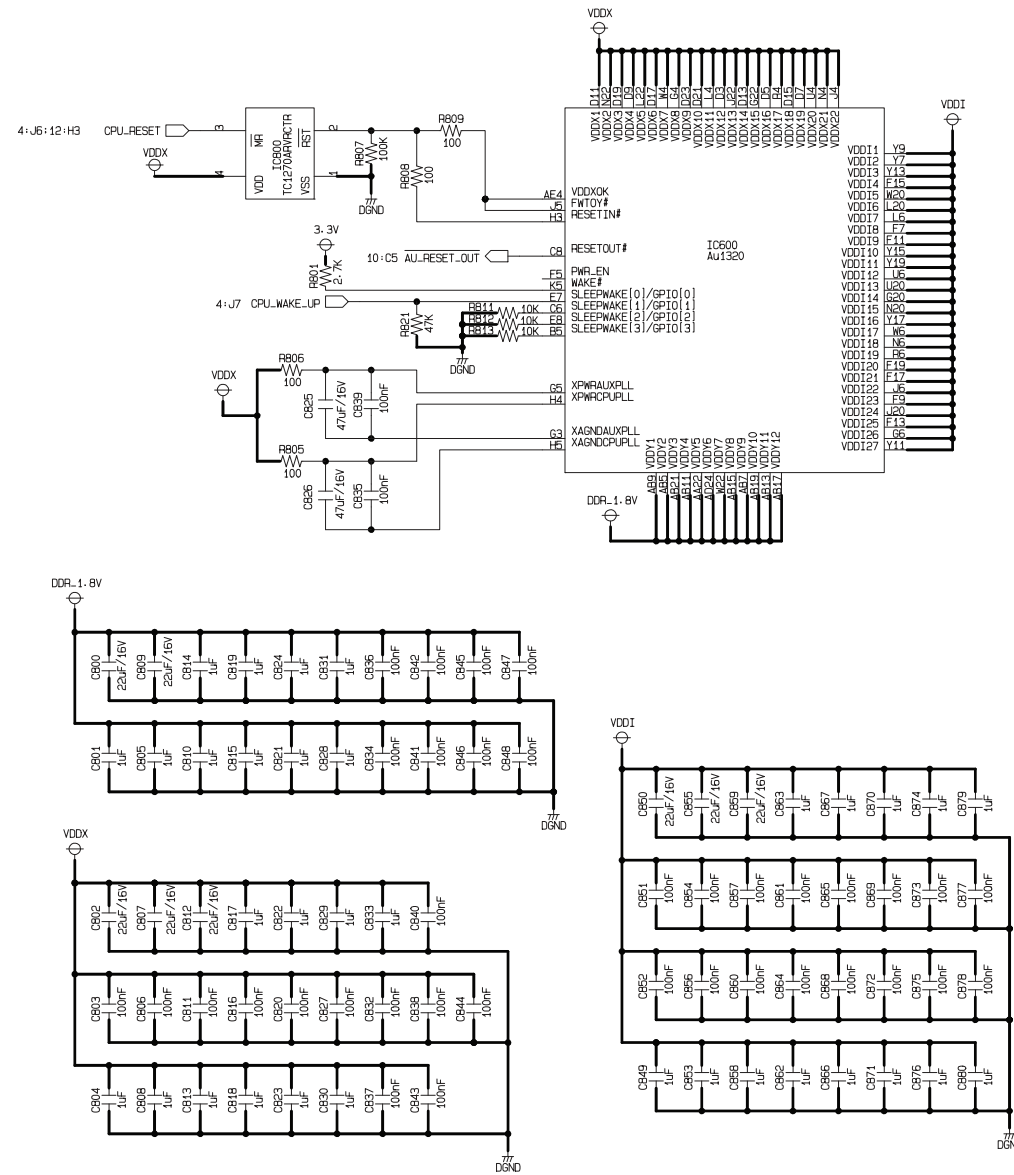

MAIN - AU1320 VDD & BOOT & RESET / IPOD CP
 EAX64206903_0_1.0-SD(#8)
 2012.02.03

10. MAIN - DDR2 SDRAM CIRCUIT DIAGRAM

128MByte X 2 : DDR2 Single 32-bit Interface with One Rank
 (V59C1G01168QB, HIGH PERFORMANCE 1Gbit DDR2 SDRAM, 8BANKS X 8Mbit X 16(168))

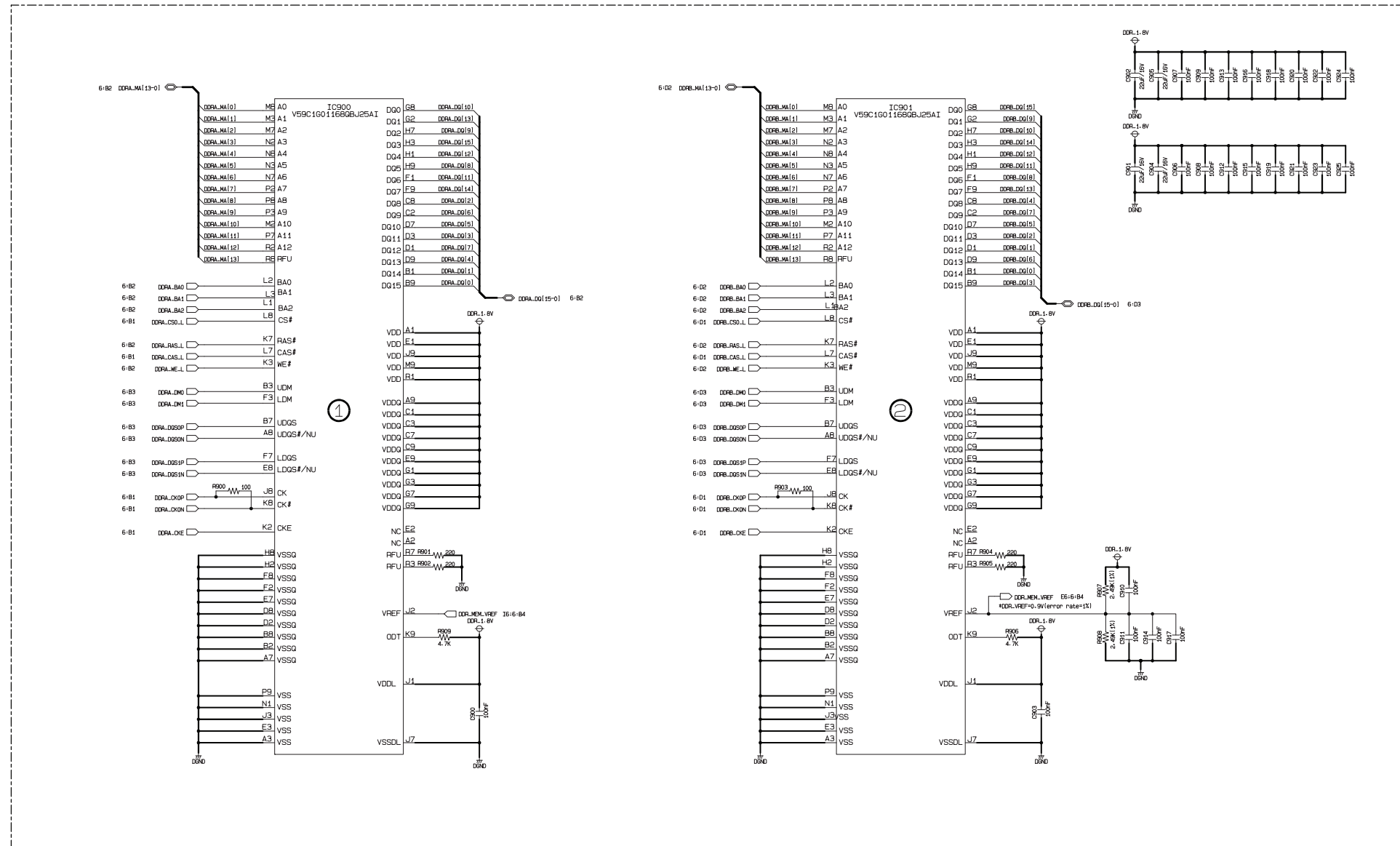

MAIN - DDR2 SDRAM
 EAX64206903_0_1.0-SD(#9)
 2012. 02. 03

11. MAIN - NOR FLASH & i-NAND CIRCUIT DIAGRAM

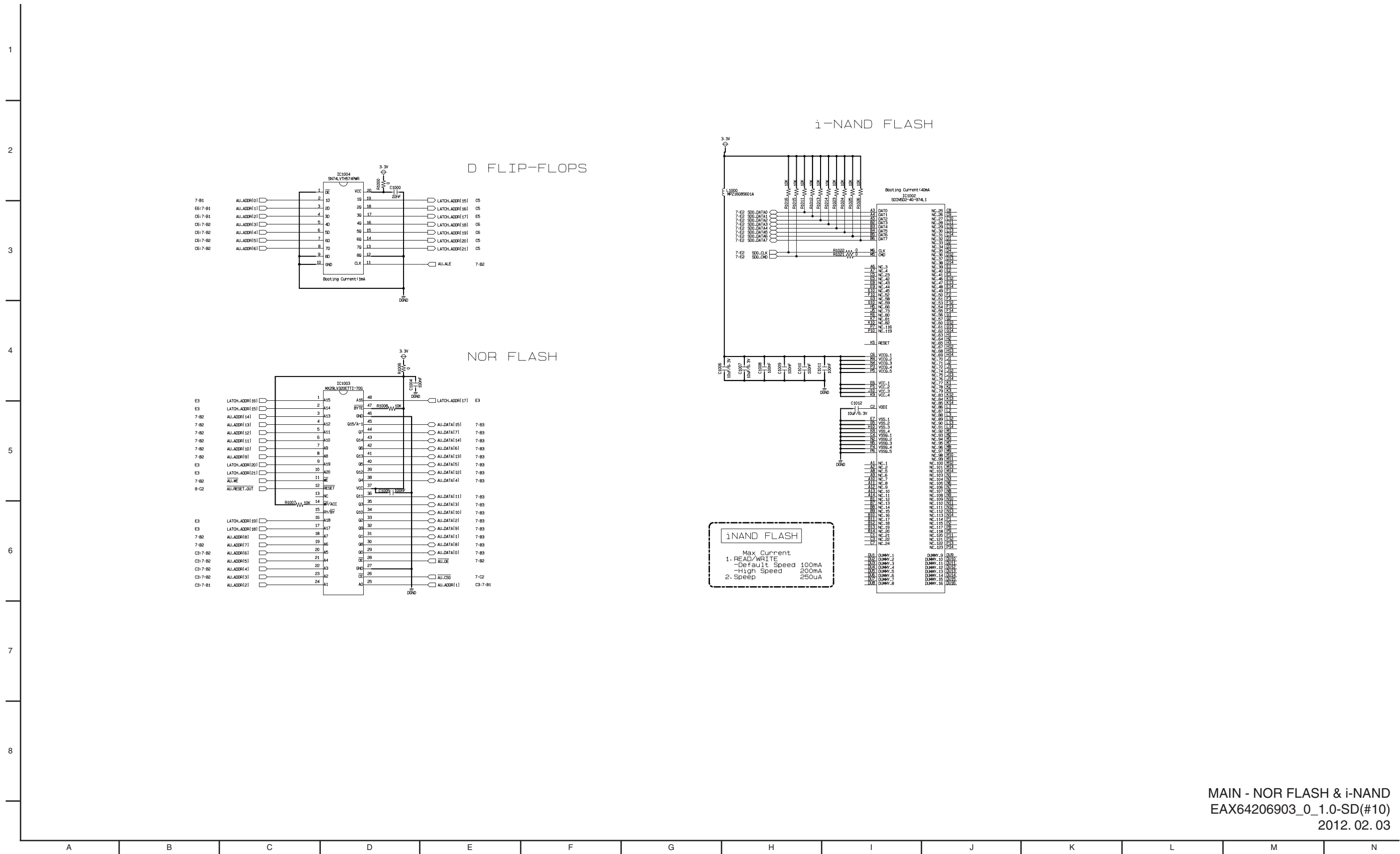

12. MAIN - VIDEO DECODER & USB CIRCUIT DIAGRAM

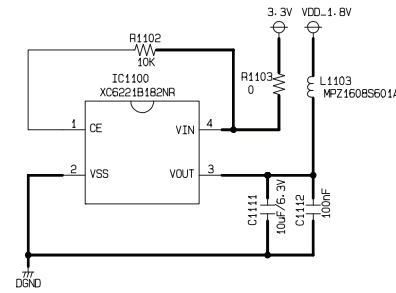

VIDEO DECODER

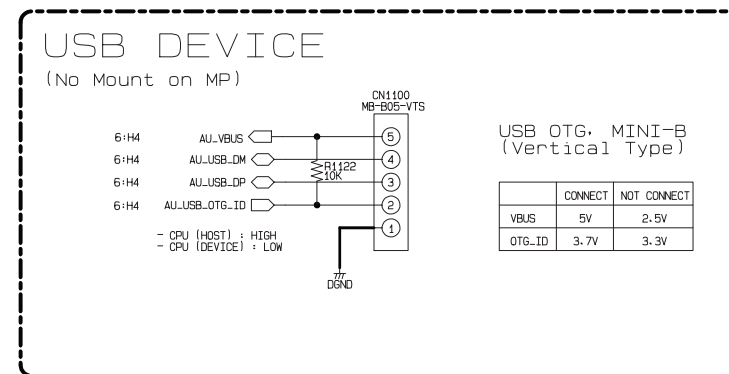
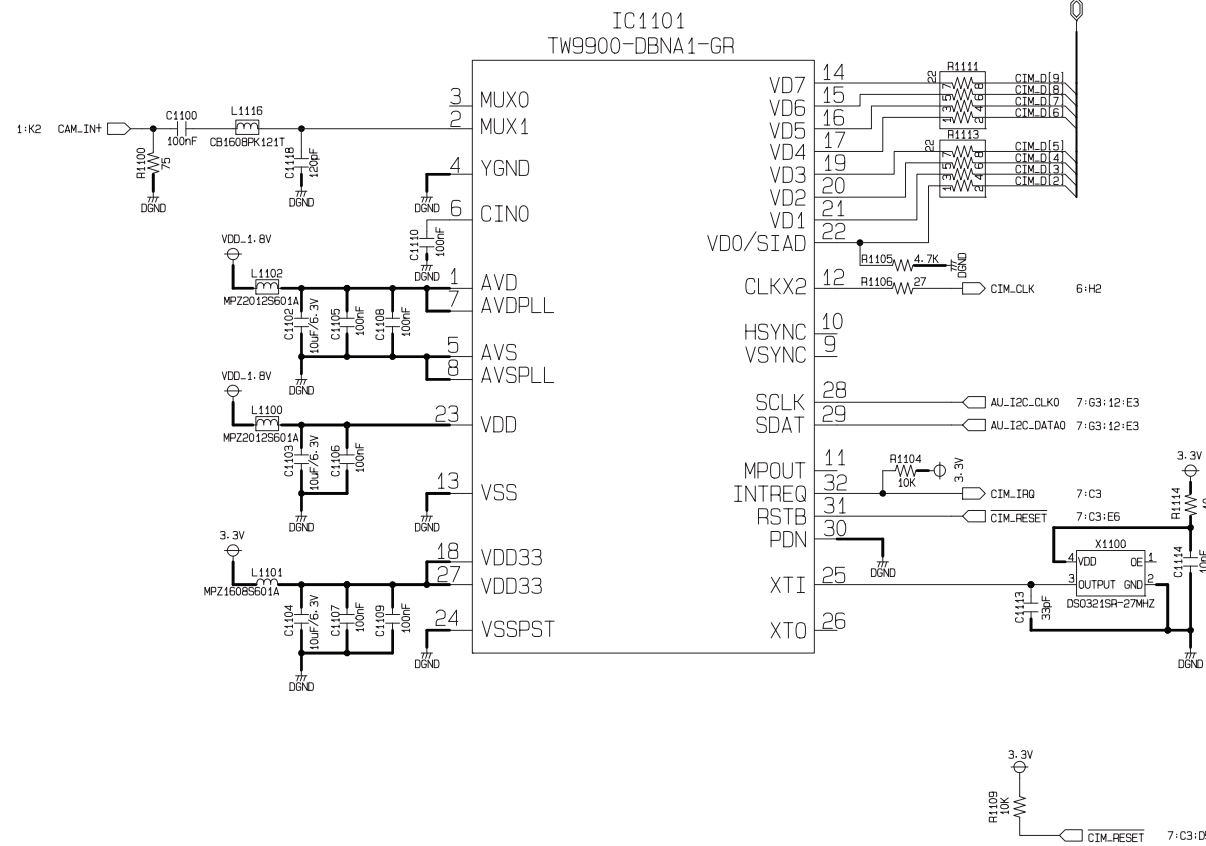
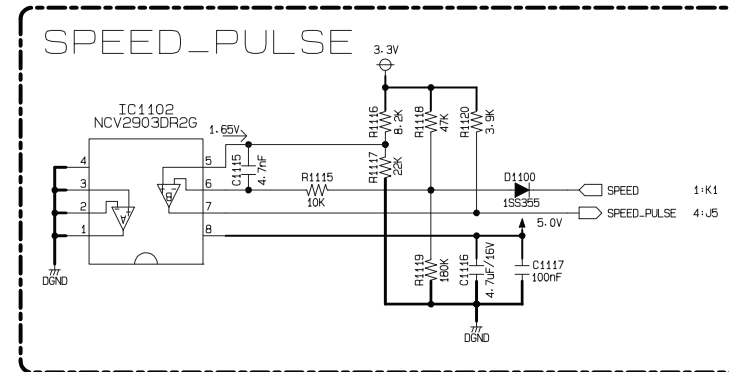

USB OTG. MINI-B
(Vertical Type)

	CONNECT	NOT CONNECT
VBUS	5V	2.5V
OTG_ID	3.7V	3.3V

13. MAIN - CONNECTOR & DEBUG CIRCUIT DIAGRAM

MAIN TO FRONT

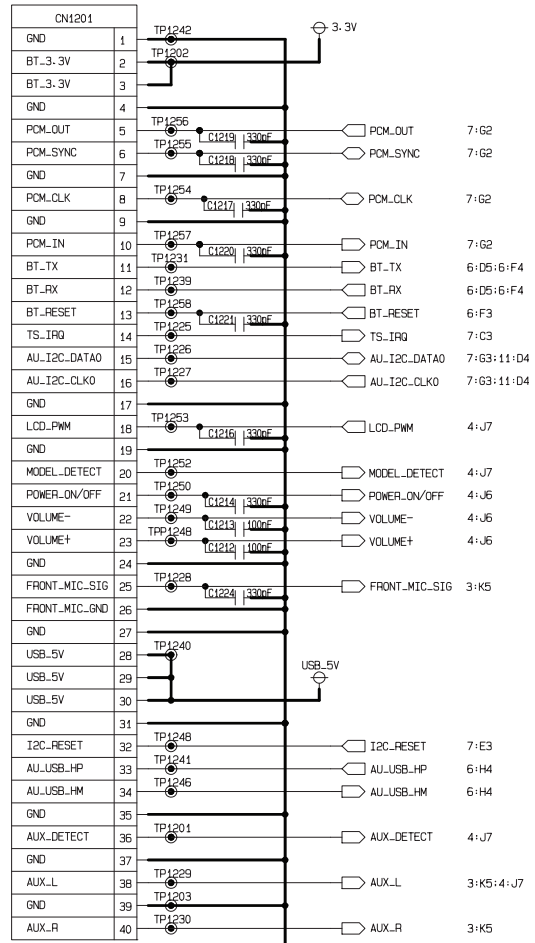
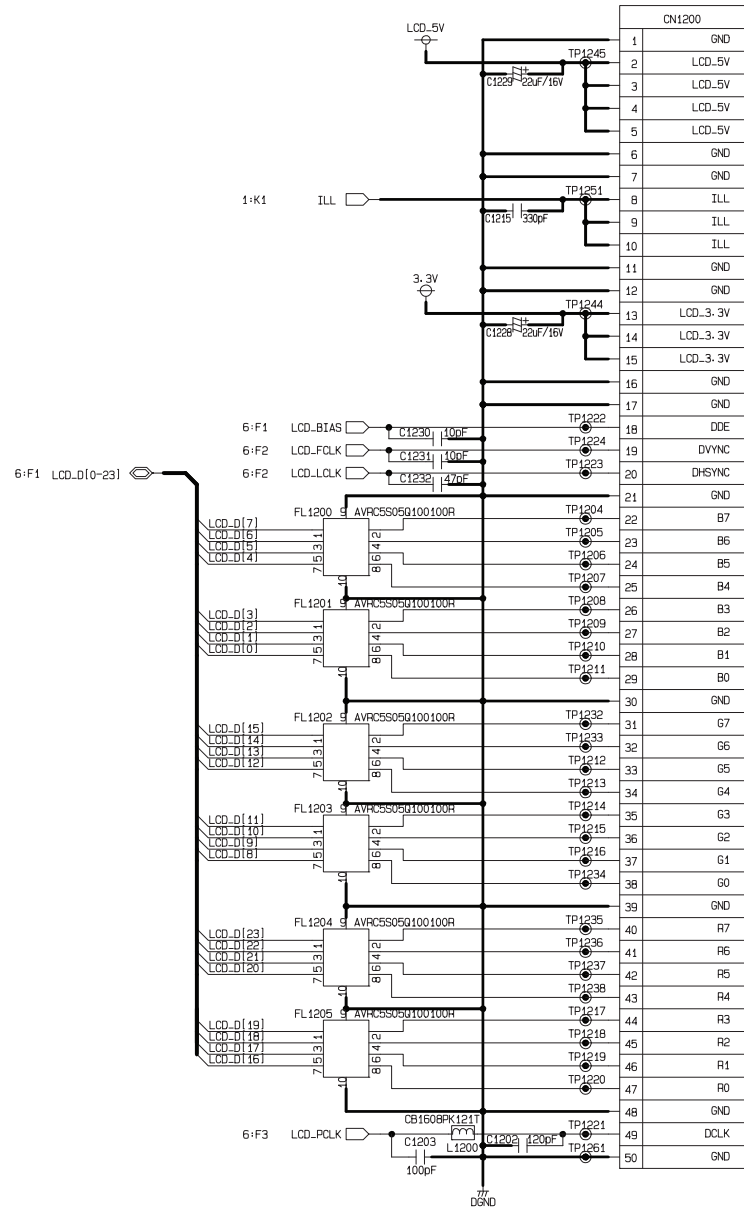

MODEL_DETECT
M0 : Low
X98 : High

DEBUG

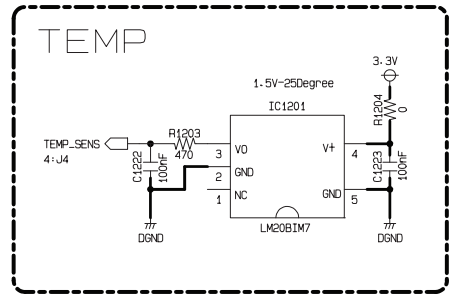
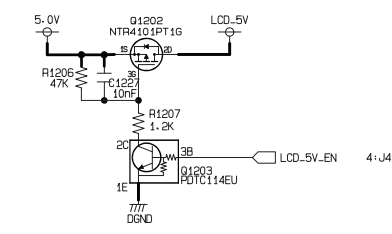
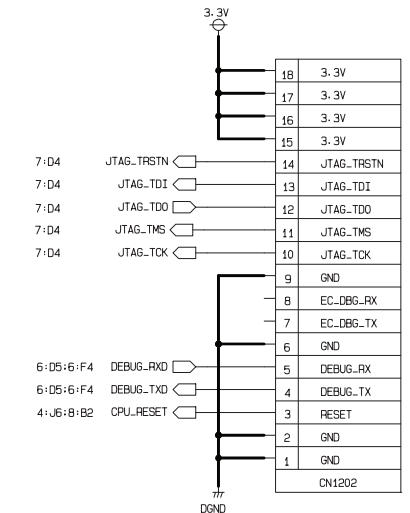

14. MAIN - GPS CIRCUIT DIAGRAM

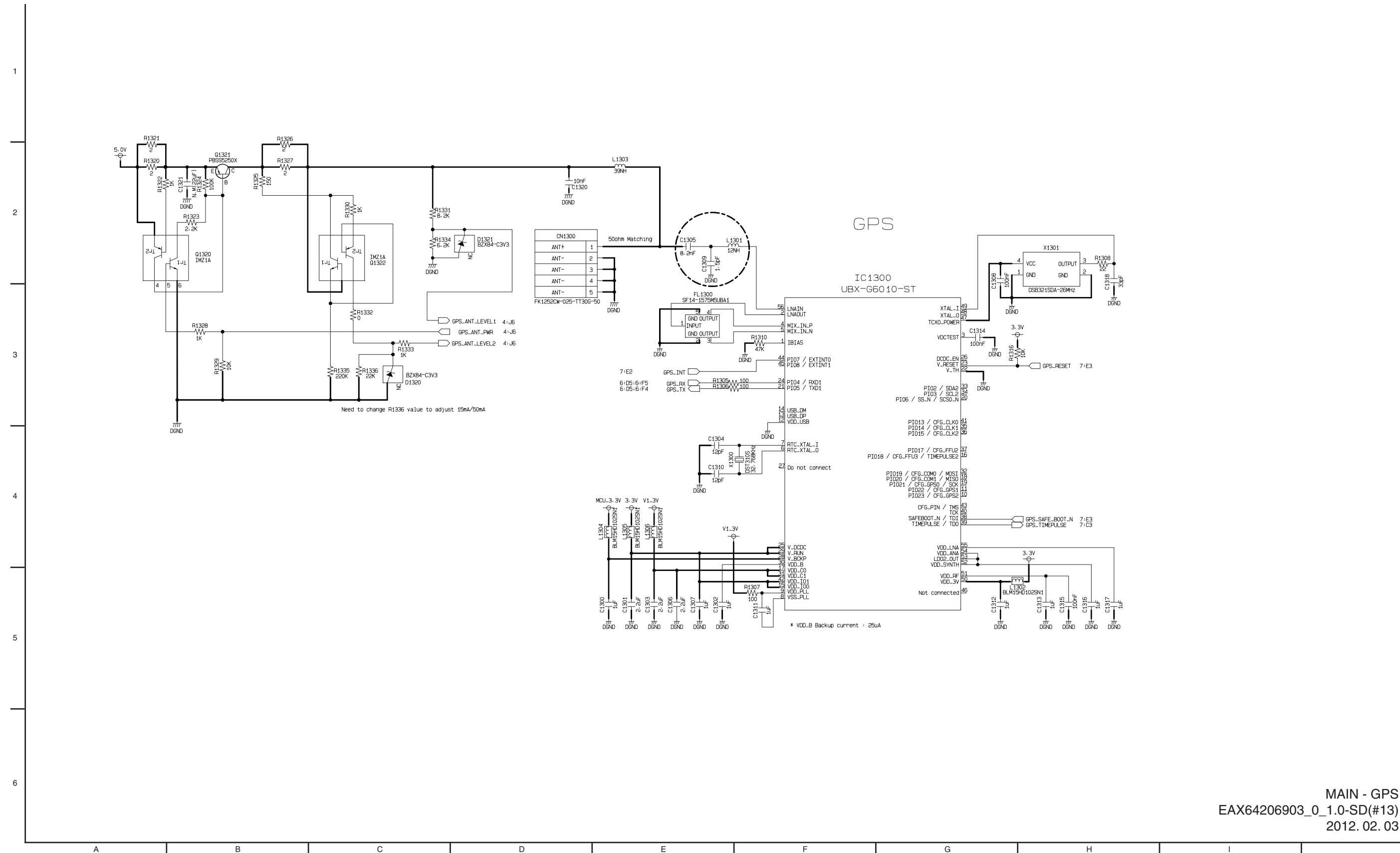

PRINTED CIRCUIT BOARD DIAGRAMS

1. FRONT P.C.BOARD

(TOP VIEW)

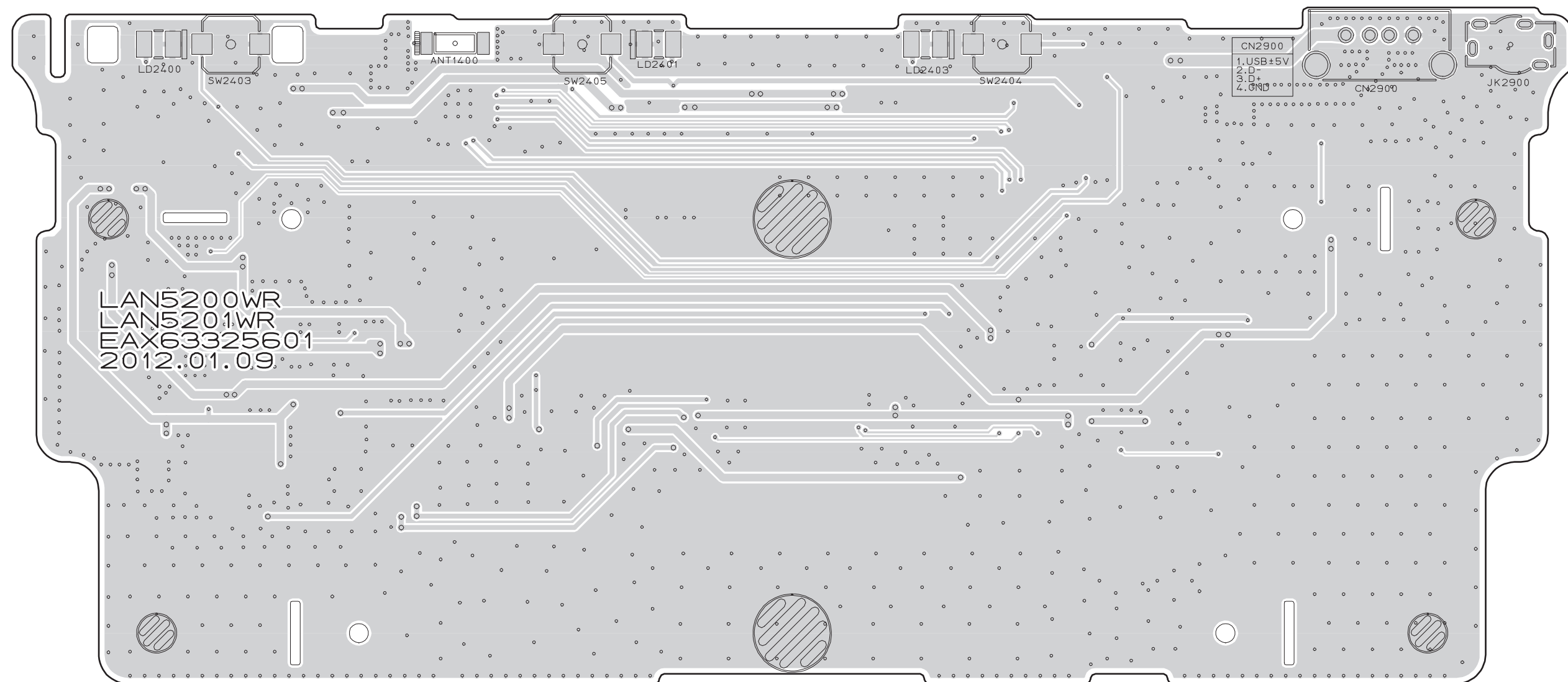

(BOTTOM VIEW)

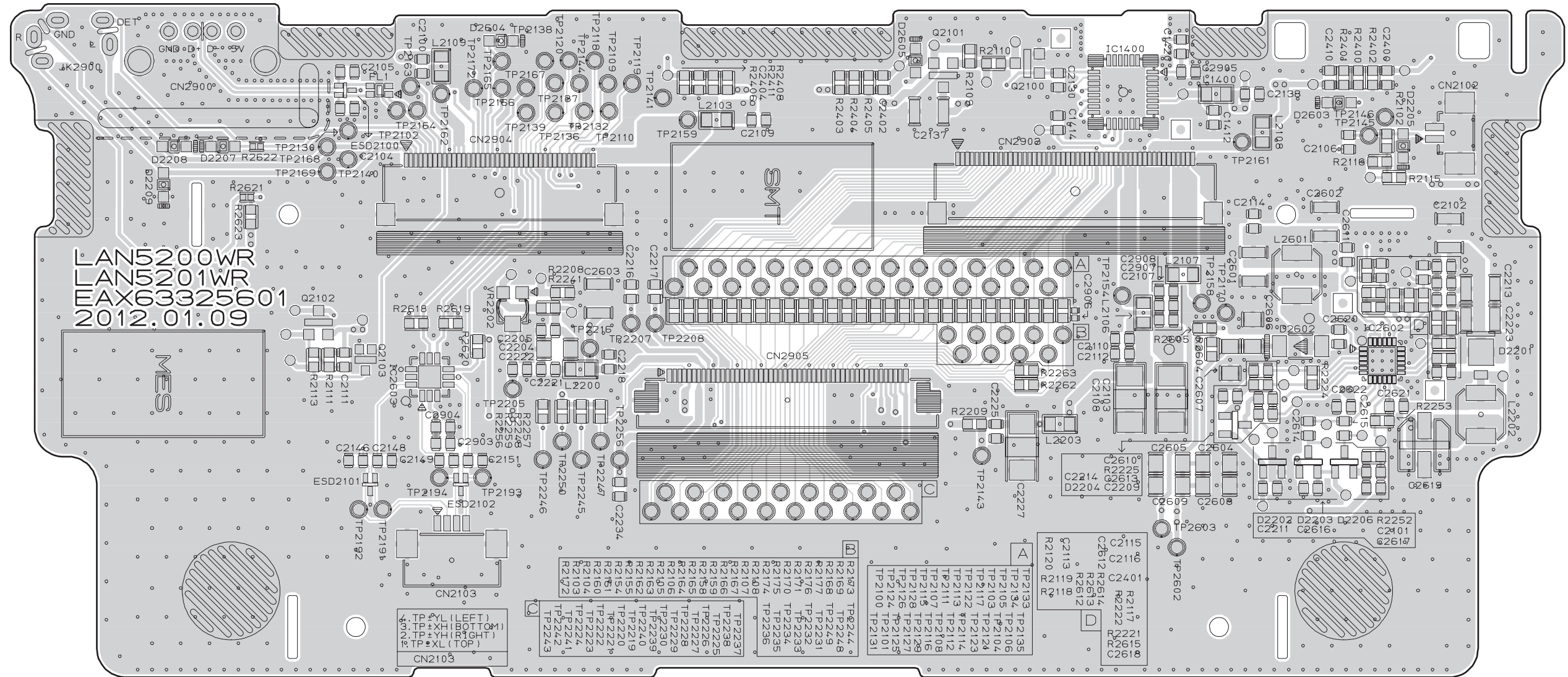

2. MAIN P.C.BOARD (TOP VIEW)

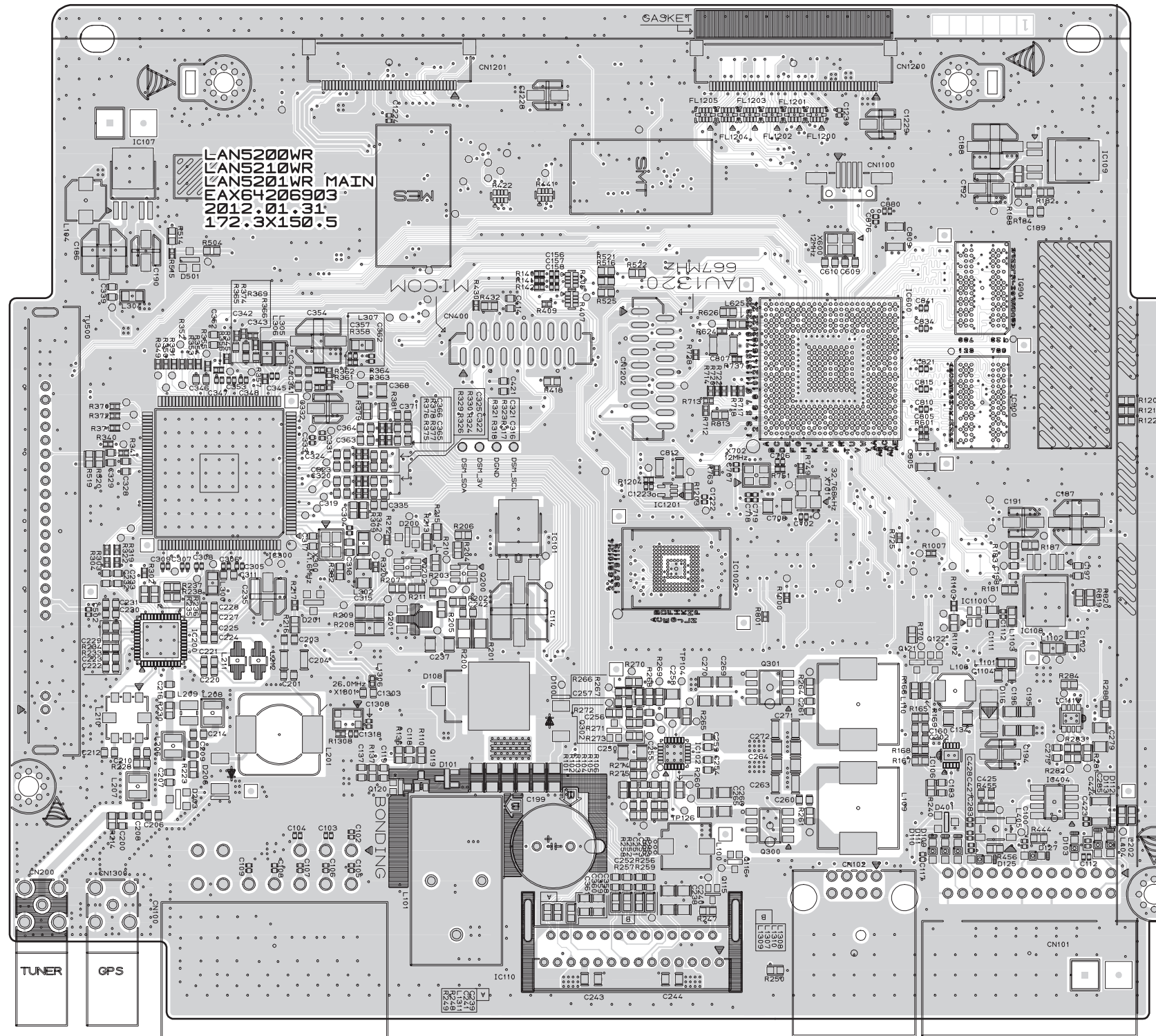

(BOTTOM VIEW)

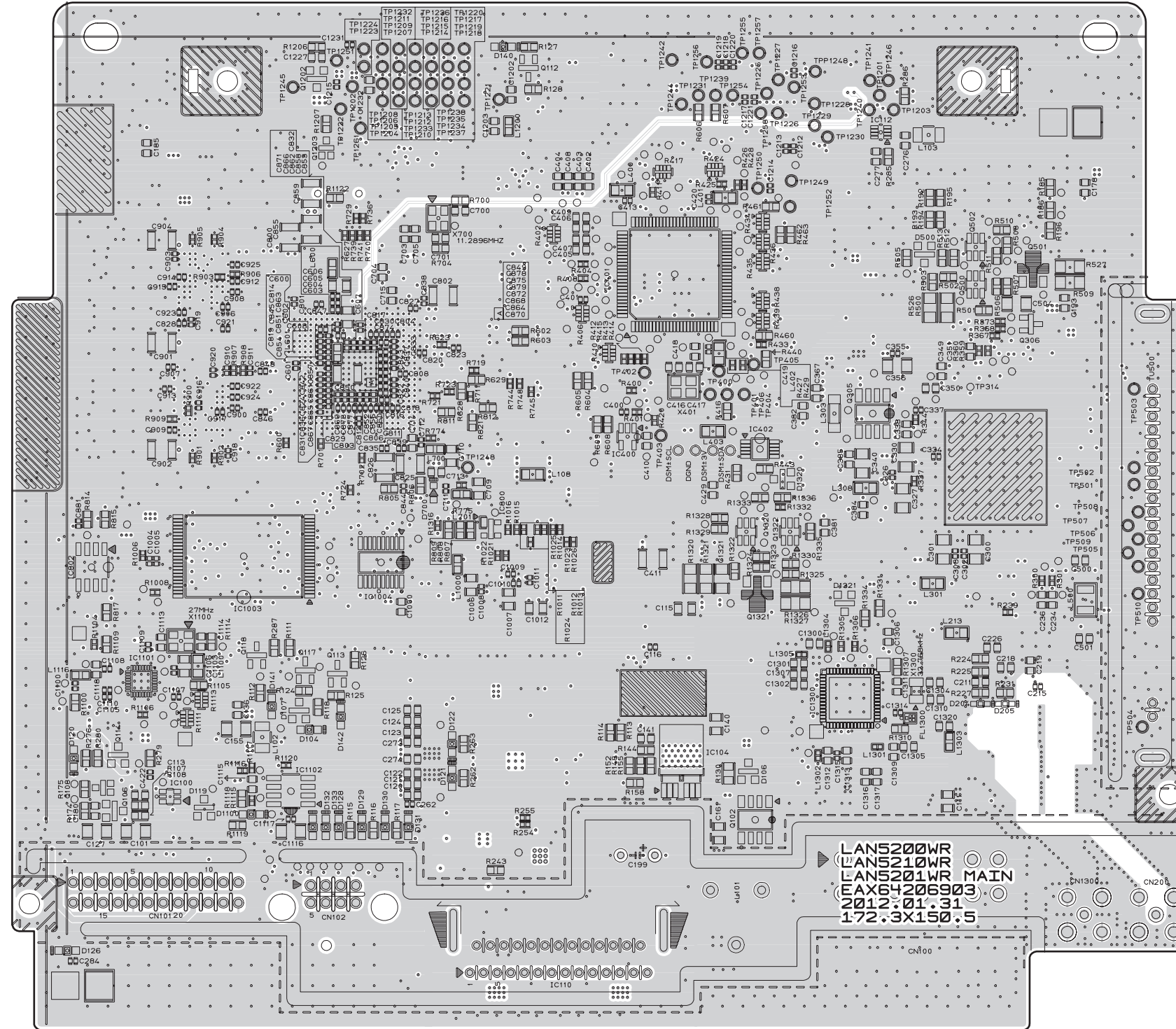

MEMO

Series of horizontal dotted lines for writing.

MEMO

Series of horizontal dotted lines for writing.

SECTION 3 EXPLODED VIEW

1. CABINET AND MAIN FRAME SECTION

