

Dry operating, single plate cable operated clutch.

Diaphragm clutch pressure plate.

Rubber hub driven clutch disc

Constant contact self centring guided thrust ball bearing.

Automatic wear compensation

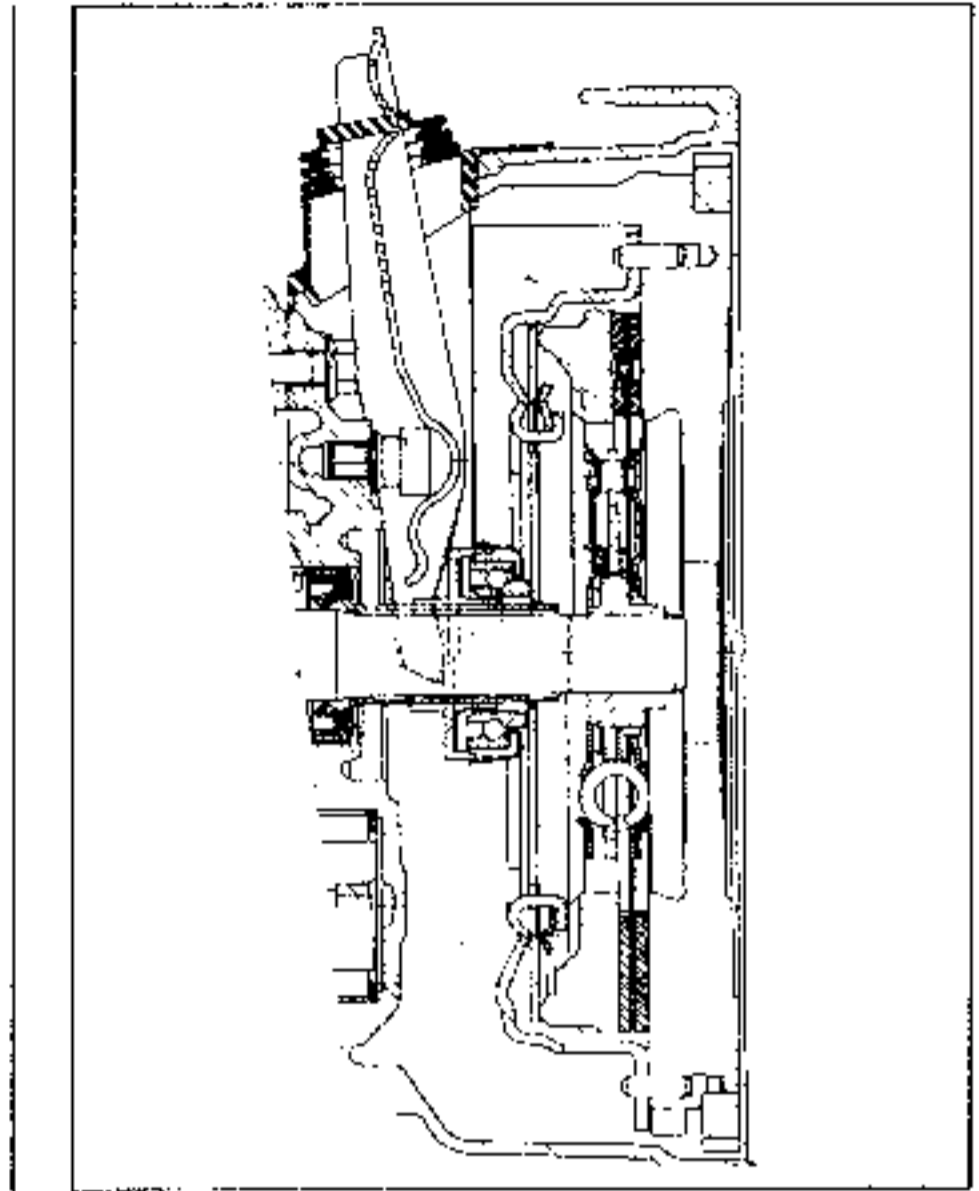

### Exploded view

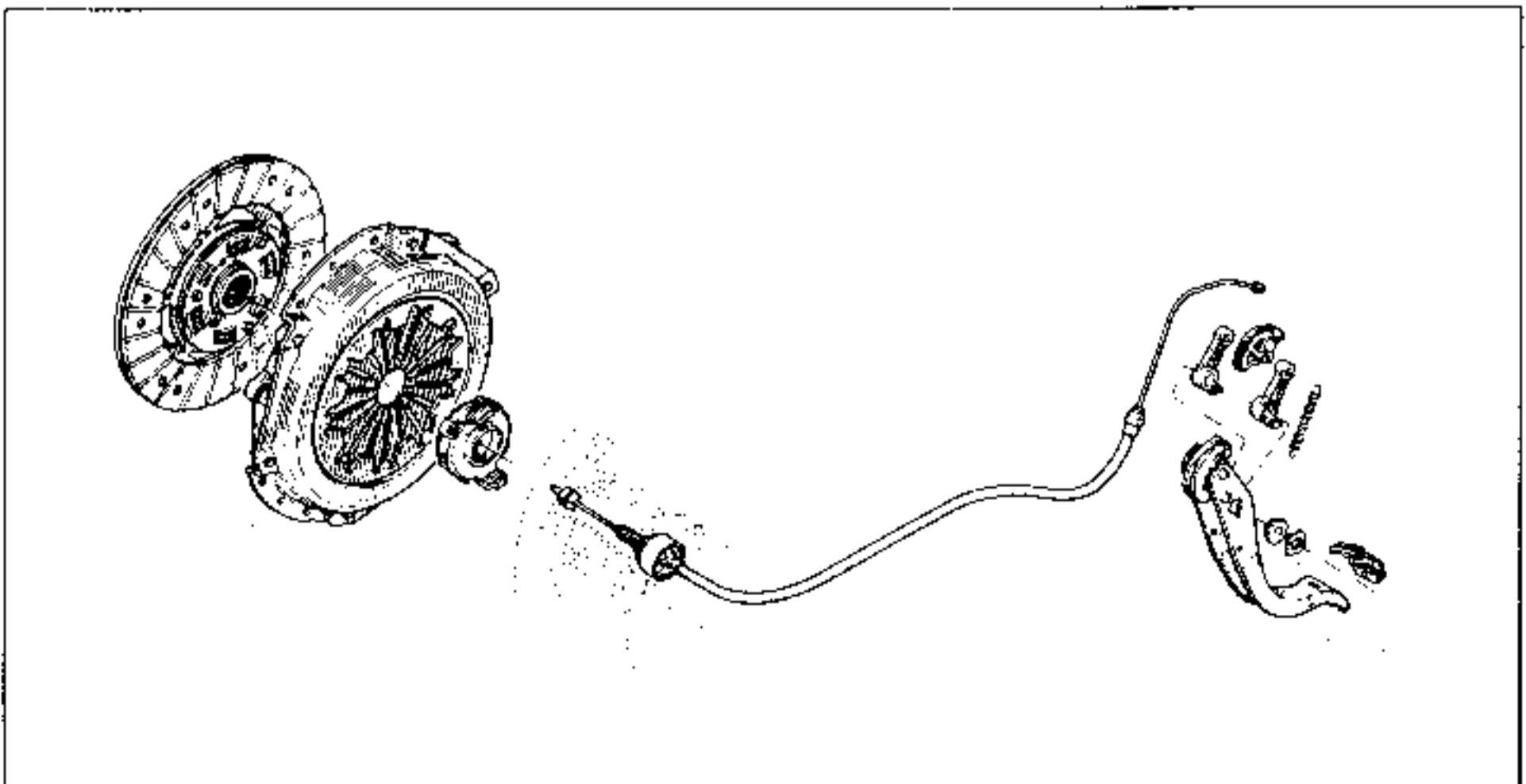

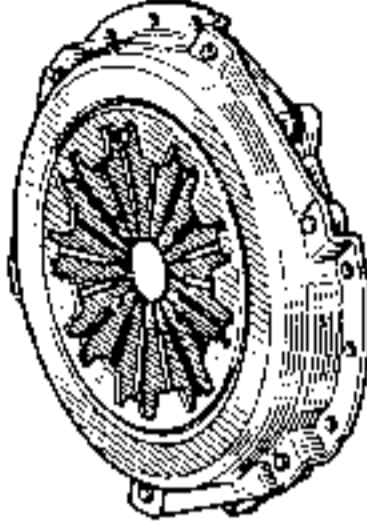
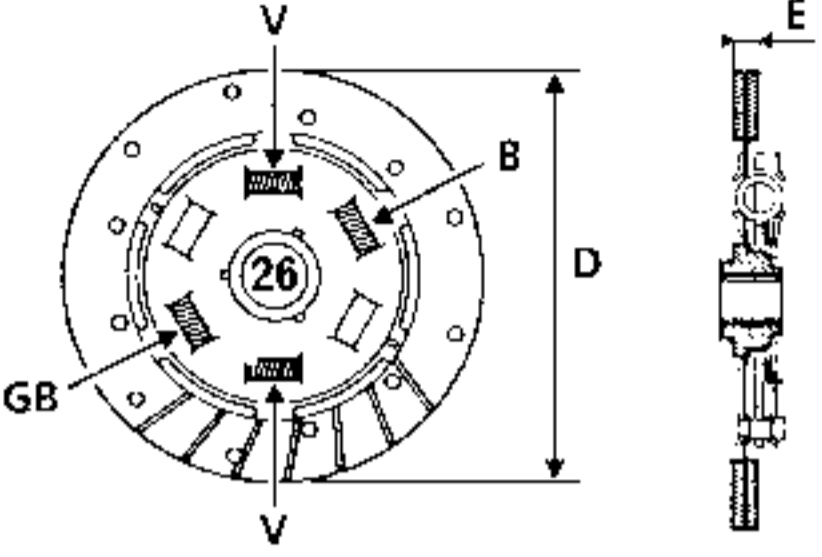
VEHICLE TYPE	ENGINE TYPE	MECHANISM	DISC
C063	C3G	 <p style="text-align: center;">B5 873 S    90 693-4 R</p> <p style="text-align: center;"><b>160 CPH 2750</b></p>	 <p style="text-align: right;">76 906 R</p> <p style="text-align: center;"> <b>26 splines</b>      V = Green  E = 7,4 mm      B = White  D = 160 mm      GB = Grey Blue </p>

Type	Packaging	Part No.	Component
MOLYKOTE BR2	1 kg tin	77 01 421 145	Right hand sun wheel splines Fork pivot Thrust pad guide Fork pads  Clutch
CAF 4/60 THIXO	100 g tube	77 01 404 452	Ends of drive shaft roll pins
LOCTITE 518	24 ml syringe	77 01 421 162	Housing assembly faces

KEY

Fault noted

Test

Operation to be carried out

The clutch slips, the engine seems to race

Check the automatic wear compensation system

INCORRECT

CORRECT

Toothed quadrant broken or spring broken

Clutch worn or greasy

INCORRECT

CORRECT

INCORRECT

Replace faulty parts

Check the rubber mounting (removed)

Replace the clutch

Repair the leak

INCORRECT

Replace the rubber mounting

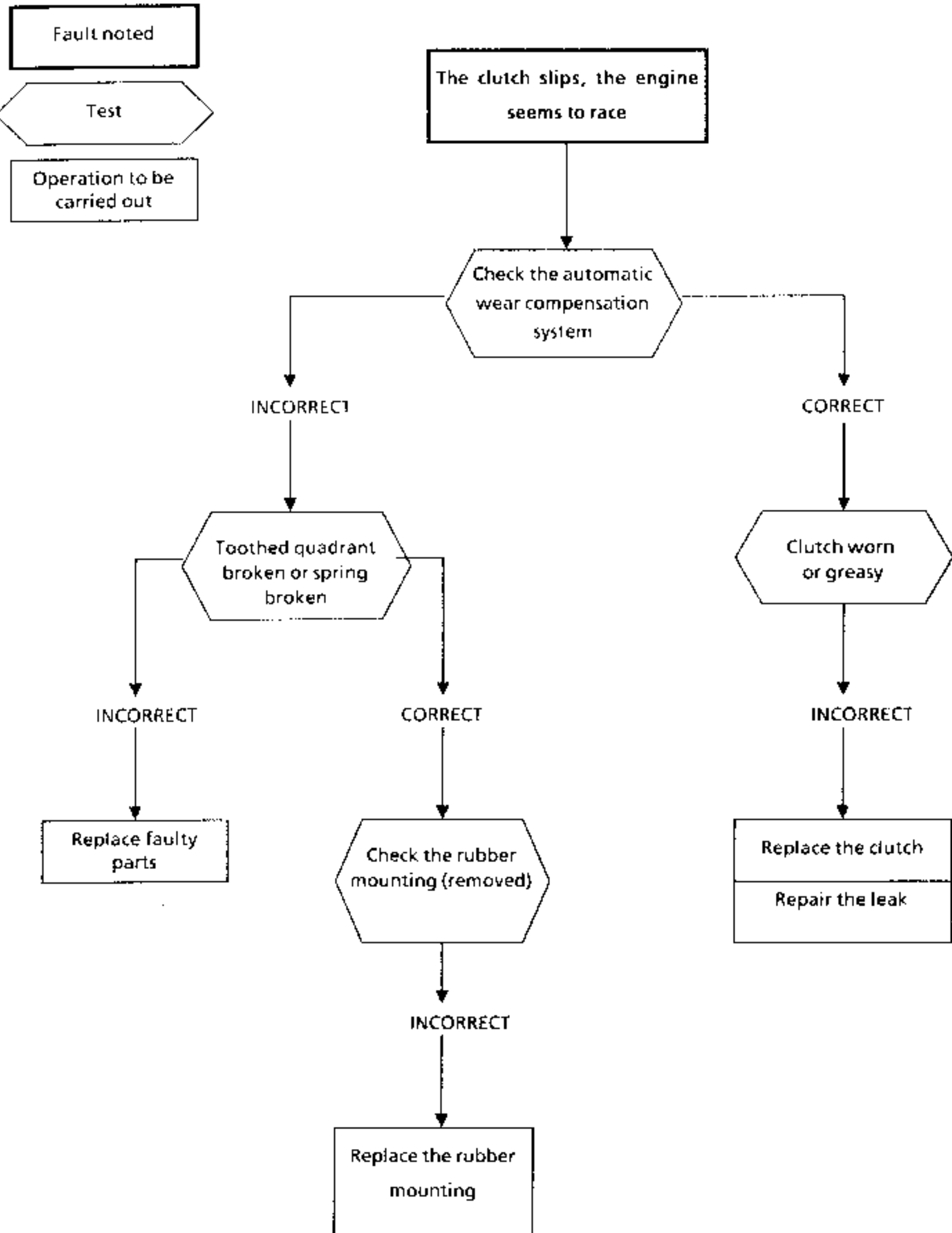

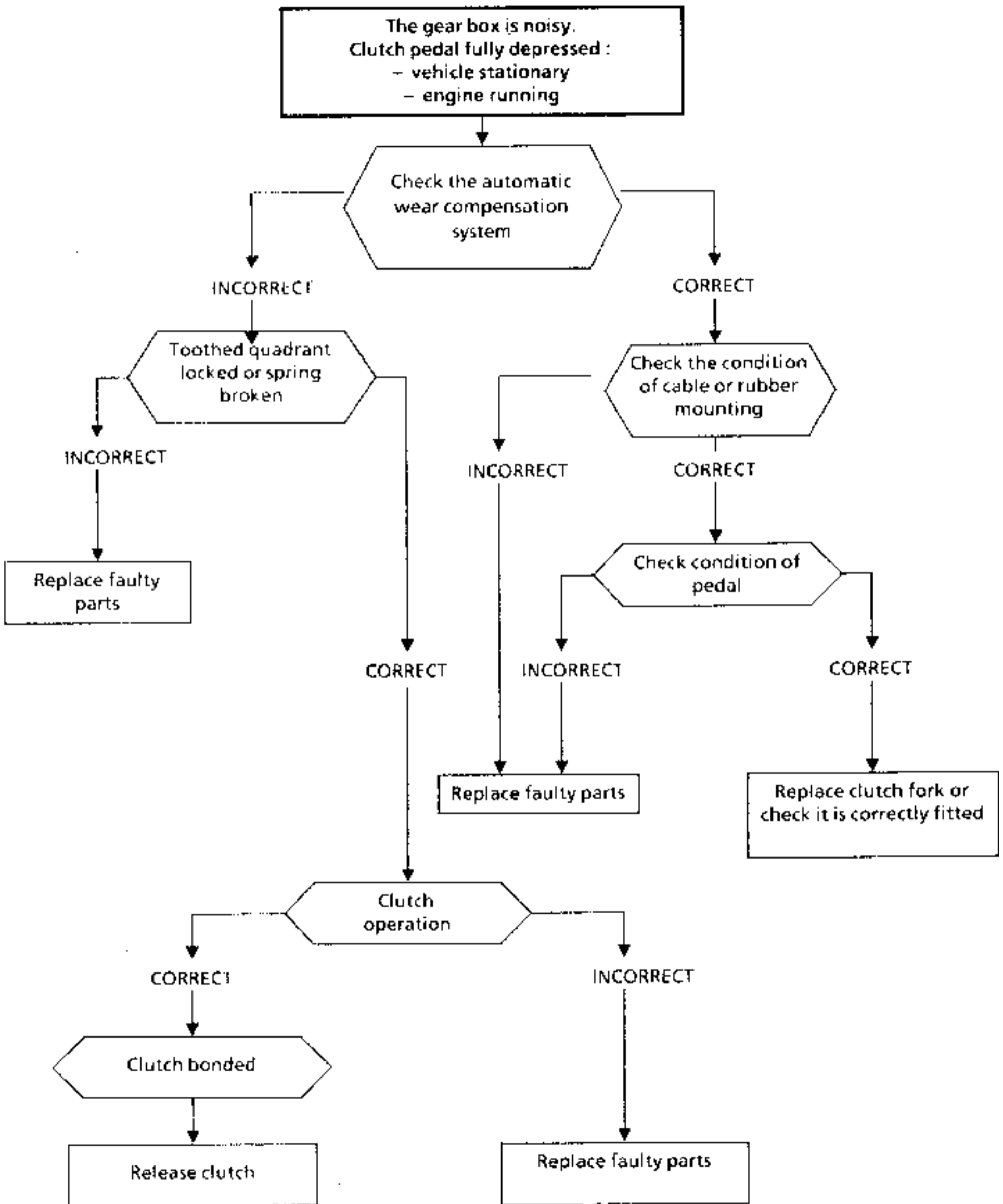

This is a rare occurrence but may happen after the vehicle has been left stationary for a long period (several days)

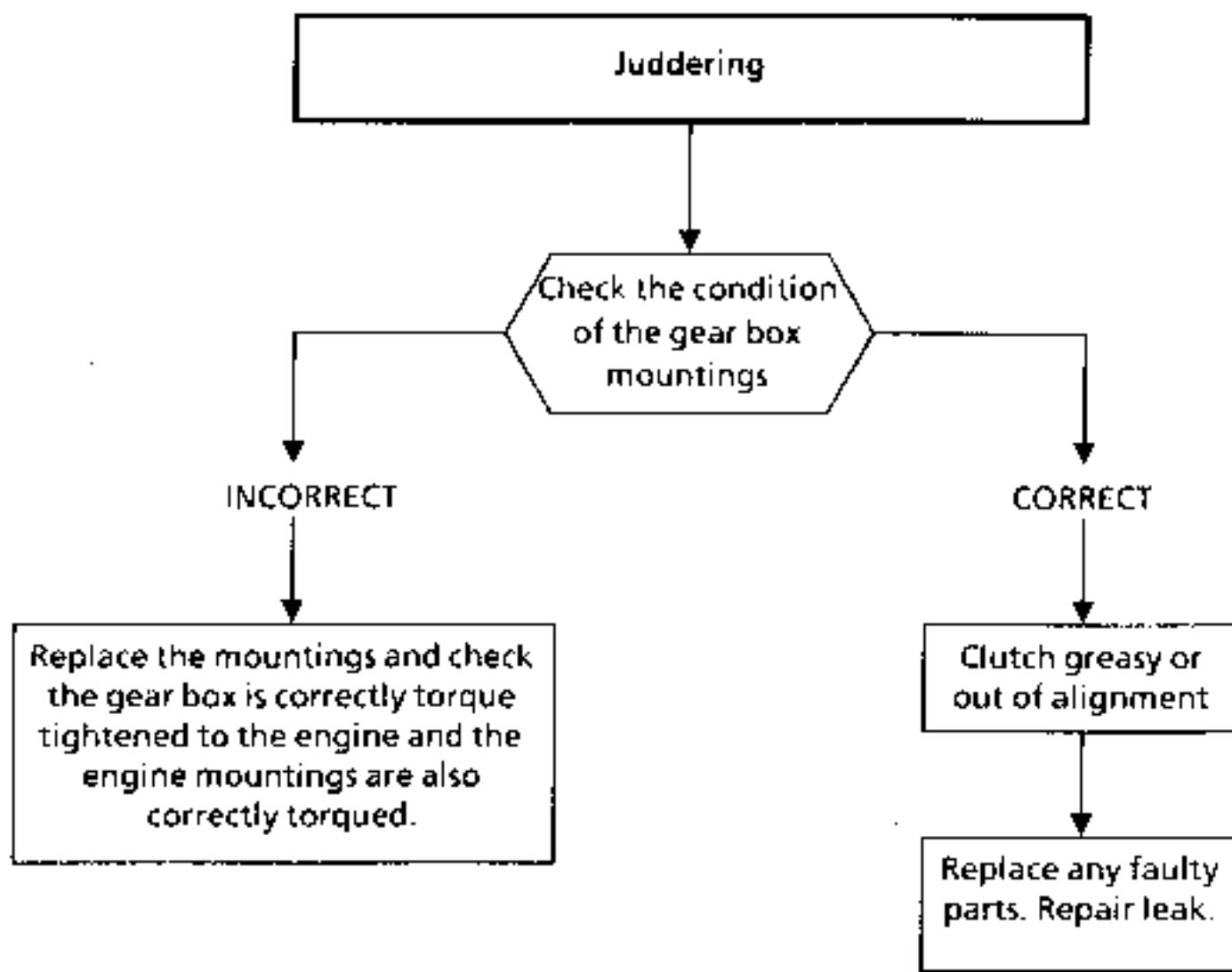
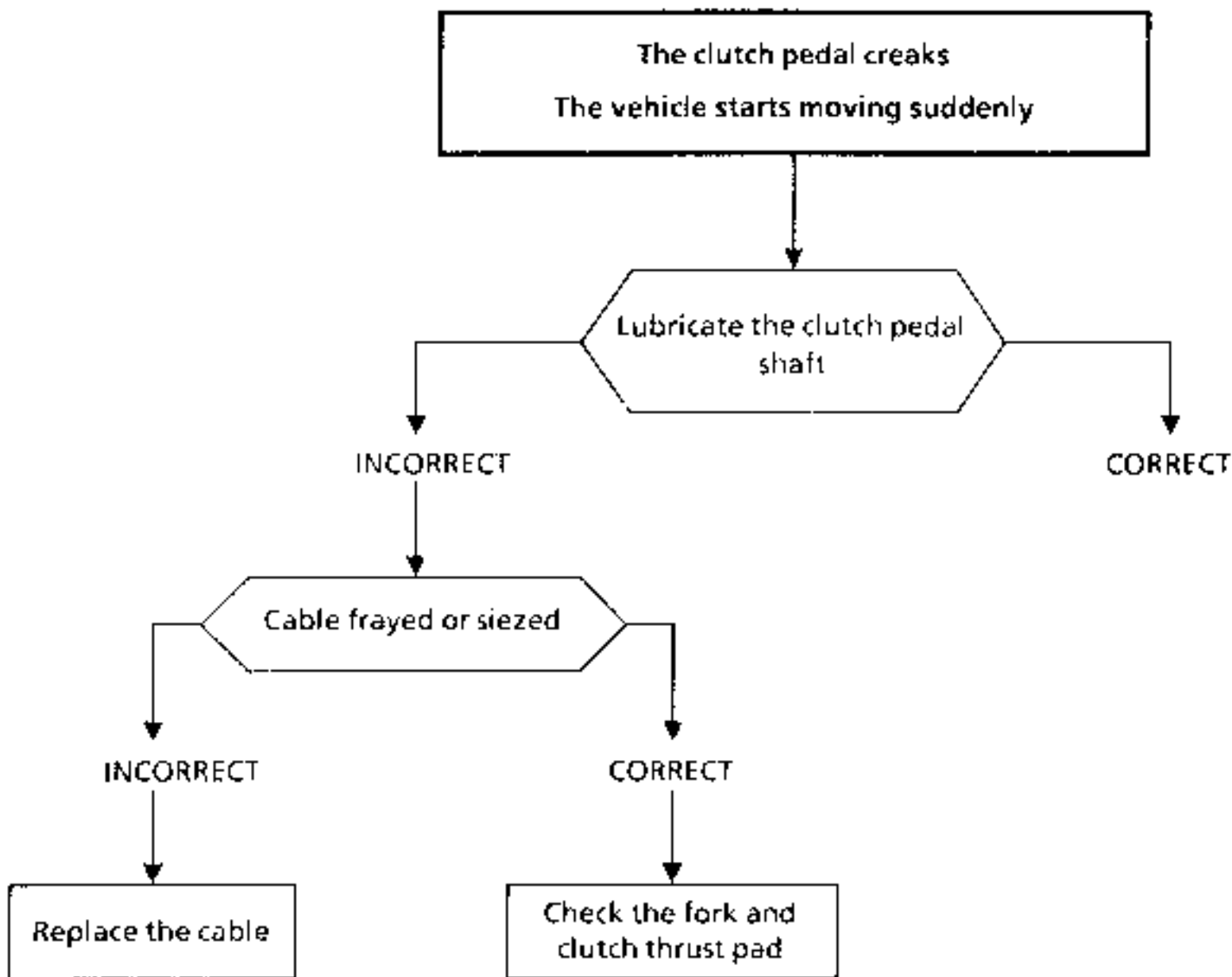

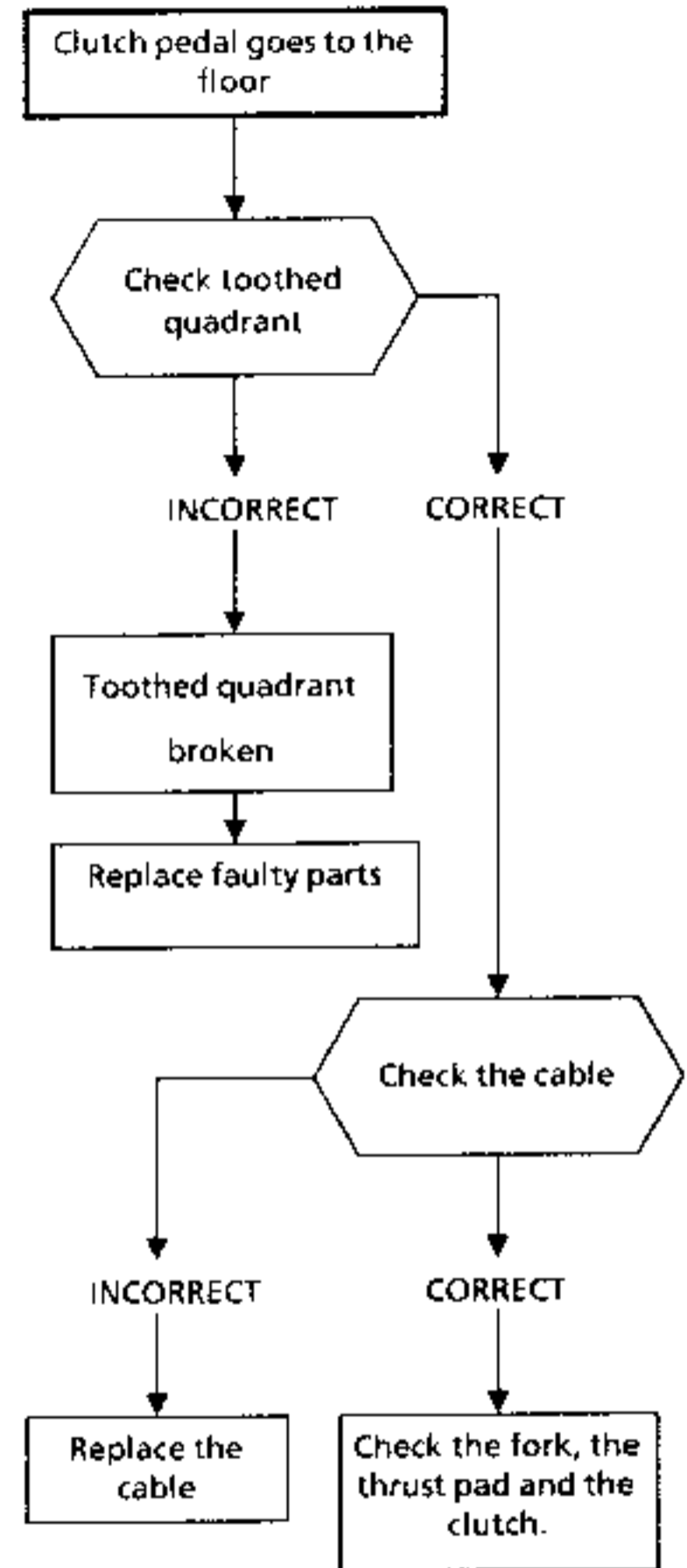
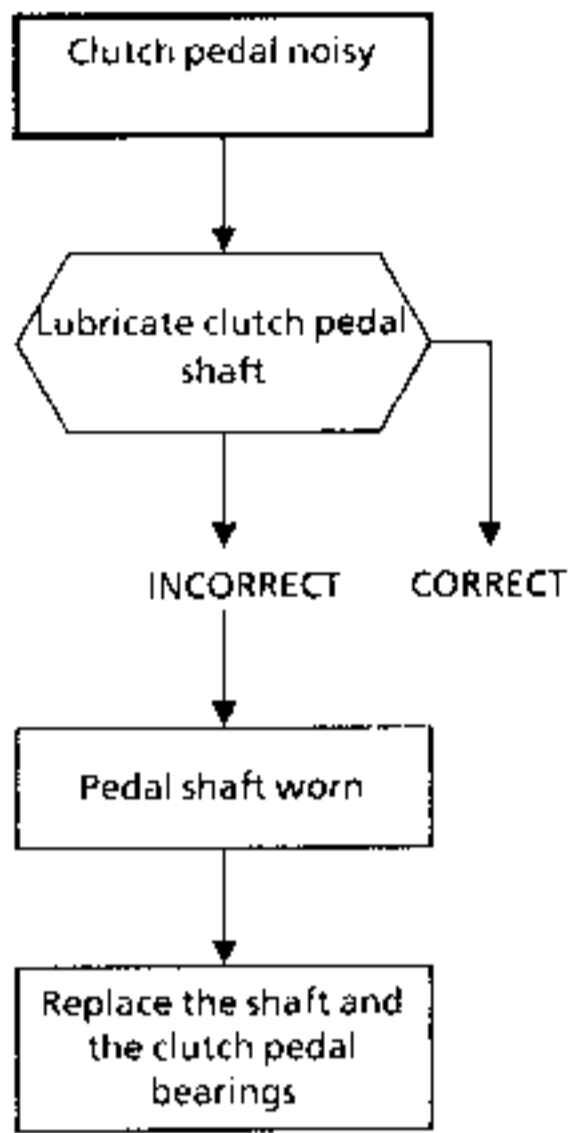
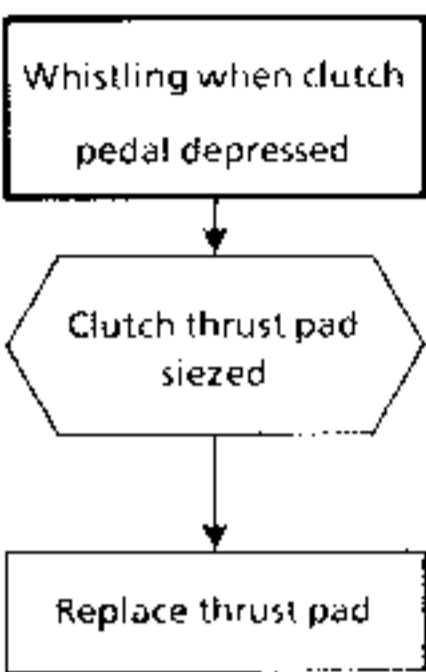

## REPLACEMENT

This operation is carried out after uncoupling the gear box from the engine.

SPECIAL TOOLING REQUIRED	
Mot. 582	Locking segment

TIGHTENING TORQUES (in daN.m)	
Mechanism mounting bolt $\varnothing 7$	2,5

## REMOVAL

Fit the locking segment **Mot. 582**.

Remove the mechanism mounting bolts and remove the mechanism as well as the clutch disc

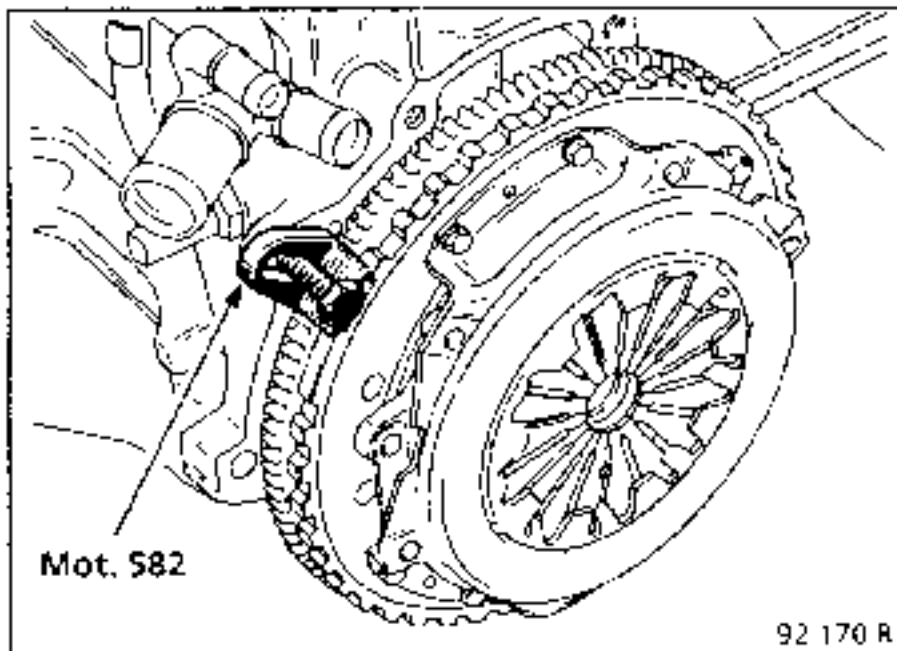

### Visually check:

- that the engine flywheel is not scored,
- engine flywheel wear,
- the condition of the starter ring gear,
- the sealing of the crankshaft lip seal and the guide tube on the gear box.

Replace any faulty parts and clean the clutch shaft splines.



**ESSENTIAL PRECAUTIONS WHEN REPAIRING THE CLUTCH**

To improve clutch disc slide, the disc hubs are now nickel coated.

Clean the clutch shaft splines and refit the assembly without using a lubricant.

Fit the disc into place : offset side (A) of the hub should be on the gear box side.

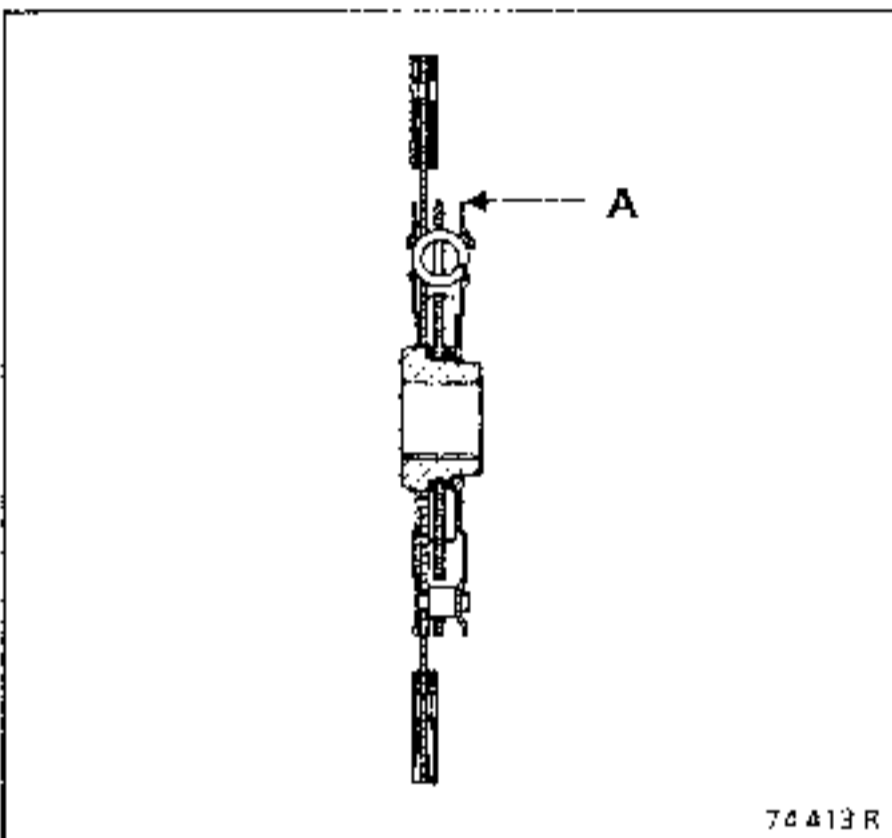

74413 R

Use the plastic centring tool in the kit to refit the disc

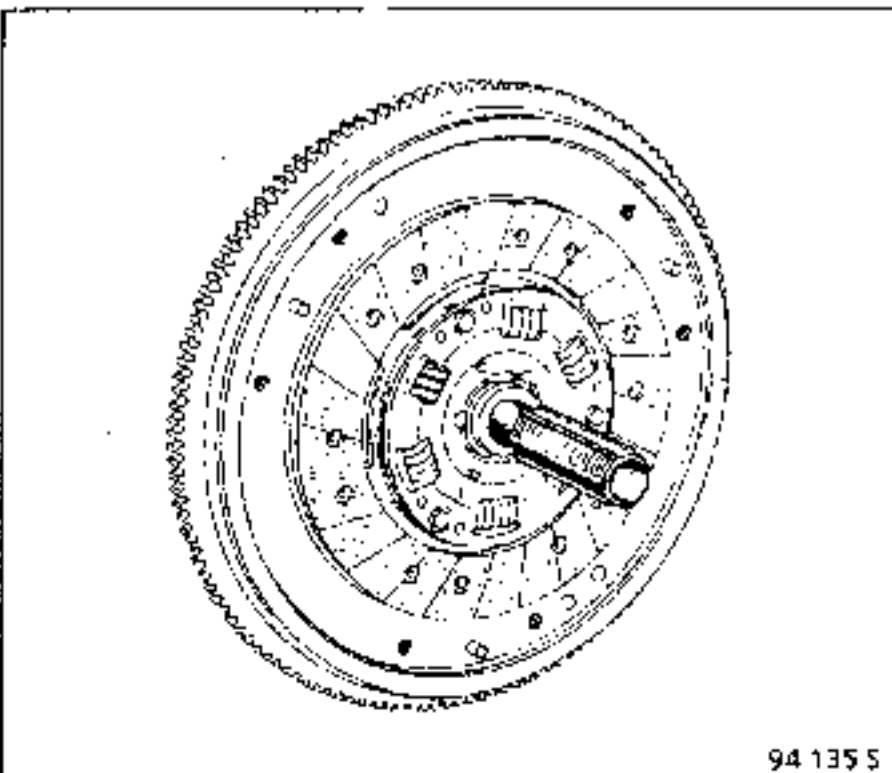

94135 S

Refit the mechanism

Tighten the mechanism mounting bolts slowly, then tighten them to the recommended torque

Remove the locking segment **Mot. 582**.

Apply **MOLYKOTE BR2** to :

- the thrust pad bore,
- the guide tube,
- the fork pads,
- the pivot.

After re-fitting the gear box, reset the toothed quadrant and check the wear compensation system is operating correctly.

Check the fork travel It should be:

$$X = 17 \text{ to } 18 \text{ mm.}$$

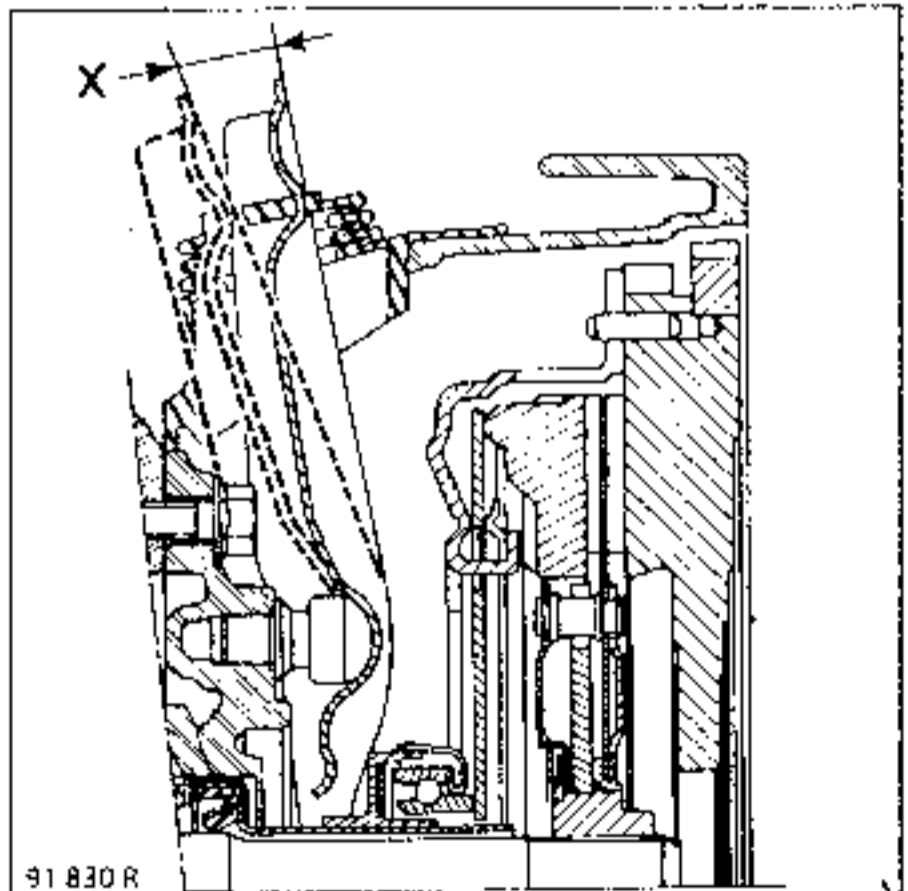

91830 R

## REPLACEMENT

This operation is carried out after uncoupling the gear box from the engine.

## REMOVAL

Remove:

- the thrust pad by tilting the fork,
- the rubber protector and pull the fork towards the centre of the clutch bellhousing.

## REFITTING

Coat the guide tube surface and the fork pads with **MOLYKOTE BR2**.

Refit the fork and the rubber protector.

Fit the guide tube on the thrust pad ensuring lug (A) is correctly located in the fork

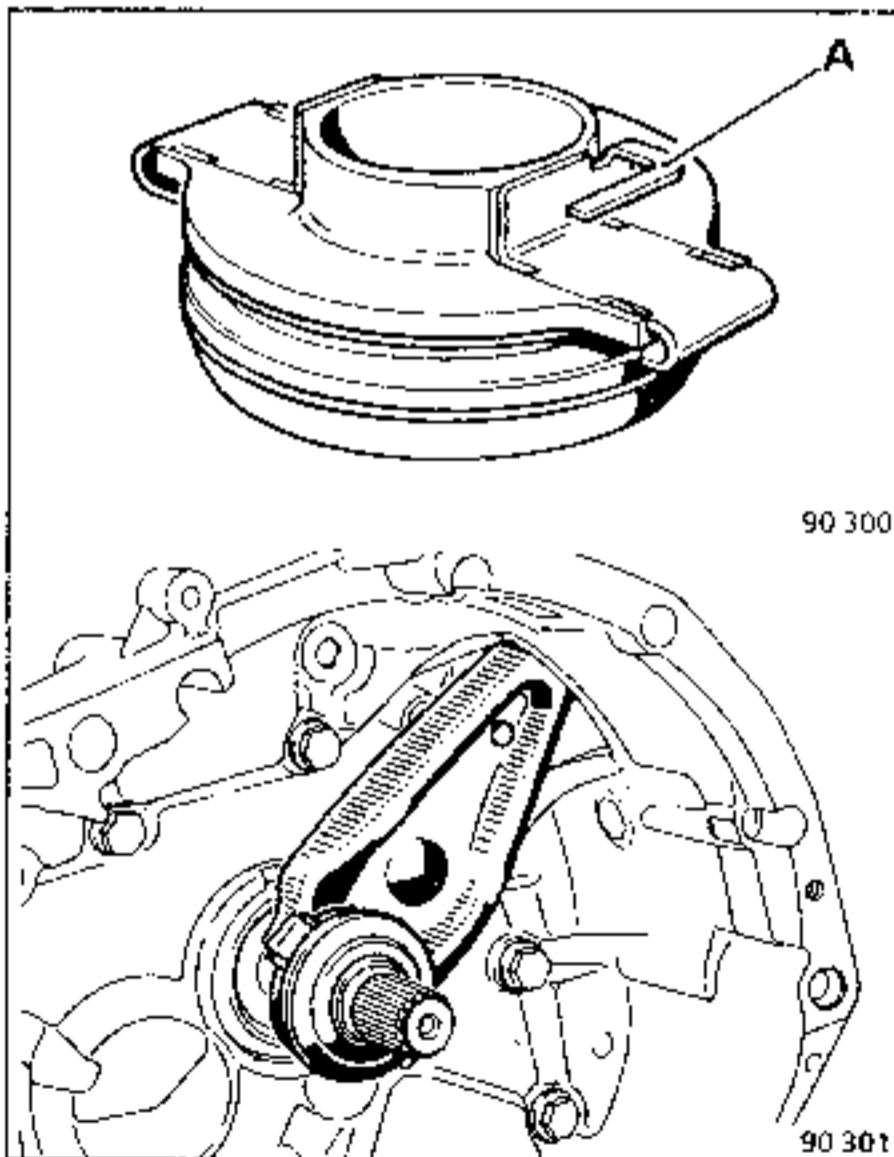

Ensure the assembly slides correctly.

**NOTE :** after an operation which does not require the gear box to be removed or after fitting the gear box **DO NOT LIFT** the fork as it may be separated from the lug (A) on the thrust pad.

**REPLACEMENT**

This operation is carried out after removing the gear box and separating the mechanism housing from the clutch bellhousing.

Refer to gear box repair manual "B.V. JB".

**NOTE:**

Thrust pad guide tubes are supplied with a lip seal protector already fitted to avoid damaging the seal when the part is fitted onto the clutch shaft splines.

Do not remove this protector during or after fitting the thrust pad guide tube onto the housing.

When the primary shaft is refitted, the protector is removed.

SPECIAL TOOLING REQUIRED	
B.Vi. 28-01	Extractor body
B.Vi. 31-01	Set of pins for removing and refitting roll pins $\varnothing$ 5 mm
B.Vi. 1170	5th gear hub extractor
B.Vi. 1007	Claws for B.Vi. 28-01
B.Vi. 945	Mandrel for fitting differential seal.

TIGHTENING TORQUES (in daN.m)	
Bellhousing bolts	2,5
Primary shaft nut	13,5
Secondary shaft bolt	8

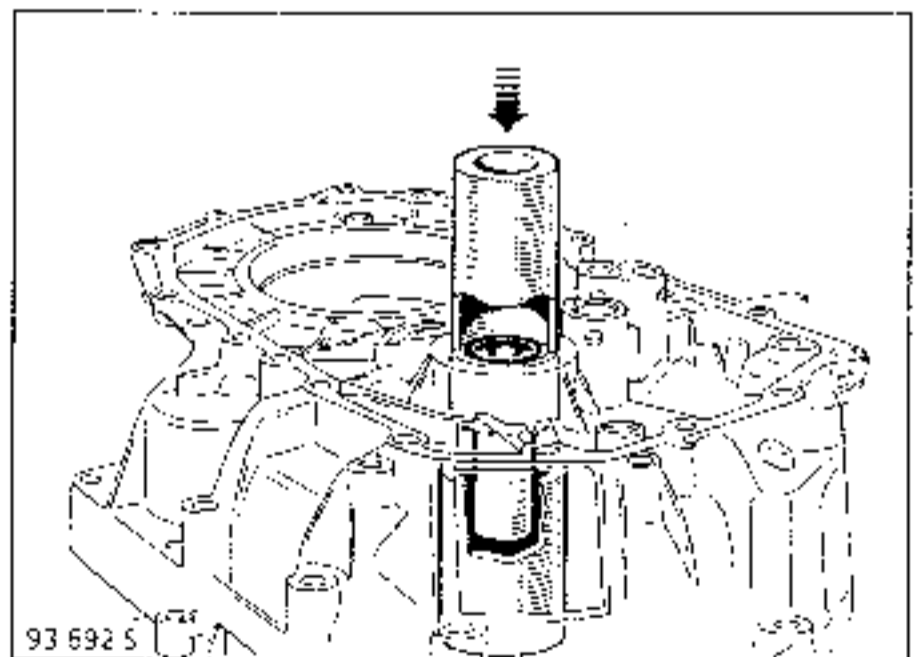

**REFITTING**

The guide tubes are supplied with a lip seal protector already fitted to avoid damaging the seal when the part is fitted onto the clutch shaft splines.

Coat the walls of the bore with **MOLYKOTE BR2**.

**REMOVAL**

The lip seal and the clutch shaft bearing (primary) are joined to the thrust pad guide tube. Lubrication is via an opening connecting to the clutch bellhousing bore.

Resting the bellhousing on a tube of internal diameter 48 mm and external diameter 55 mm, extract the guide tube on the press with the aid of a tube of external diameter 45 mm.

Align the bearing lubrication hole (A) in the guide tube opposite the hole in the clutch bellhousing (B).

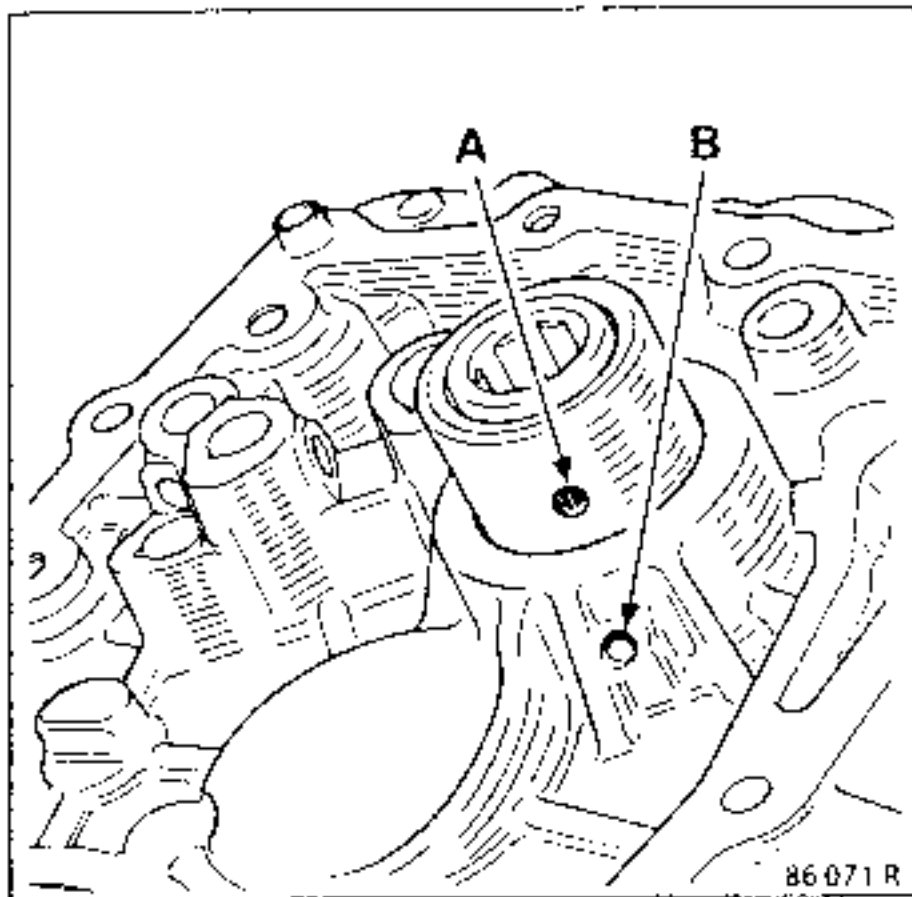

With the bellhousing resting on the tube, use the press to fit the guide tube until it comes into contact with the inner face of the bellhousing. Use tool B.Vi. 945.

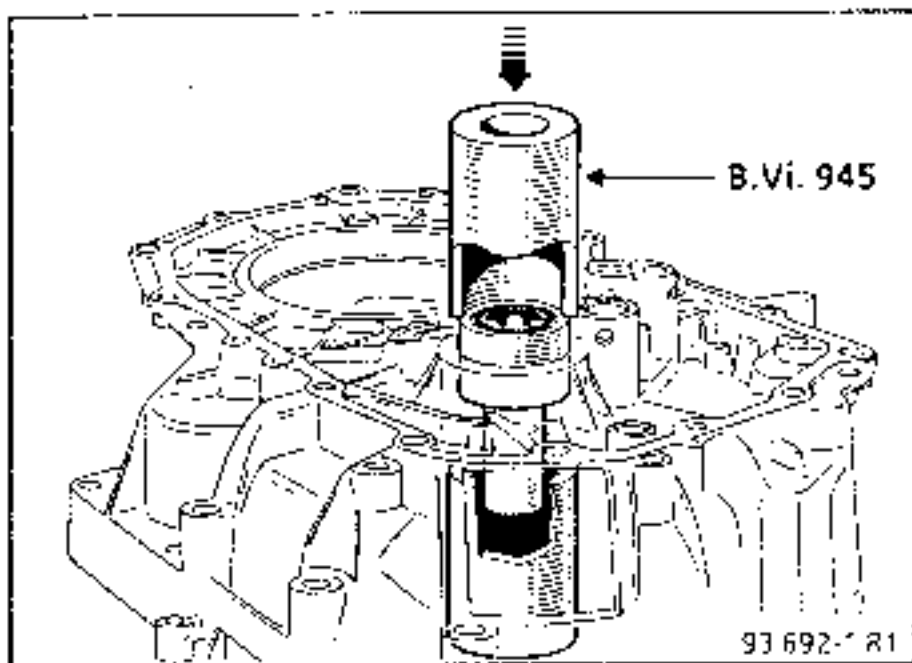

Check that the lubrication hole (A) is opposite the hole in the bellhousing (B).

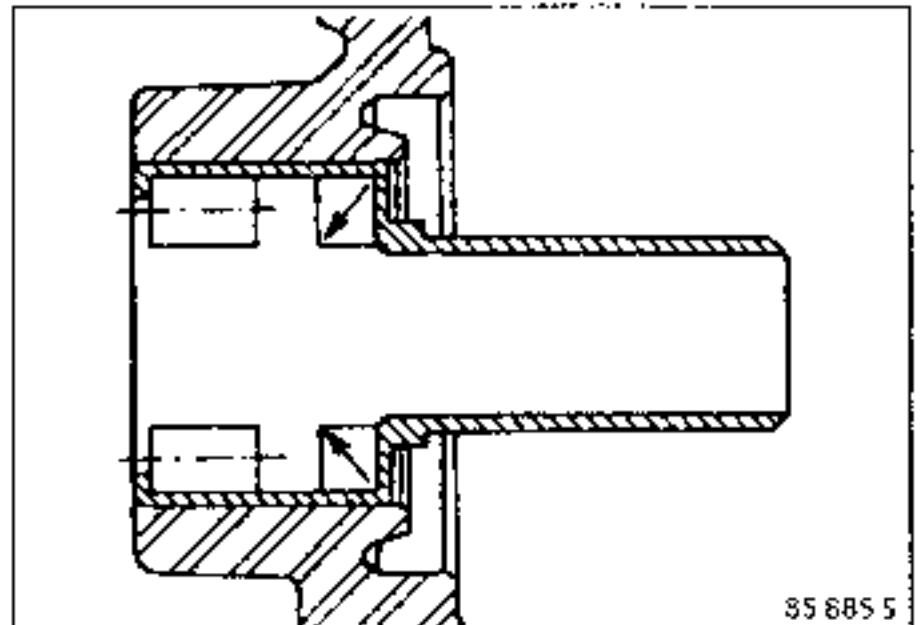

Lubricate the shaft before refitting.

Coat the bellhousing assembly faces with **Loctite 513**.

Replace the bellhousing and torque tighten the bolts to **2,5 daN.m**.

Coat the thrust pad guide tube with **MOLY-KOTE BR2**.

JB1

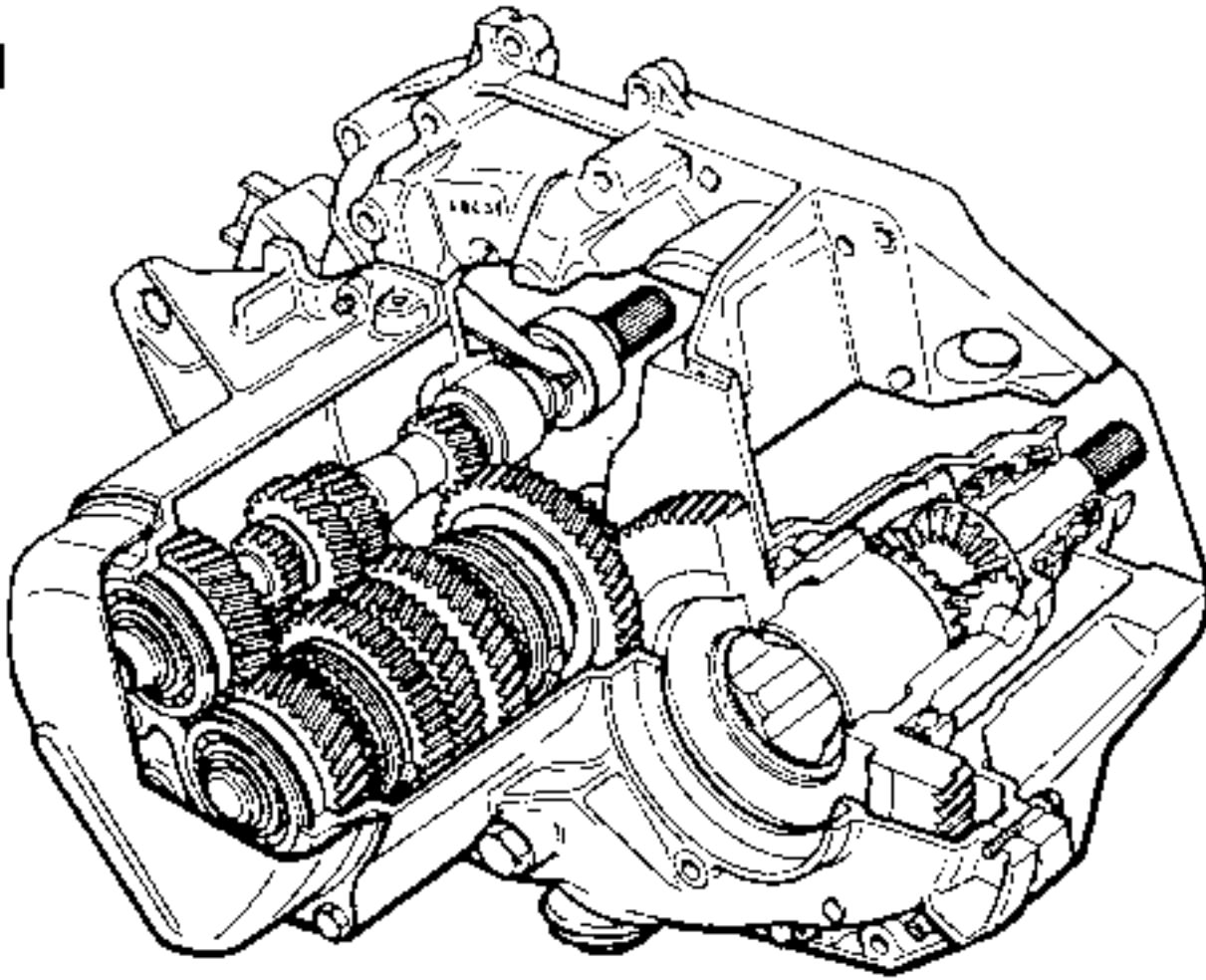

C06 vehicles are fitted with a JB type gear box.

The Repair Manual "B.V JB" covers the complete repair of this component

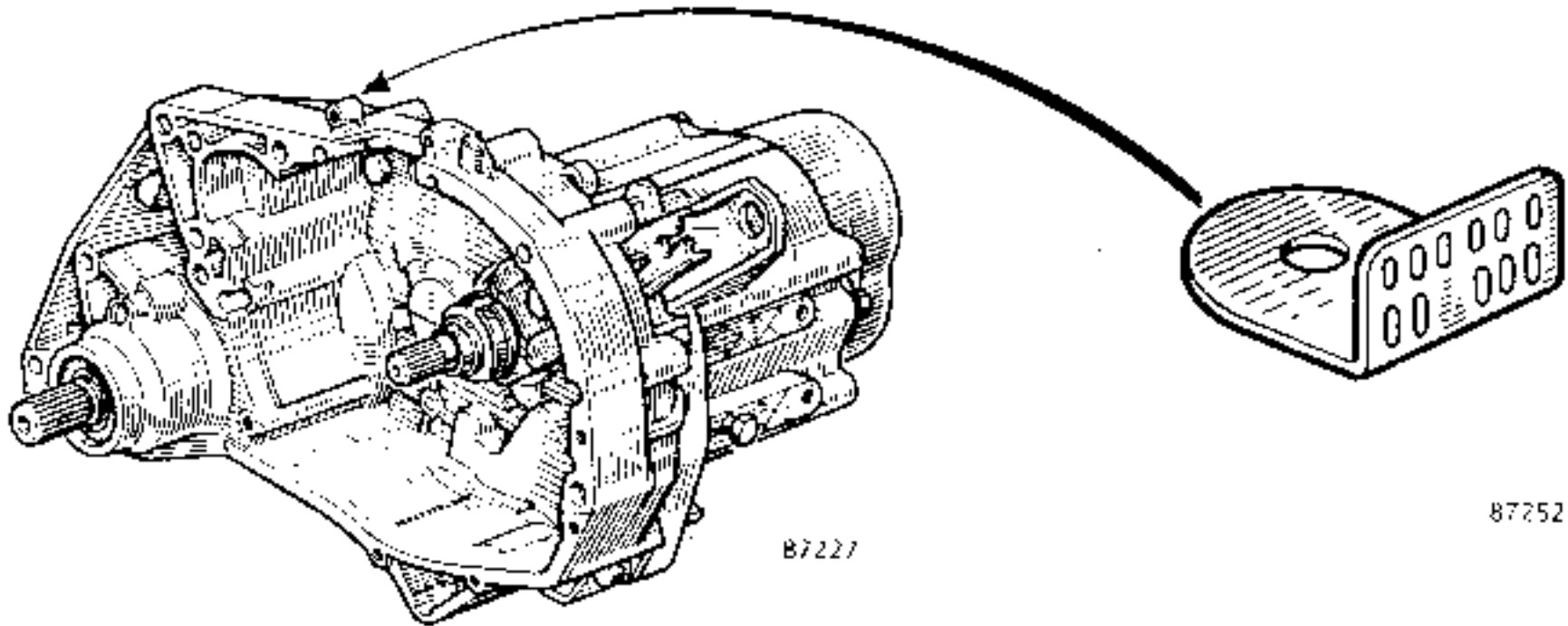

A plate on the clutch bellhousing shows .

- At A : The gear box type
- At B : the gear box suffix
- At C : the fabrication number
- At D : the factory of manufacture
- At E : a cut out section if the gear box has been fitted with a C type engine



90 775

### TWO COLOUR MARKING

2/3 of the surface is painted with a colour specific to that type of gear box.

The remaining 1/3 is painted with a colour which indicates the gear box suffix

Suffix	Vehicle	Step-down	Speed gear	1st	2nd	3rd	4th	5th	Reverse
<b>JB1</b>									
052	C063	$\frac{15}{56}$	$\frac{21}{20}$	$\frac{11}{41}$	$\frac{21}{43}$	$\frac{28}{37}$	$\frac{30}{29}$	$\frac{41}{31}$	$\frac{11}{39}$ 26

## Capacity - Lubricants

### CAPACITY

5 speed gear box JB1 : 3,40 l

### OIL GRADE

TRANSELF B80W

### FREQUENCY OF OIL CHANGES

Lubricated for life

### CHECKING THE LEVEL

1st service, then every 12500 miles (20 000 km)

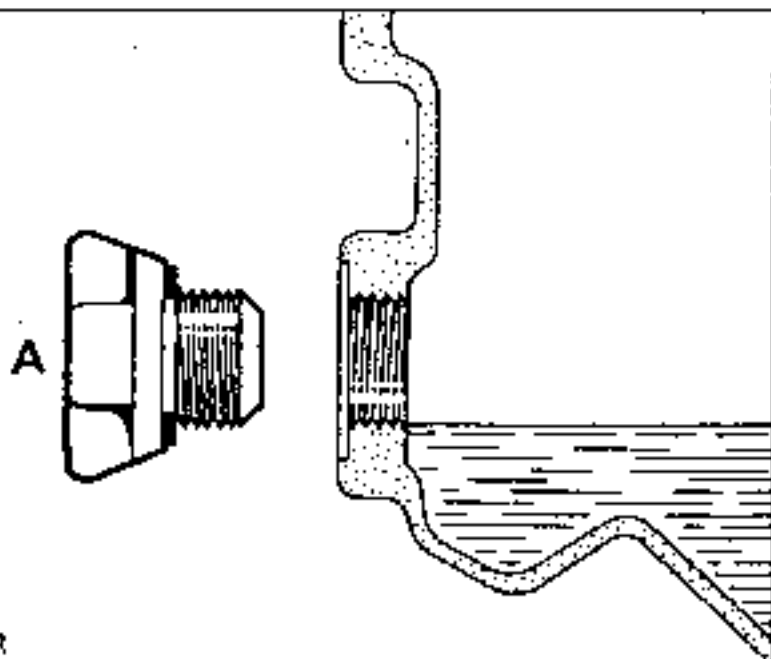

92 081 R

Fill up to the level of the hole.

Gear box JB1 (5 forward gears - 1 reverse gear) is fitted with BORG-WARNER synchronisers.

### GEAR LAYOUT

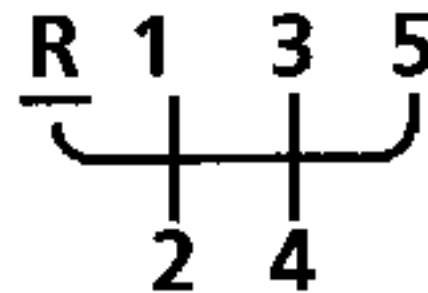

B.V. JB

To engage reverse gear, lift the ring (A) and move the lever.

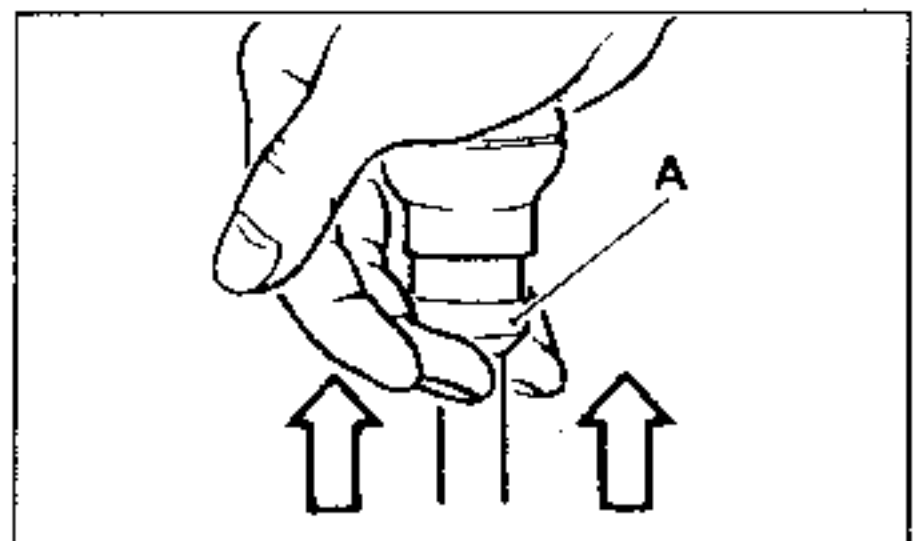

Type	Packaging	Part No.	Use for:
MOLYKOTE BR2	1 kg tin	77 01 421 145	Right hand sun wheel splines Fork pivot Thrust pad guide Fork pads 
Loctite 518	24 ml syringe	77 01 421 162	Housing assembly faces
CAF 4/60 THIXO	100 g tube	77 01 404 452	Threaded plugs and switches Bearing plugs Ends of drive shaft roll pins
LOCTITE FRENBLOC (sealing and bonding resin)	24 cc bottle	77 01 394 071	Primary and secondary shaft nuts 5th gear fixed gear and hub Differential lock drive stud

## Parts to be replaced systematically

When they are removed :

- paper seals,
- lip seals,
- differential housing mounting bolts,
- roll pins,
- reverse gear inverter bolt,
- O rings,
- locking rings,
- thrust pad guide tube,
- primary and secondary shaft nuts,
- speedometer gear.



Noise when a gear is engaged

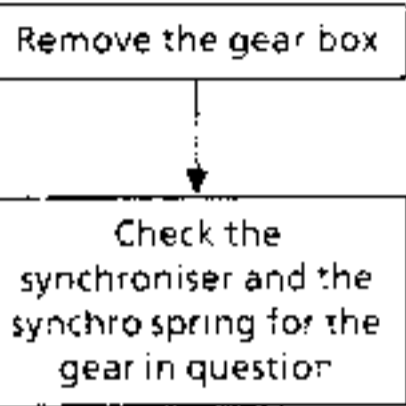

Noise when every gear is engaged (after checking the clutch)

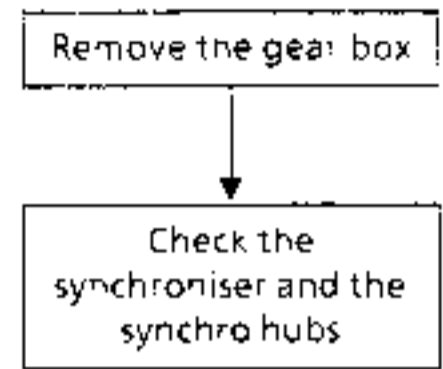

Gears cannot be engaged (after checking the clutch)

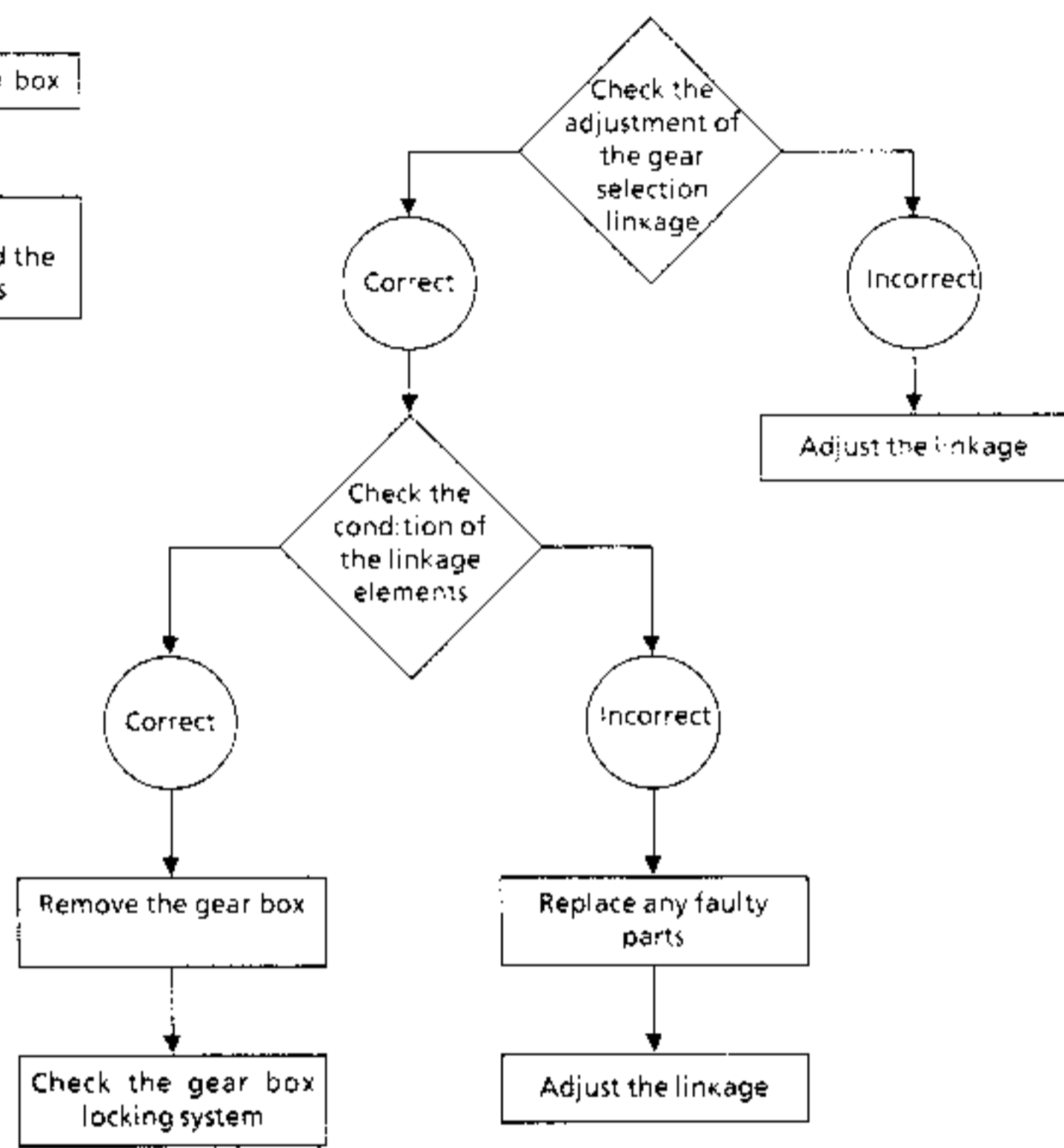

KEY

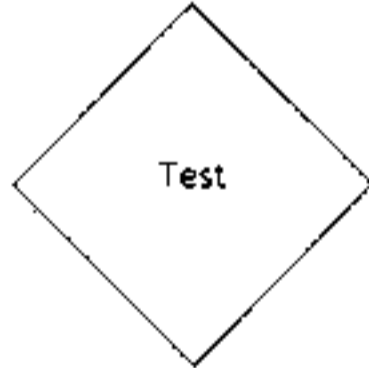
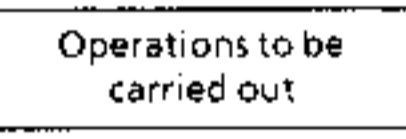

Abnormal noise when on the road

- Stop the vehicle
- Engine running
- Gear lever in neutral

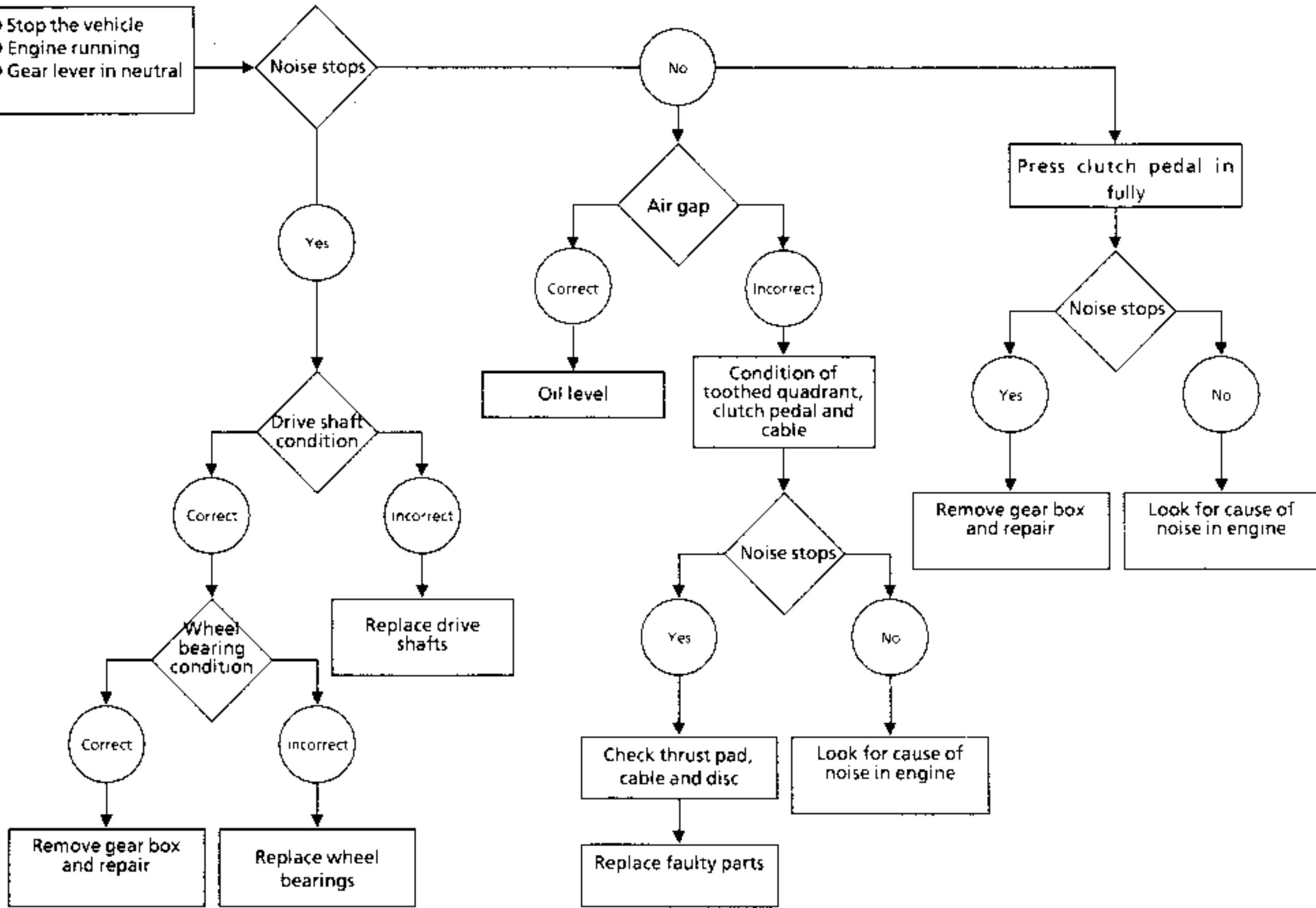

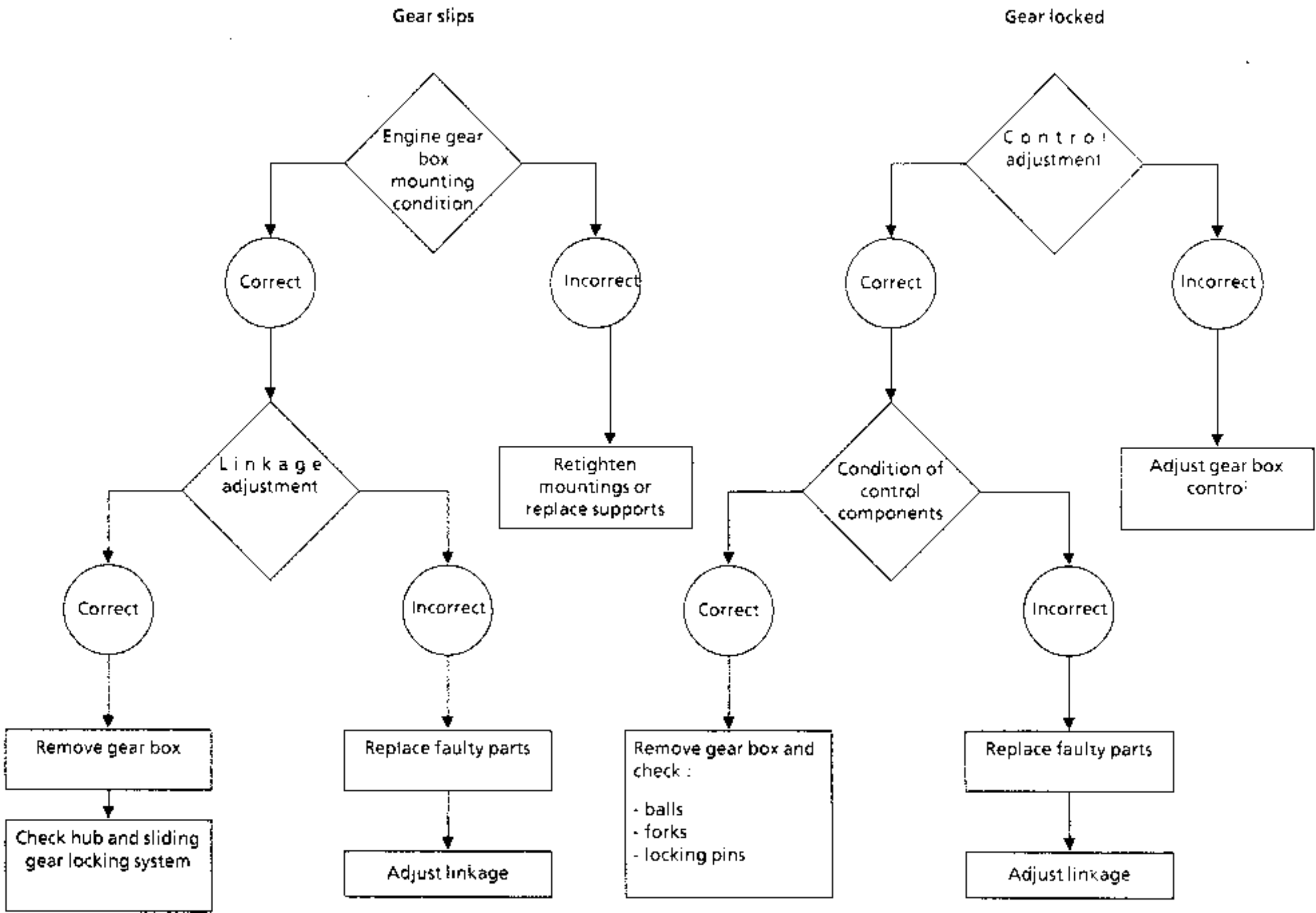

SPECIAL TOOLING REQUIRED	
B.Vi. 31-01	Set of pins
T.Av. 476	Ball joint extractor
SPECIAL MATERIALS REQUIRED	
CELETTE 918.910	Component support

TIGHTENING TORQUES (in daN.m)	
Engine - gear box mounting nuts and bolts	5
Clutch protector mounting bolt	2,5
Drain plug	1,8
Filler plug	0,15
Left hand drive shaft gaiter mounting bolt	2,5
Brake caliper mounting bolt	10
Shock absorber base mounting bolts	11
Track rod end nut	3,5
Stub axle carrier pin nut	5,5
Support mounting bolt	4 to 5
Wheel bolts	9

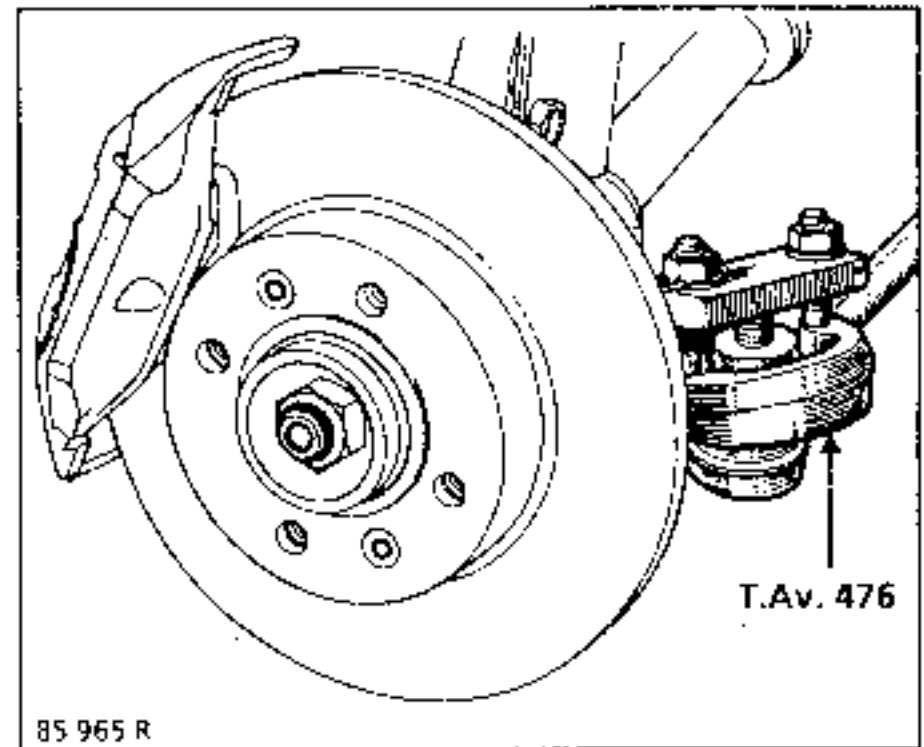

- the three drive shaft gaiter mounting bolts,

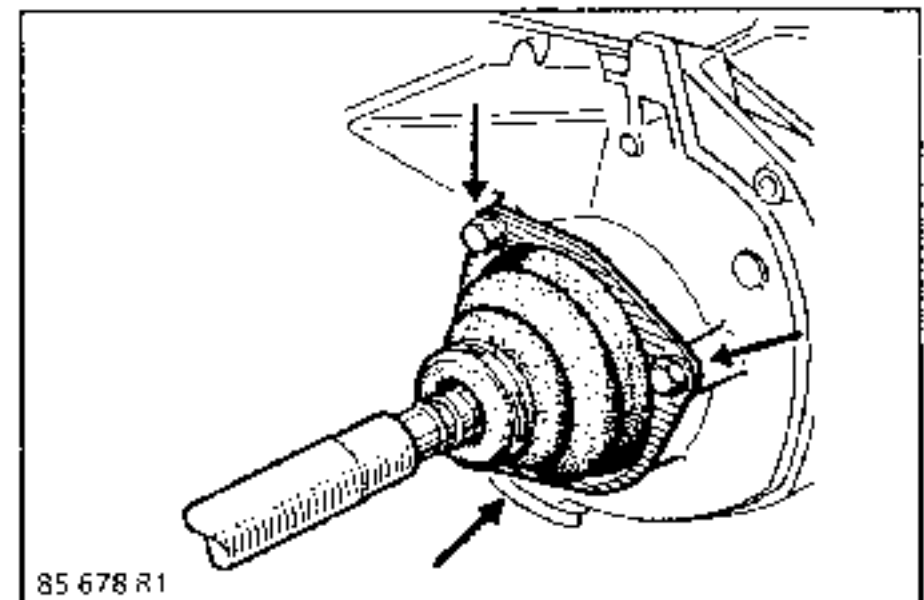

- the two mounting bolts for the brake caliper and attach the caliper to the suspension spring to avoid pulling the brake hose.

## REMOVAL

Place the vehicle on a lift or on axle stands.

Disconnect the battery.

Remove the engine undertray.

Drain the gear box.

Remove the front wheels

*From the left hand side of the vehicle, remove:*

- the track rod end using tool T.Av. 476,

**Remove:**

- the two shock absorber base mounting bolts (1)
- the nut and the pin bolt (2),

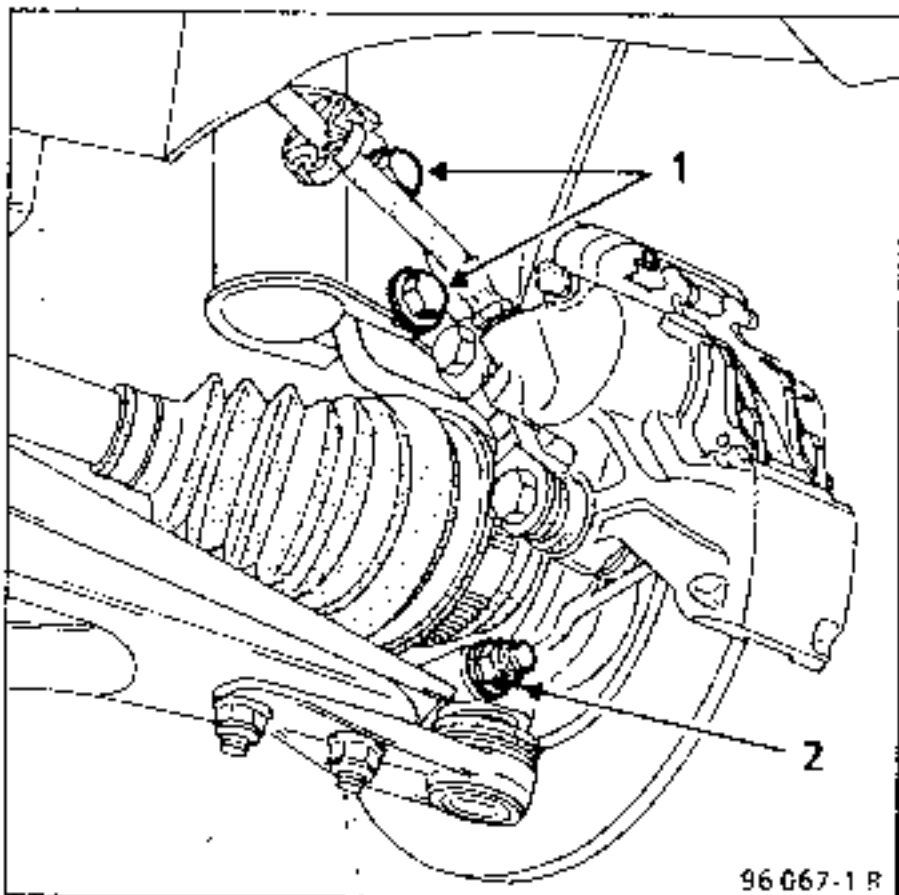

- the mudguard,
- the stub axle carrier and drive shaft assembly from the lower ball joint.

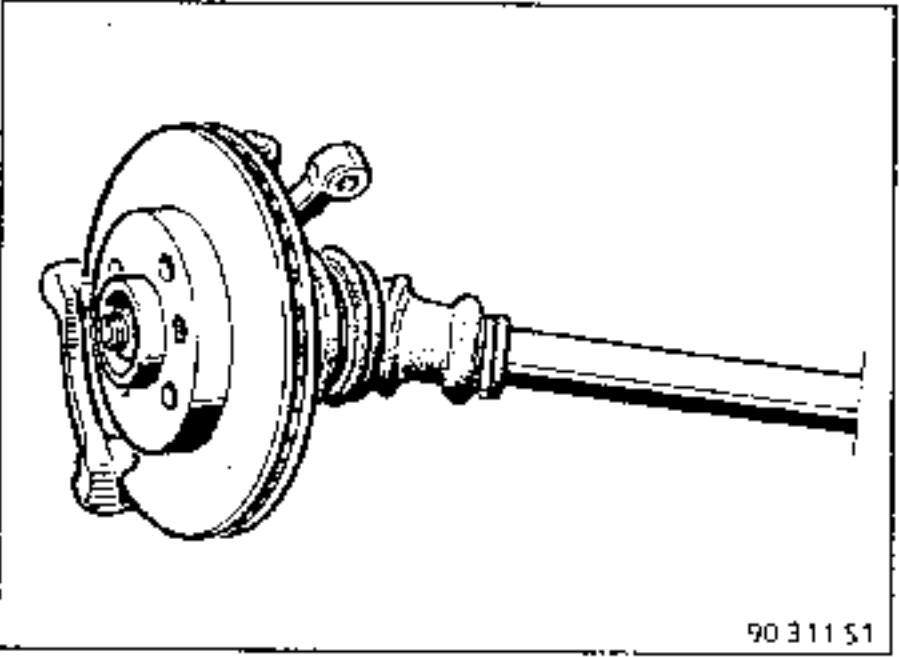

Check that the drive shaft rollers do not come out by hand. If they do, check that the needles have not fallen into the unit when refitting.

From the right hand side of the vehicle, remove the drive shaft roll pins using tool B. Vi. 31-01.

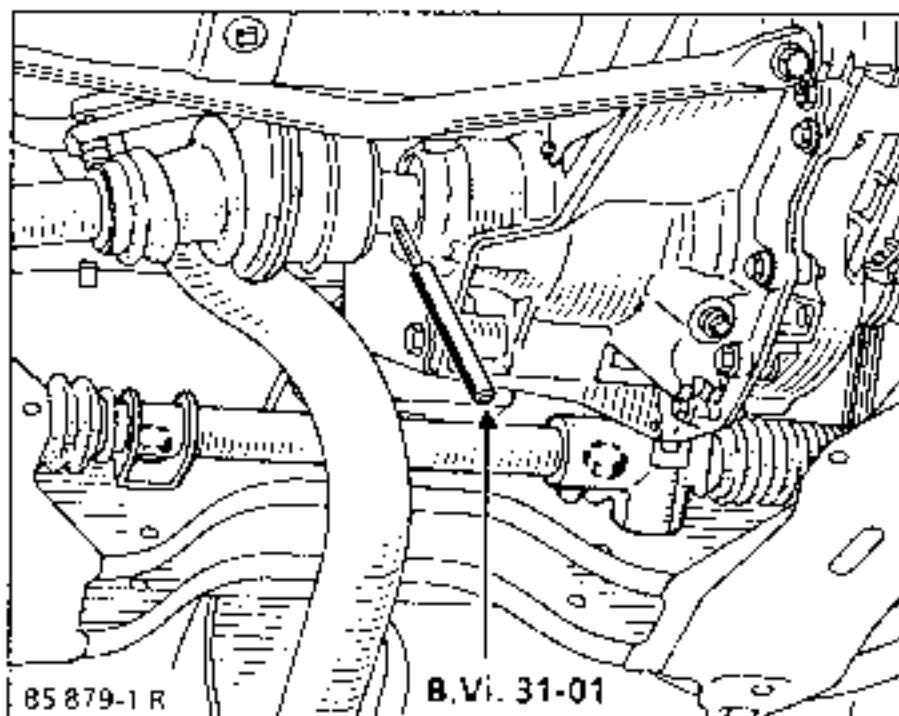

Undo the lower shock absorber base bolt (3) and remove the upper ball

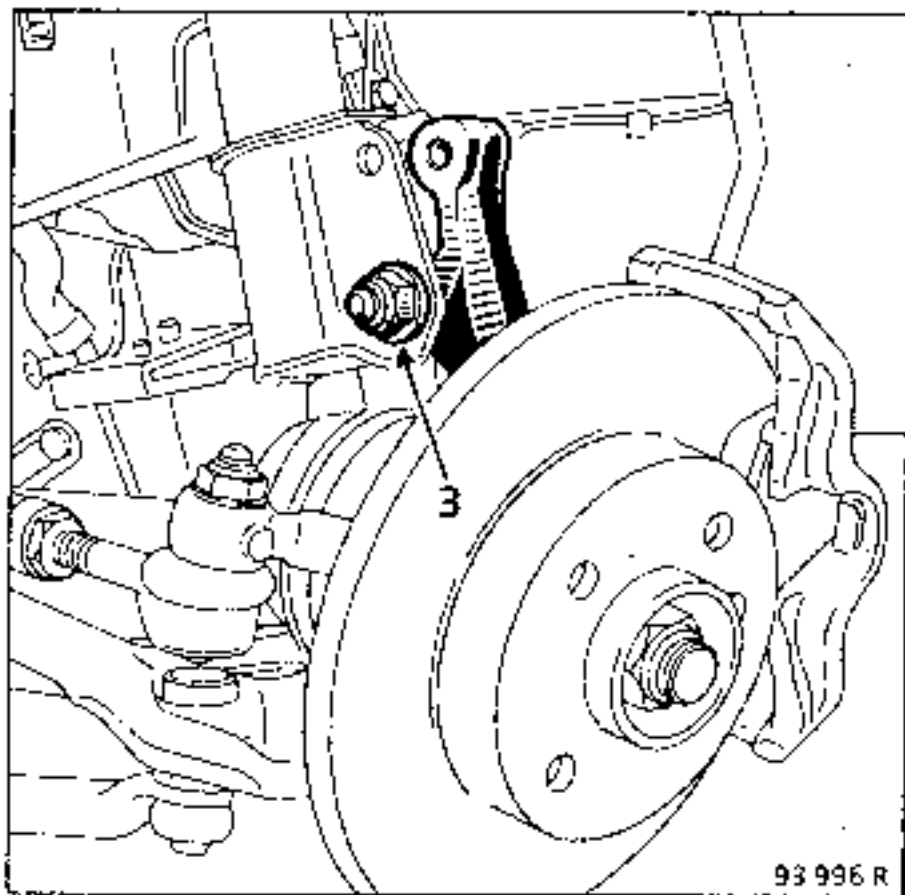

Tilt the stub axle carrier and uncouple the drive shaft

- Remove:
- the air filter unit,

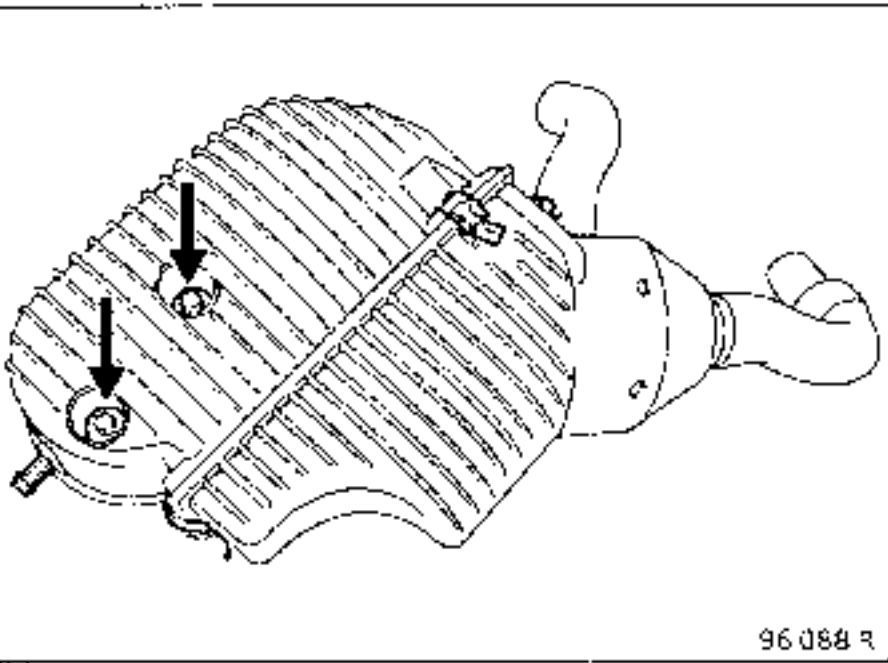

- the ignition coil.

- Disconnect:
- the clutch cable,

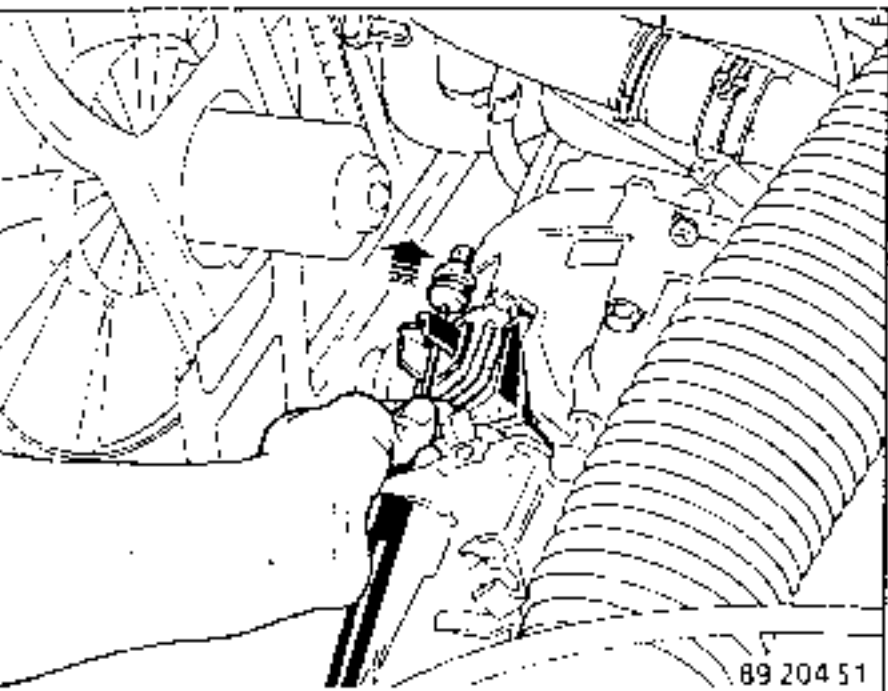

- the speedometer connector,
- the oxygen sensor connector,
- the reversing lights switch connector.

- Remove:
- the TDC sensor,
  - the earth strap.

Remove pin (E) and disconnect the speedometer cable.

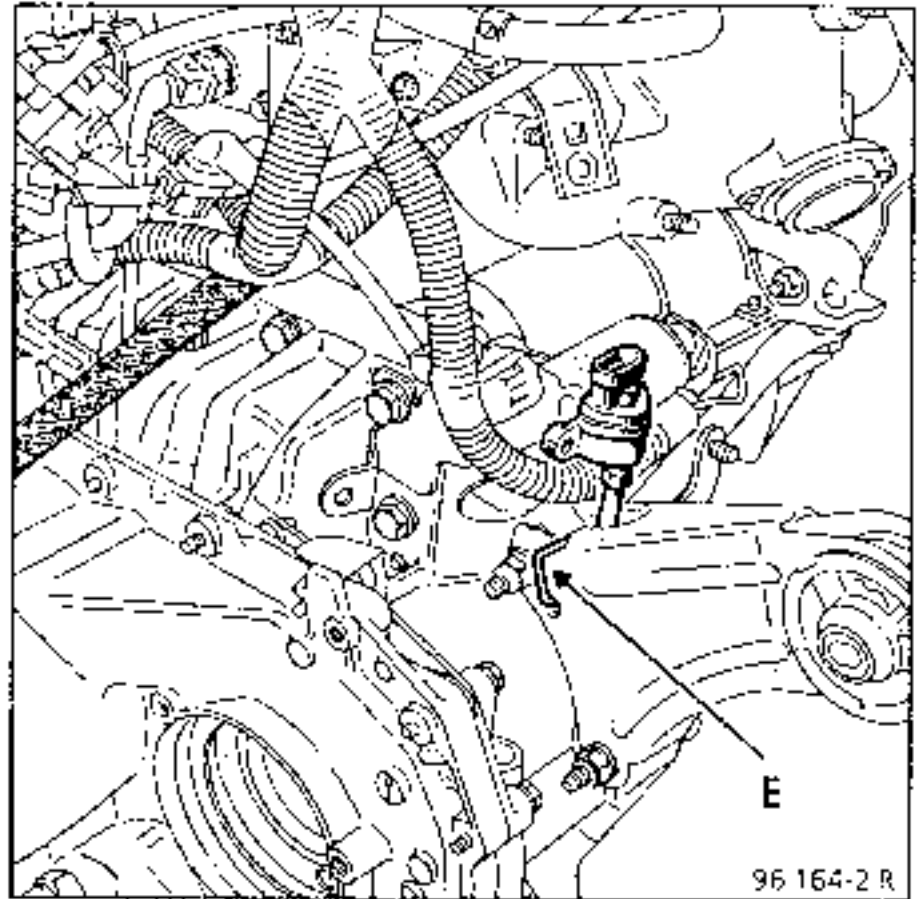

Uncouple the gear box control from the gear box output lever having removed the protective gaiter.

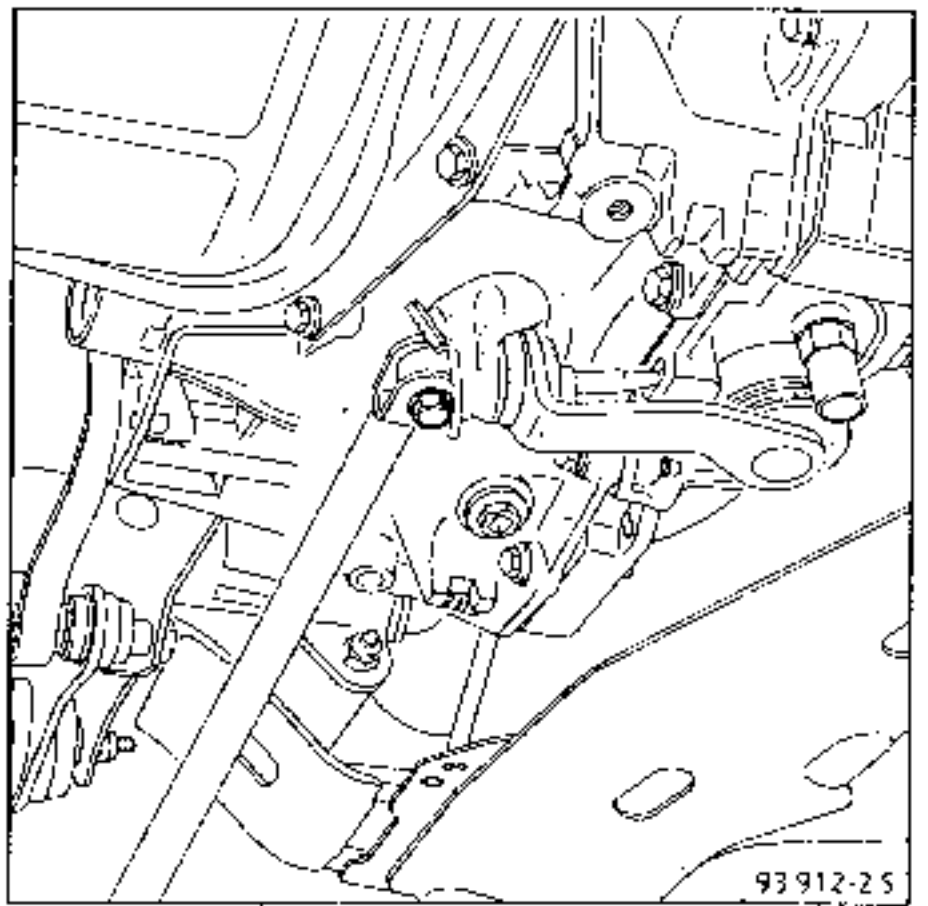

Remove:

- the catalytic converter (3),
- the heat shield (4).

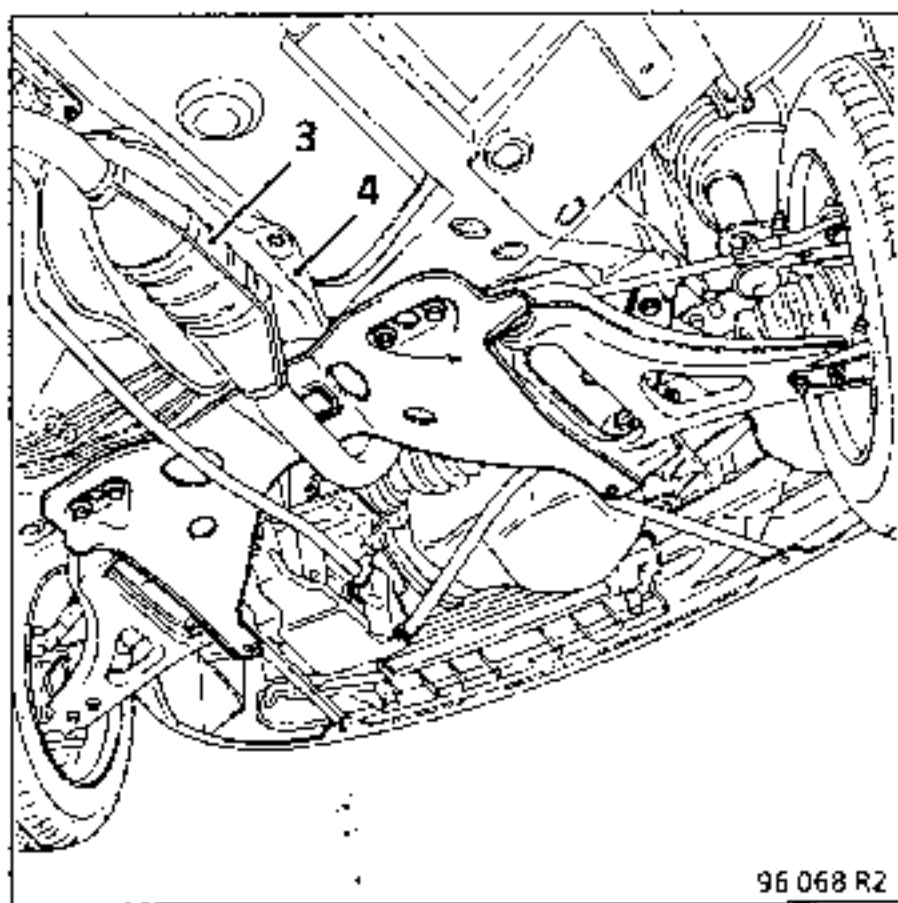

- the engine - gear box tie-rod,
- the two stiffeners,

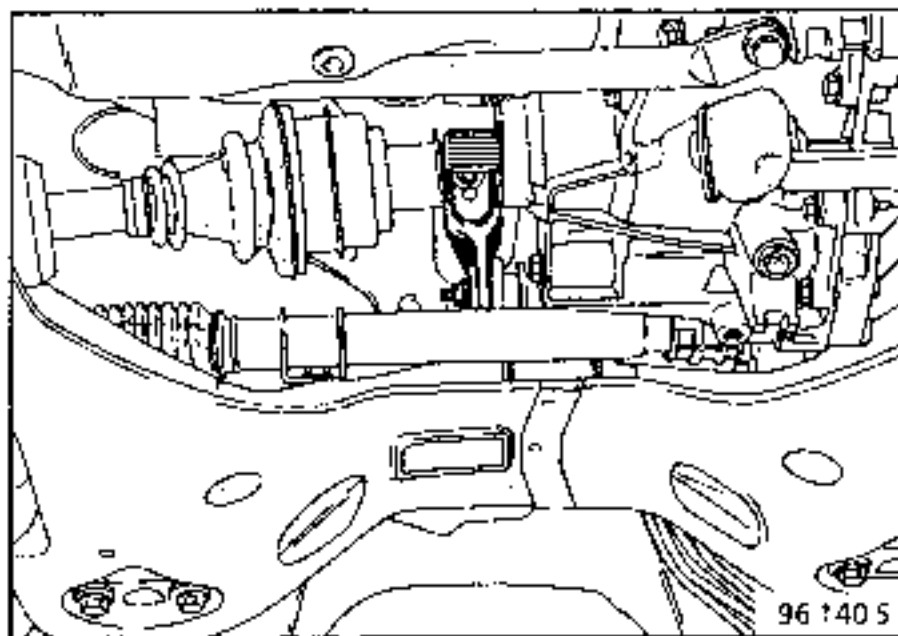

- the clutch protective plate,
- the engine - gear box mounting nut.

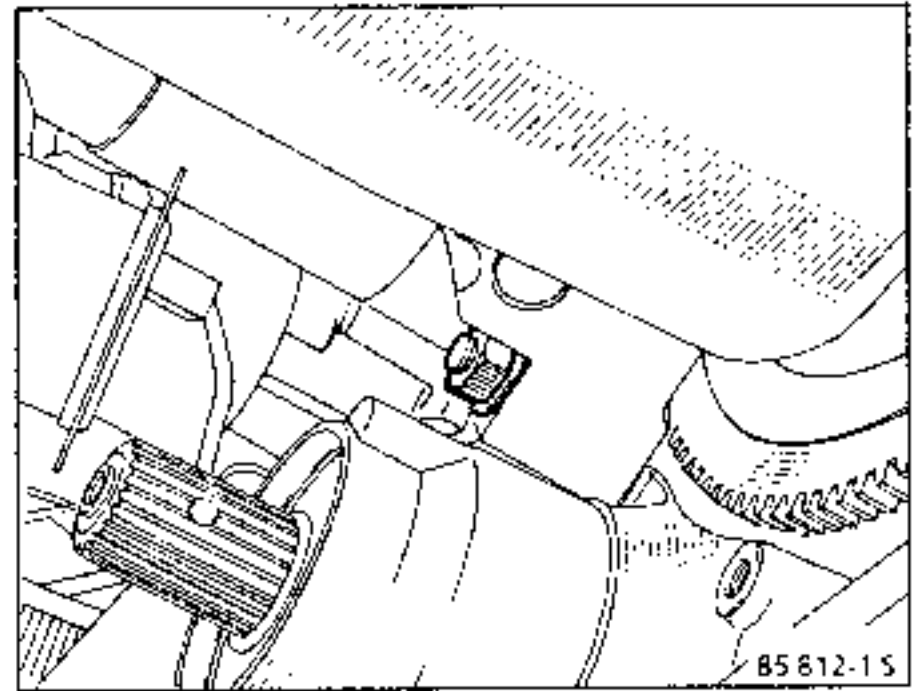

Using support bar **CELETTE 918-910** or an equivalent, support the weight of the engine. Ensure the bar is stable.

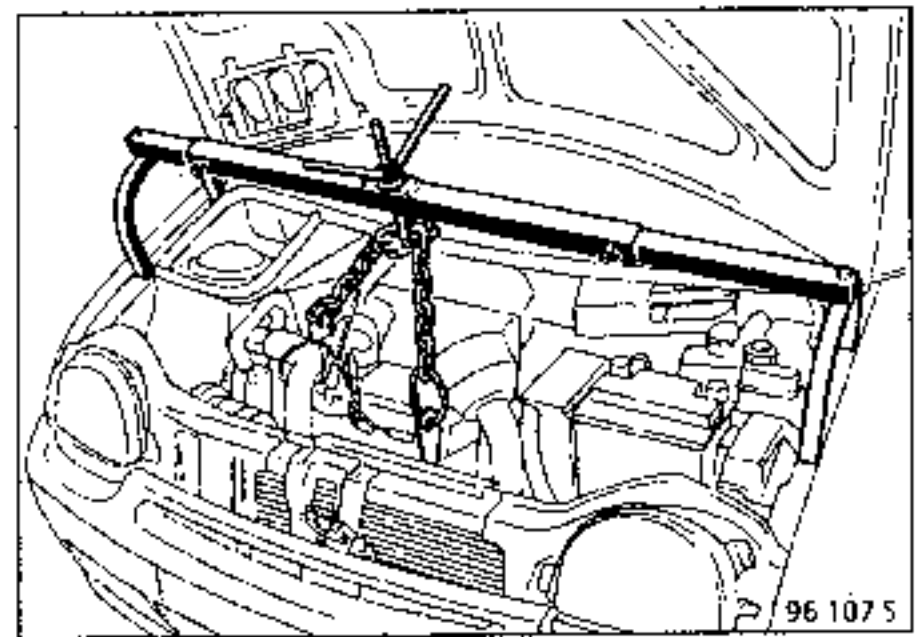

Remove the central support mountings and push it backwards.

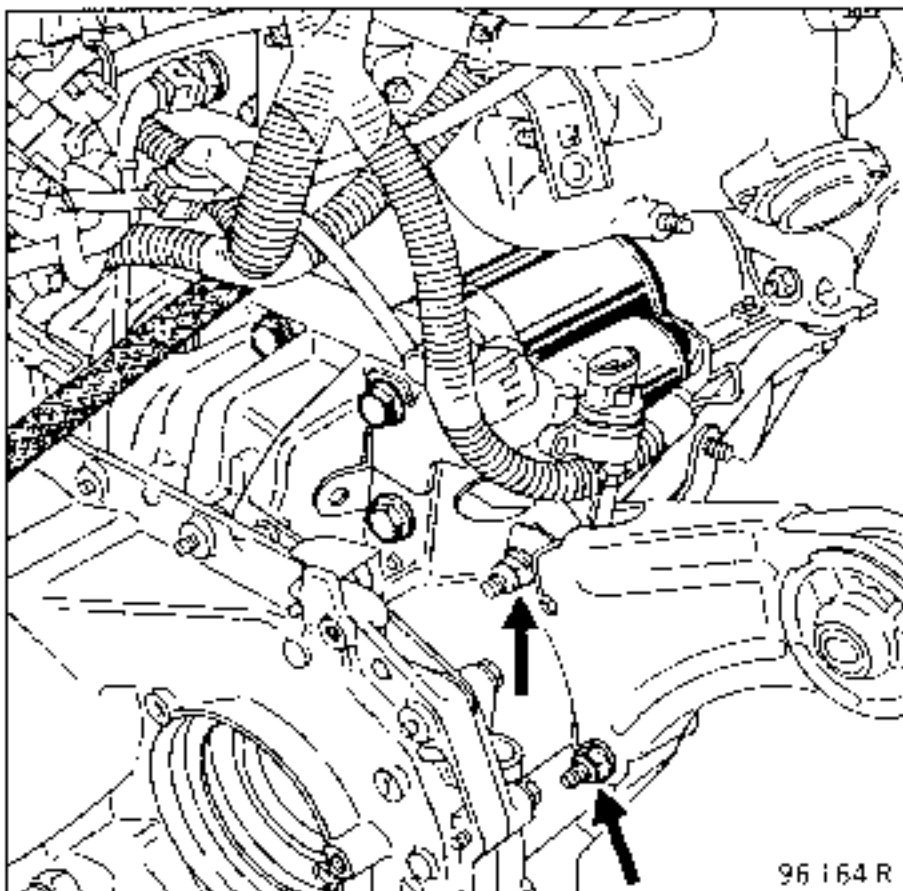

Remove studs (A) and (B) with a nut and locking nut, using an extension wrench and a ball joint socket.

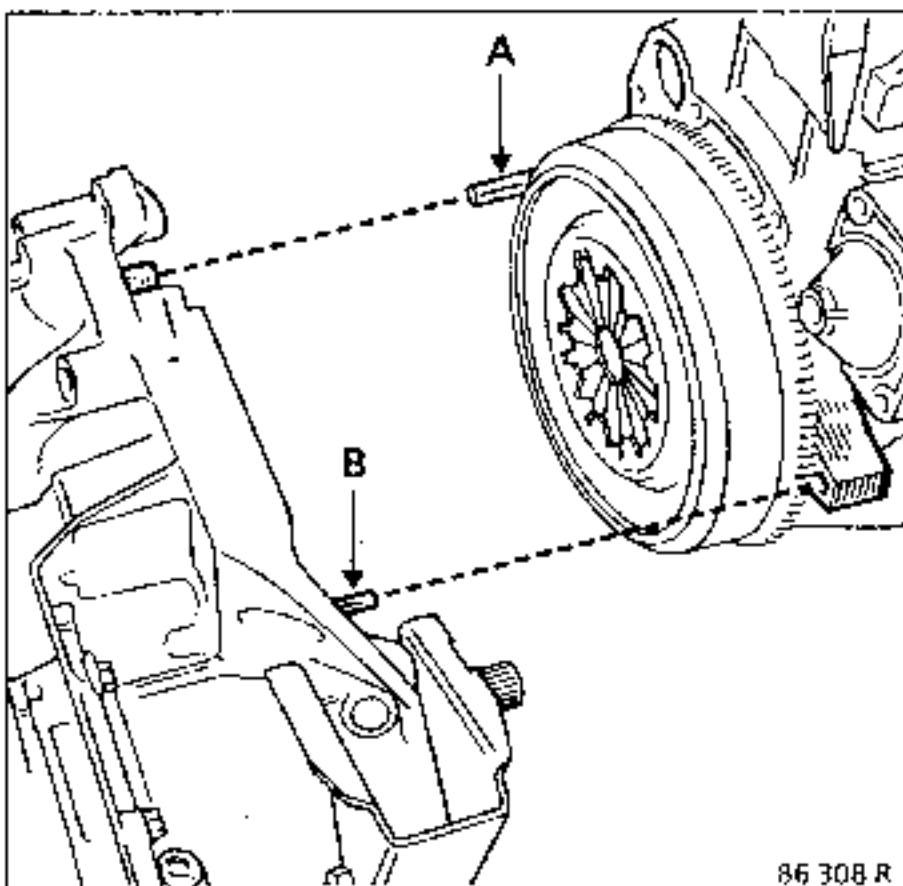

Remove the bolts around the gear box and starter.

Position a hydraulic jack under the gear box.

Remove the complete front left hand support.

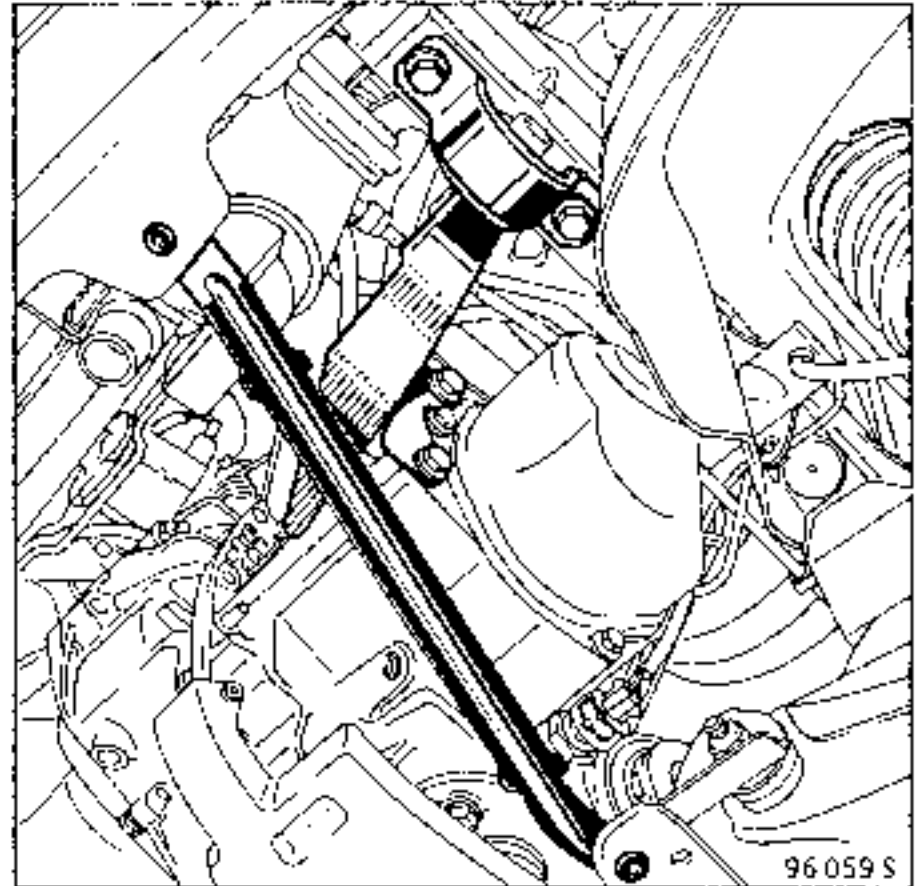

Separate the assembly from the passenger compartment and lower it so that the gear box may be uncoupled from the engine, then tilt it to remove it from the vehicle.



**REFITTING (Special notes)**

Ensure the engine - gear box centring rings are correctly positioned :

at C: gear box assembled with a C engine: long centring pins.

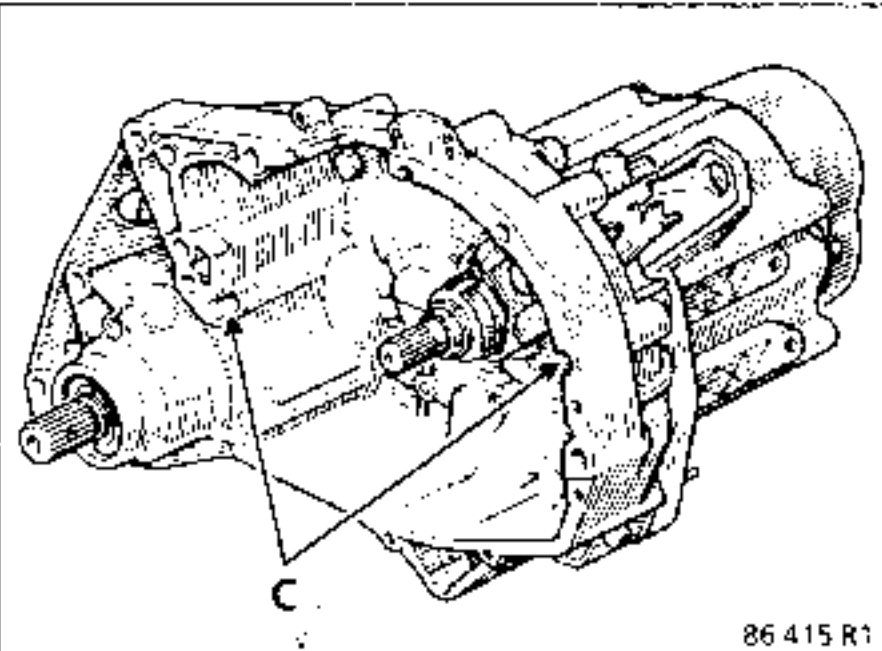

Check the position of the thrust pad, lug (E) in the fork.

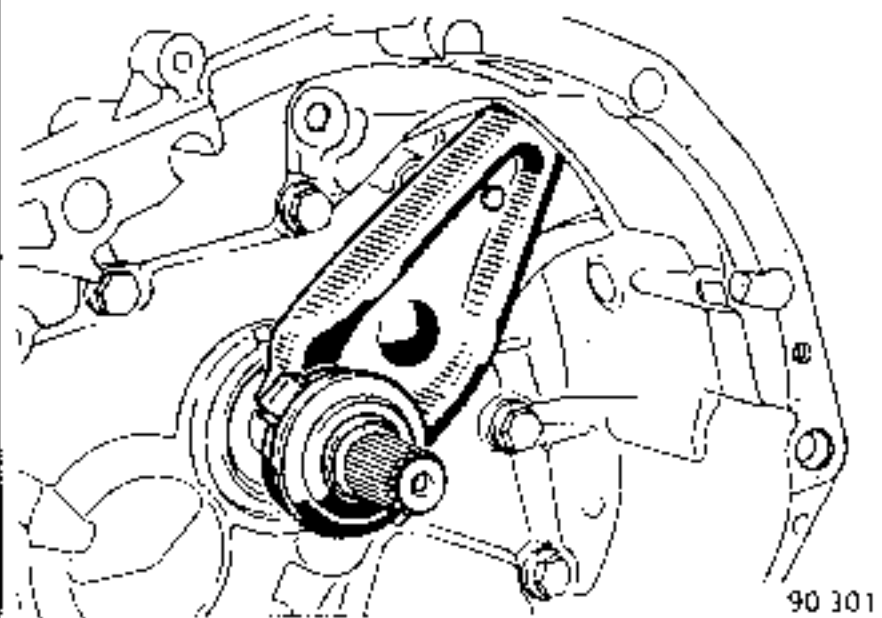
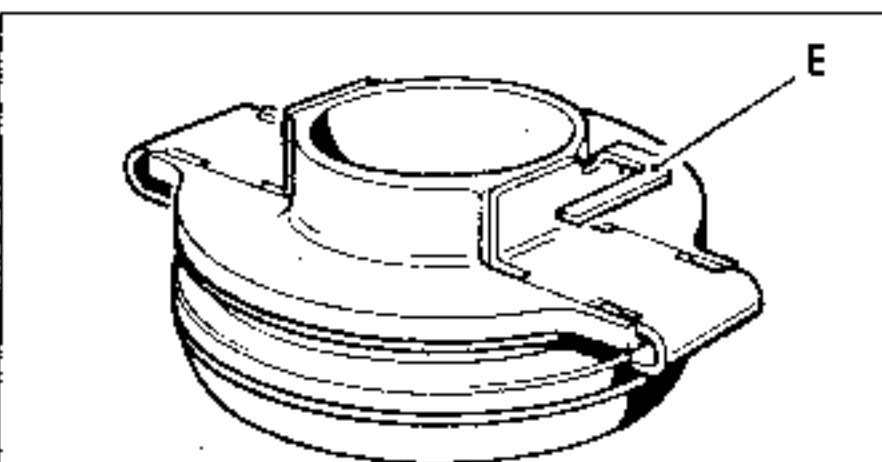

Assemble the gear box and engine.

Ensure the centring rings are correctly positioned.

Refit studs (A) and (B) in the same position from which they were removed; they are useful for aligning the gear box, as are the bolts round the edge of the component.

**ATTENTION :** ensure bolt (V) and the starter centring pin (D) are correctly positioned .

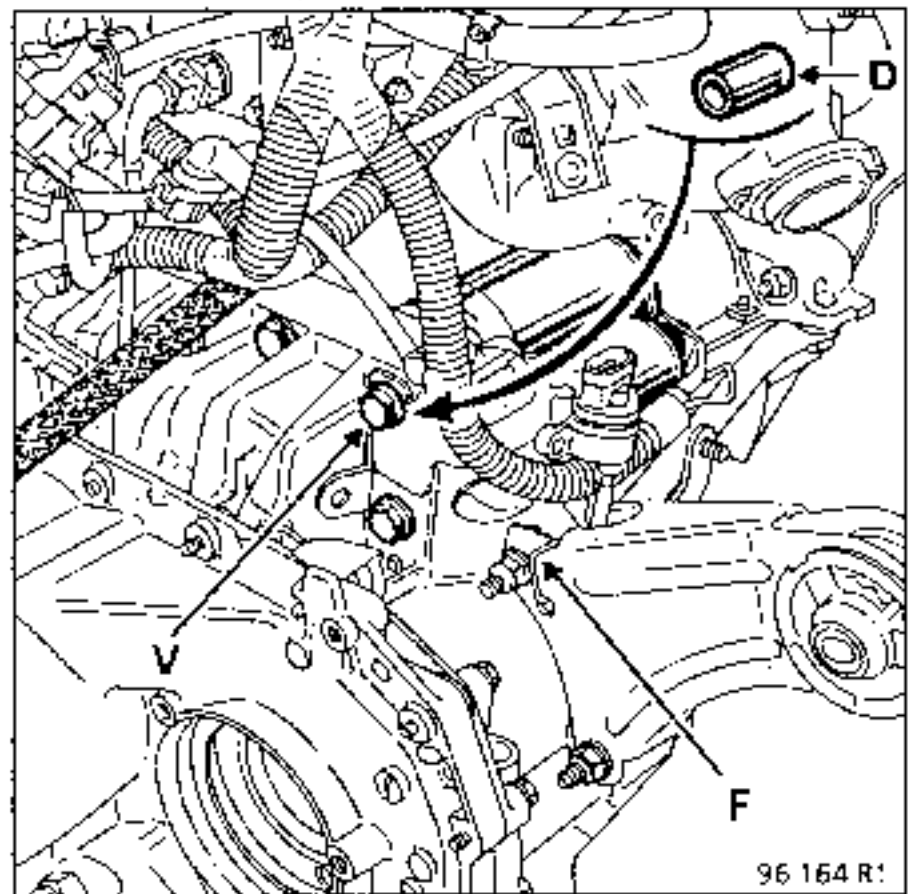

Reconnect the speedo cable ensuring pin (F) is correctly positioned.



**IMPORTANT :**

Check the position of the engine - gear box assembly and adjust if necessary (see chapter 10).

Position the drive shaft in relation to the sunwheel, pivot the stub axle carrier and fit the drive shaft on the sunwheel using pin **B. Vi. 31-01** to align the holes.

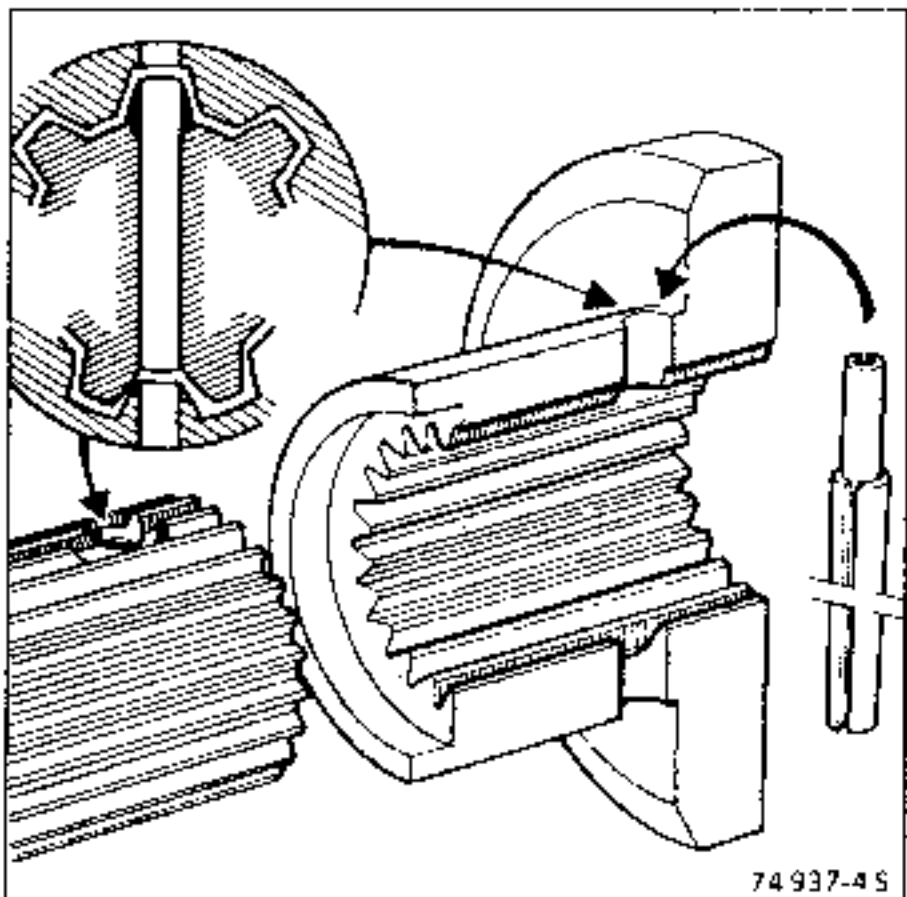

A chamfer on the sunwheel input side aids fitting the new roll pins.

Seal the ends (**CAF 4/60 THIXO**).

Fit the brake caliper mounting bolts using **Loctite FRENBLOC** and torque tighten.

Press the brake pedal several times to bring the pistons into contact with the brake pads.



Tighten all nuts and bolts to the recommended torque.

Fill the gear box with oil.

After refitting the assembly on the vehicle, check the fork travel. It should be :

**X = 17 to 18 mm**

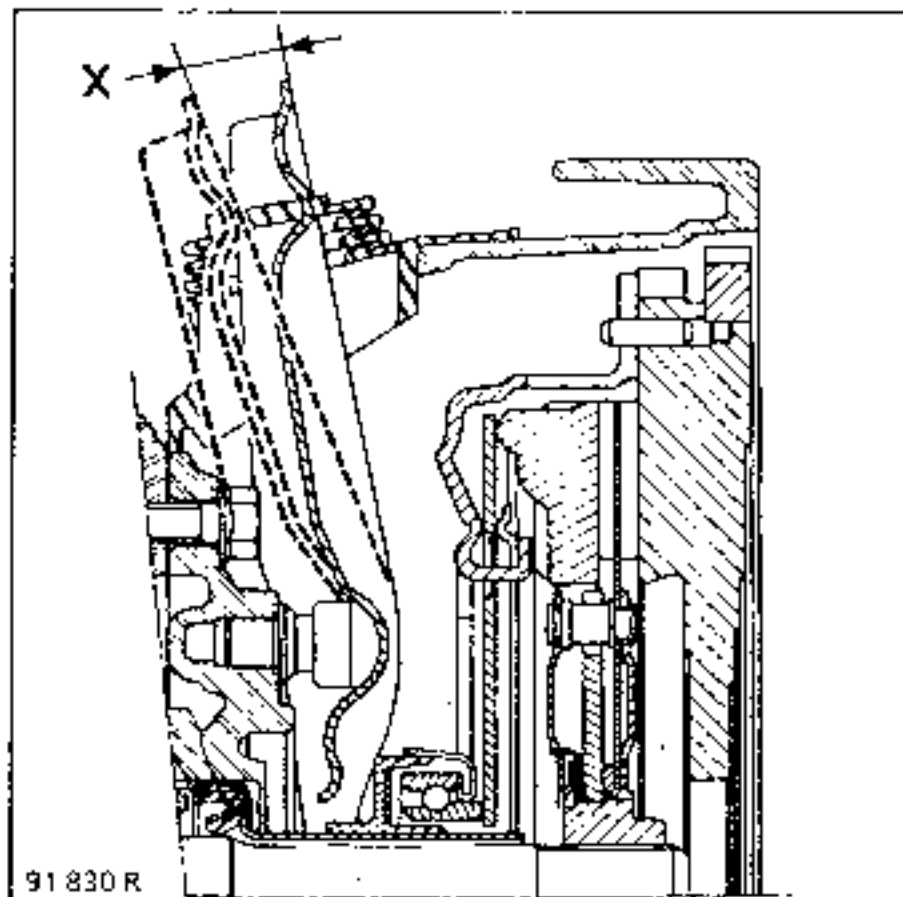

Pull the cable at the clutch fork on the gear box.

There should be at least **2 cm** of cable slack.

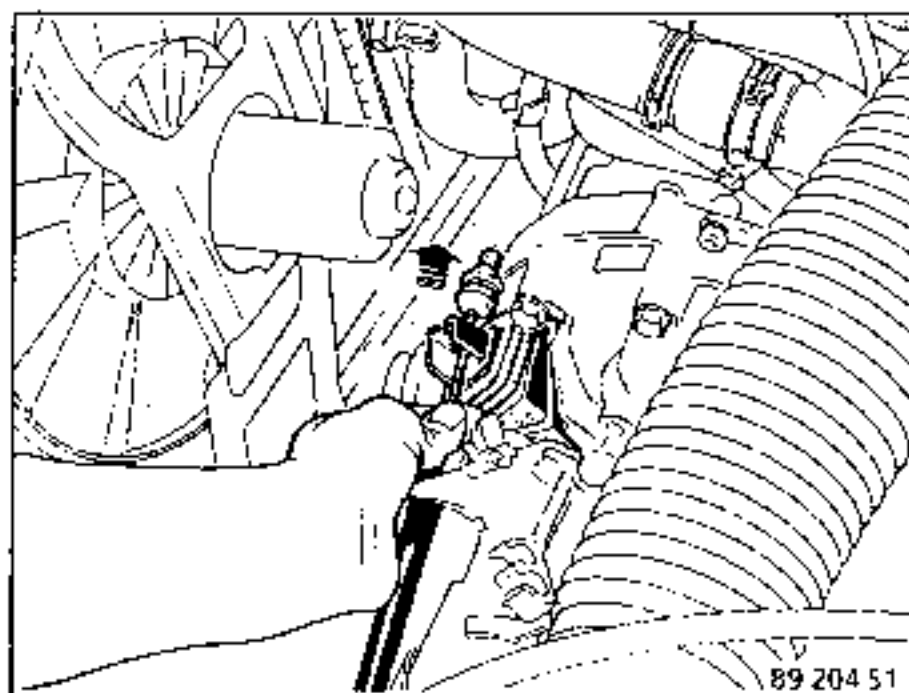

These tests allow the operation of the automatic wear compensation system to be checked.

SPECIAL TOOLING REQUIRED	
B.Vi. 22-01	Extractor body
B.Vi. 28-01	Bearing extractor with claws
B.Vi. 31-01	Set of pins for extracting and fitting $\varnothing$ 5 mm roll pins
B.Vi. 1000	5th gear fixed gear extractor
B.Vi. 1170	5th gear hub extractor
B.Vi. 1007	Claws for B. Vi. 28-01
B.Vi. 1175	5th gear fixed gear mounting bolt

TIGHTENING TORQUES (in daN.m)



Primary shaft nut	13,5
Secondary shaft bolt	8

REMOVAL

Remove the front left hand wheel

Remove:

- the engine undertray and drain the gear box,
- the left hand mud guard.

Place a draining tray under the rear housing and remove it.

The rear housing should be removed horizontally since it contains a lubrication tube (A) which enters the primary shaft.

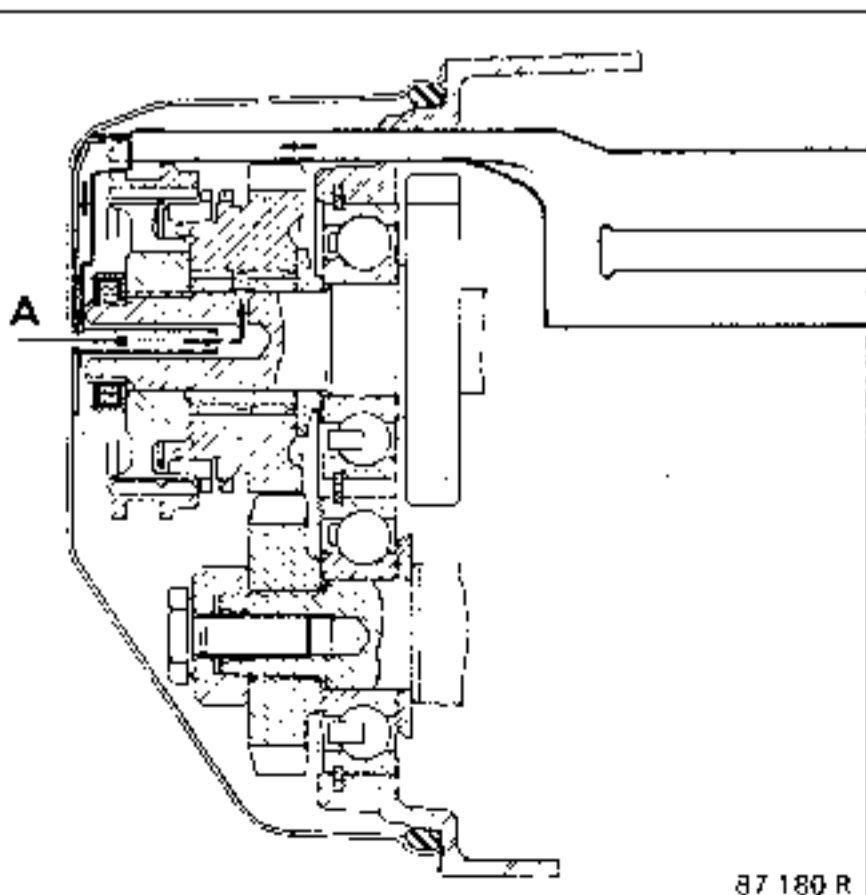

87 180 R

Fit a wooden block between the 5th gear fork and the drive gear for support; then remove the fork roll pin using tool B.Vi. 31-01

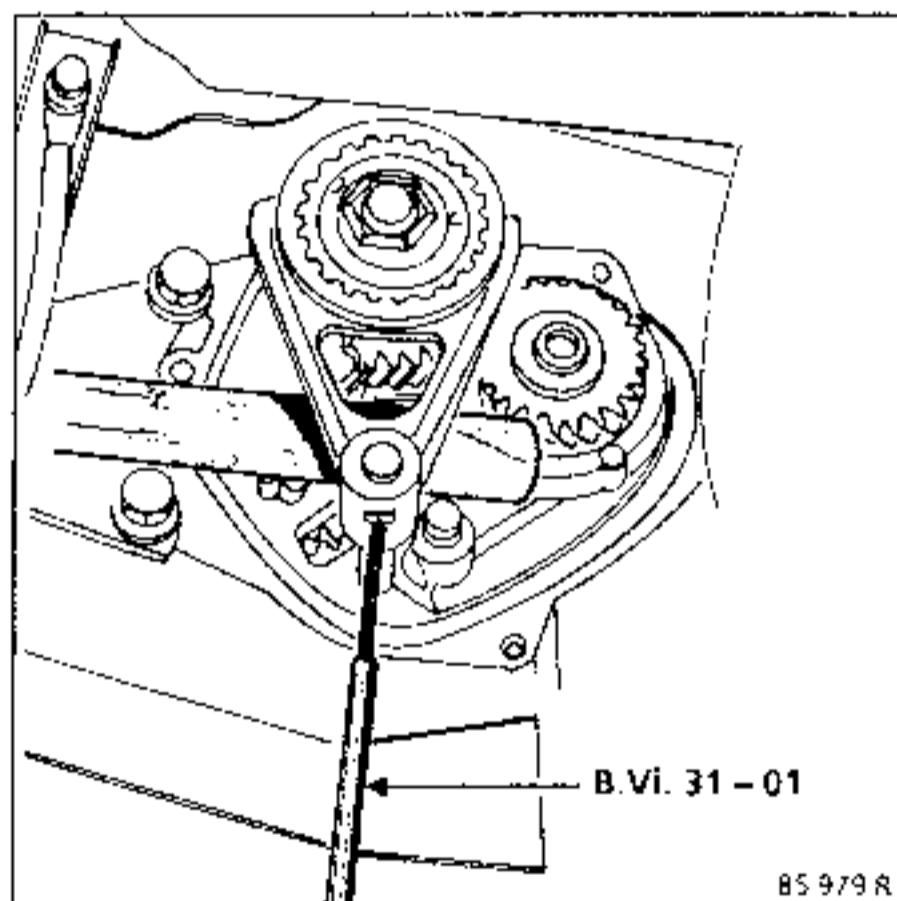

85 979 R

**NOTE:**

Do not pull the 5th gear fork shaft outwards, as the locking mechanism may move and prevent the gear being refitted; for safety, engage a gear (3rd or 4th) when removing and refitting the roll pin.

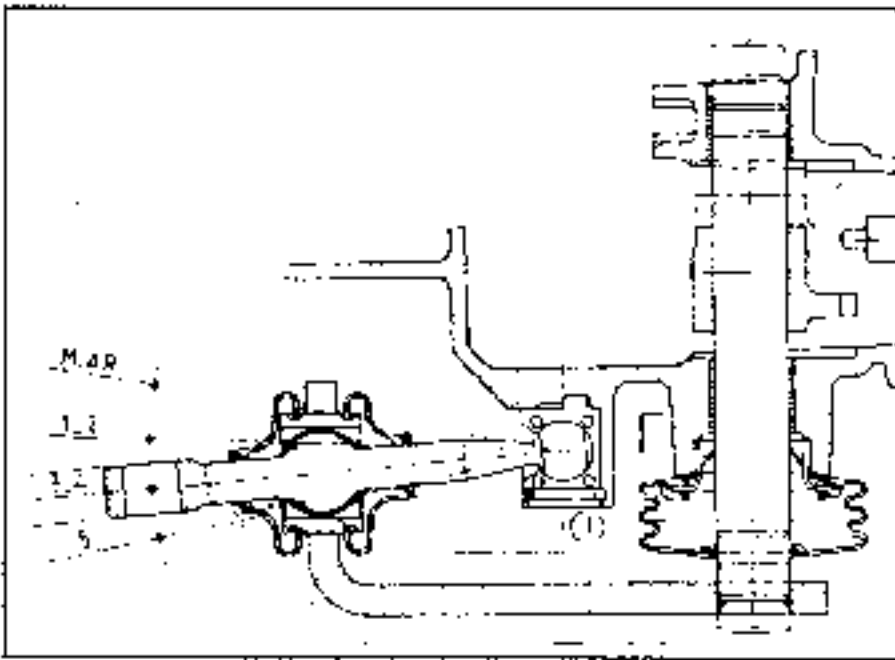

Lock 5th gear by sliding the fork on its shaft and selecting 1st with the gear lever.

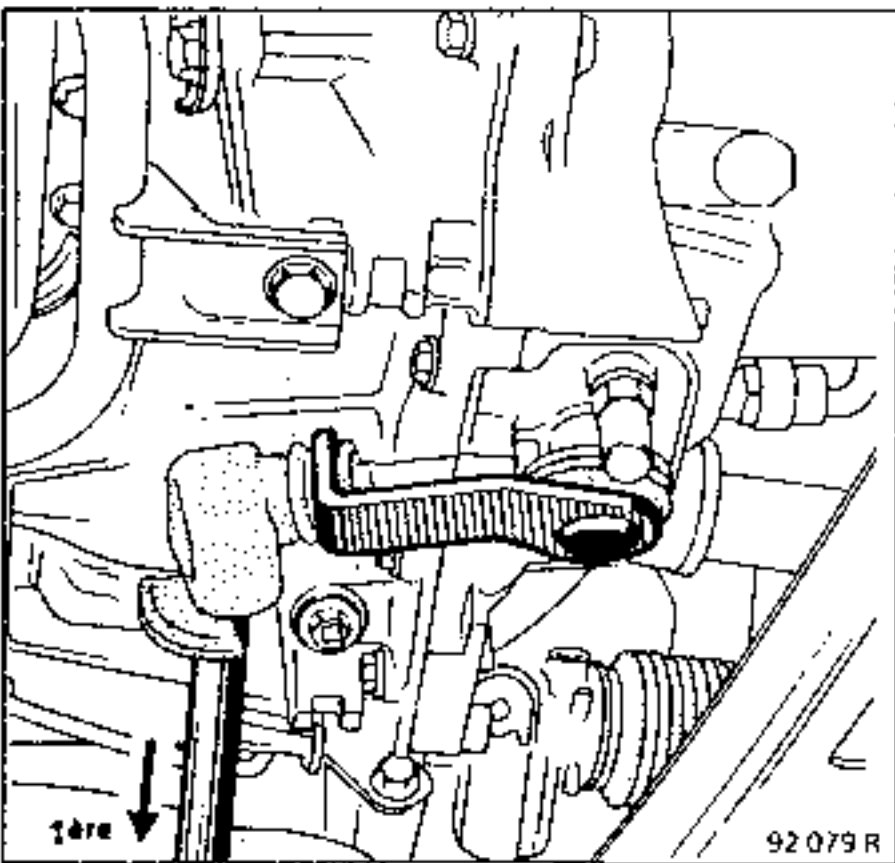

Loosen and remove the primary shaft nut and the secondary shaft bolt.

Return the gear box to neutral.

*On the primary shaft :*

Remove the 5th gear fork and the sliding gear.

Extract the synchroniser hub using tool B.Vi. 1170.

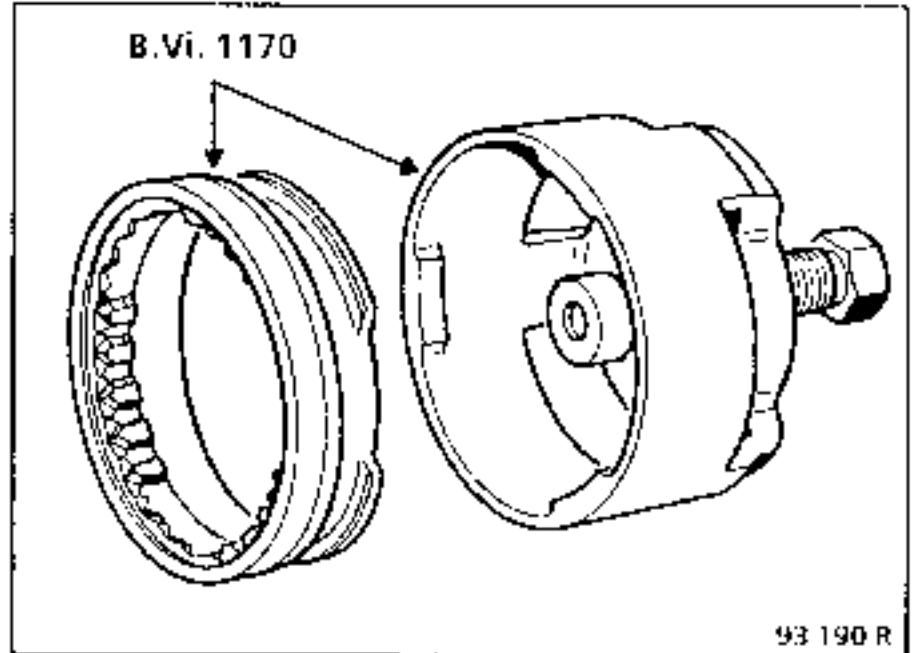

Fit the sliding gear of tool B.Vi. 1170 as for selecting 5th gear and turn it to align the splines of the sliding gear and the hub.

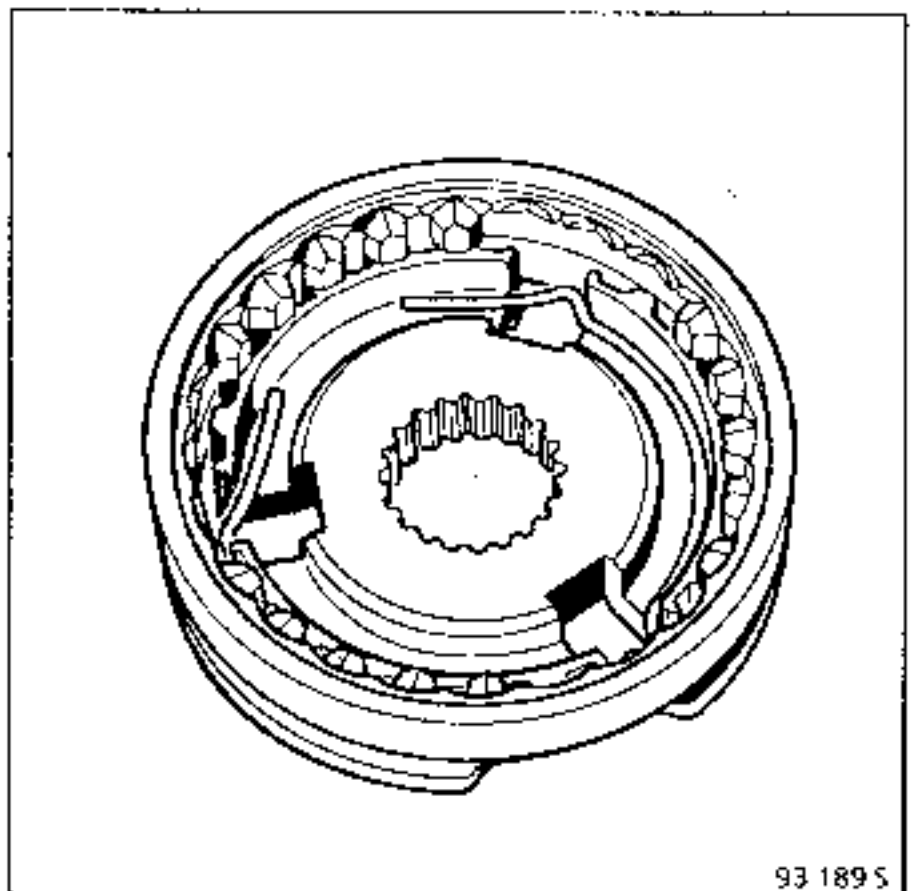

Fit the bell section of the tool on the sliding gear, turn it to the stop then extract the hub.

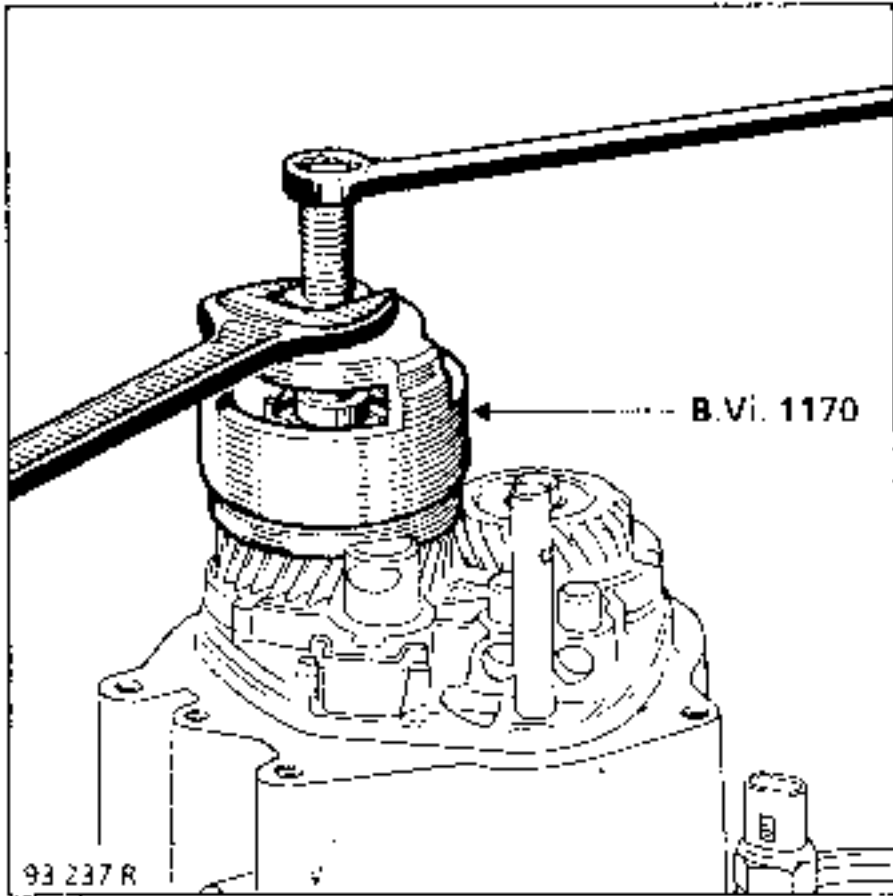

Remove the 5th gear assembly.

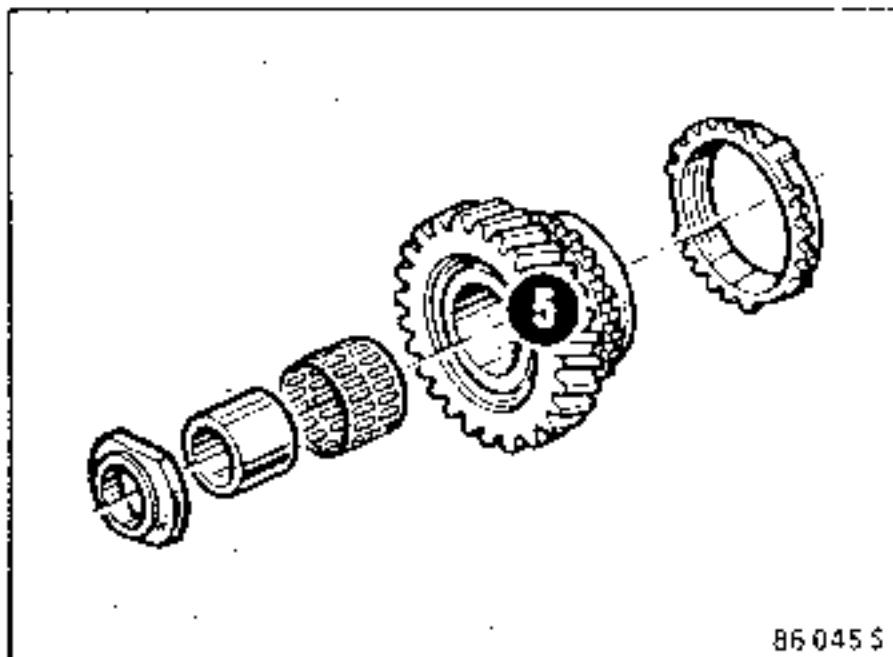

*On the secondary shaft :*

Remove the shouldered washer (64).

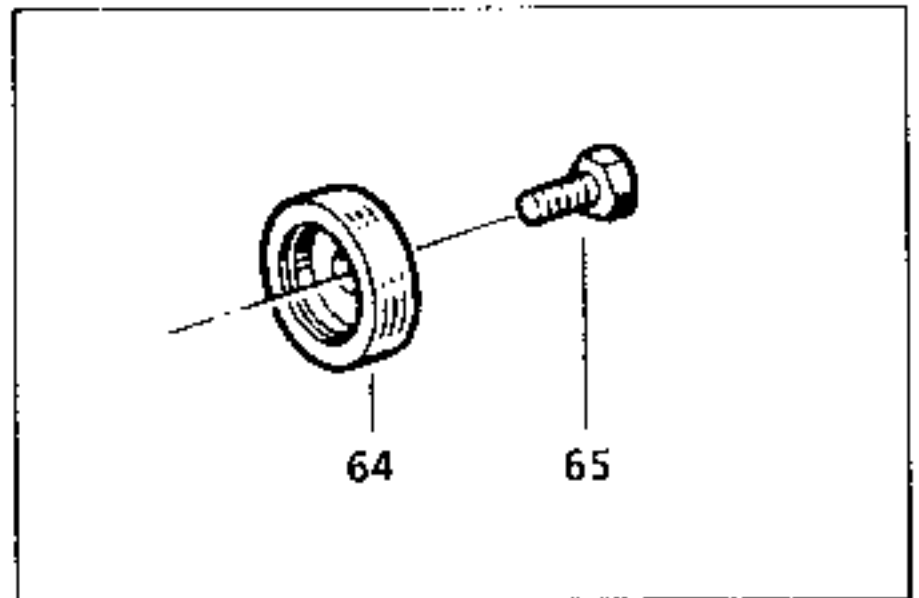

Extract the 5th gear fixed gear.

Two possibilities :

1. Use tool B.Vi. 28-01 fitted with claws B.Vi. 1007.

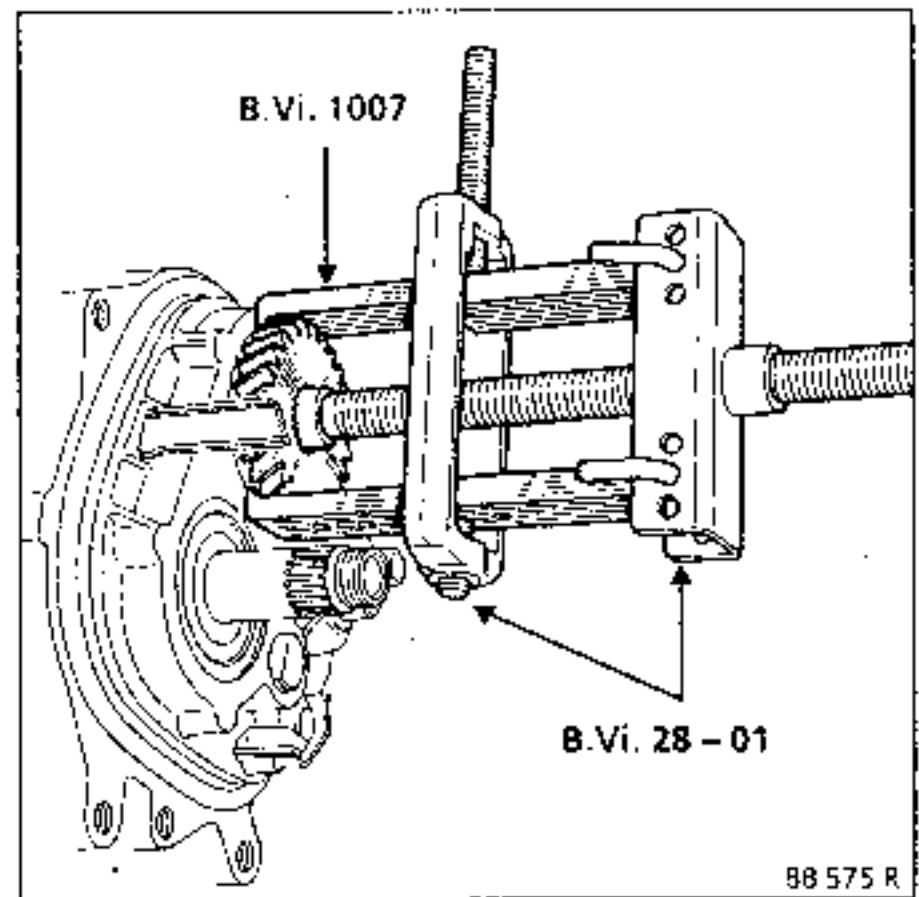

2. Using tools B.Vi. 22-01 and B.Vi. 1000

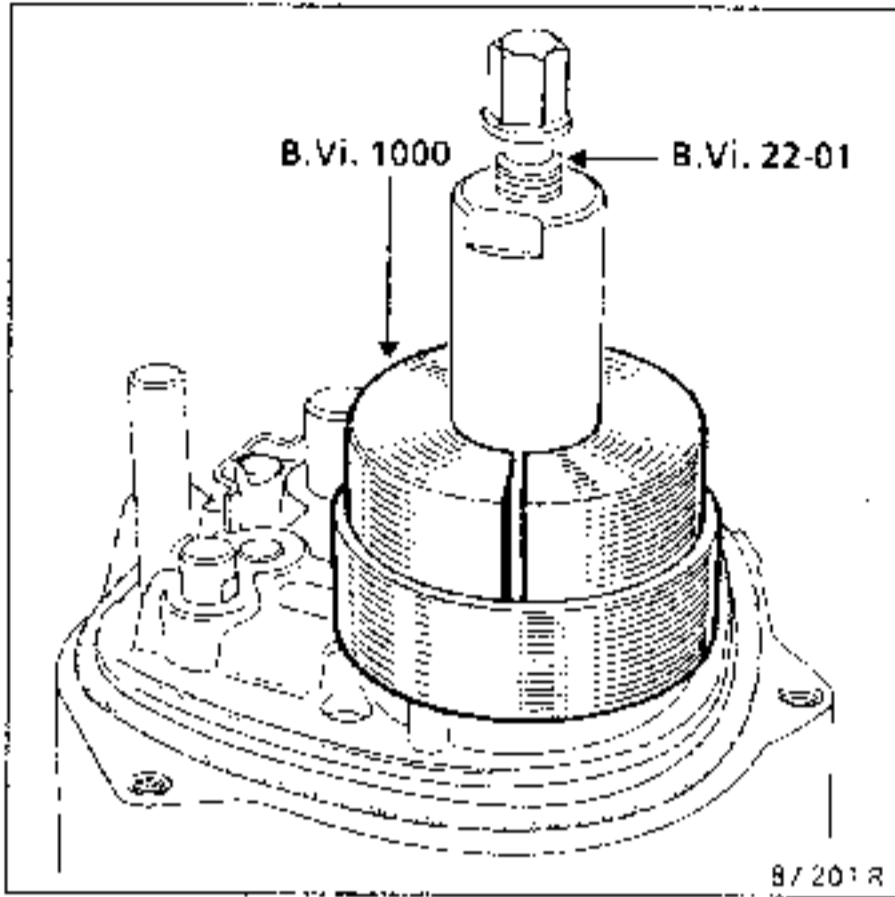

REFITTING

*On the secondary shaft :*

Apply 3 drops of Loctite FRENBLOC to the fixed gear splines.

Refit the gear using tool B.Vi. 1175 and the shouldered washer (64).

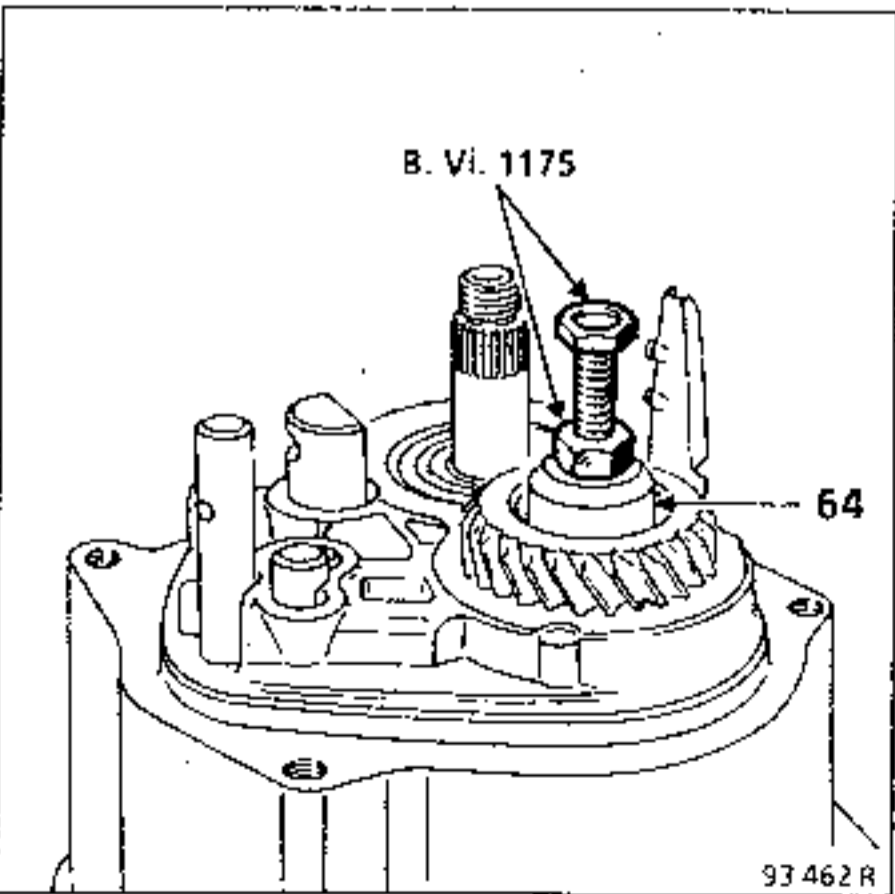

Remove tool B.Vi. 1175.

*On the primary shaft :*

Refit in the order (21) (shoulder next to bearing) (22), (23), (24) then (8)

Fit the fork on the sliding gear (26) fitted with (25)

Apply 3 drops of Loctite FRENBLOC to the hub and replace the hub - sliding gear and fork assembly.

Ensure the synchro ring lugs fit into the locations on the hub correctly.

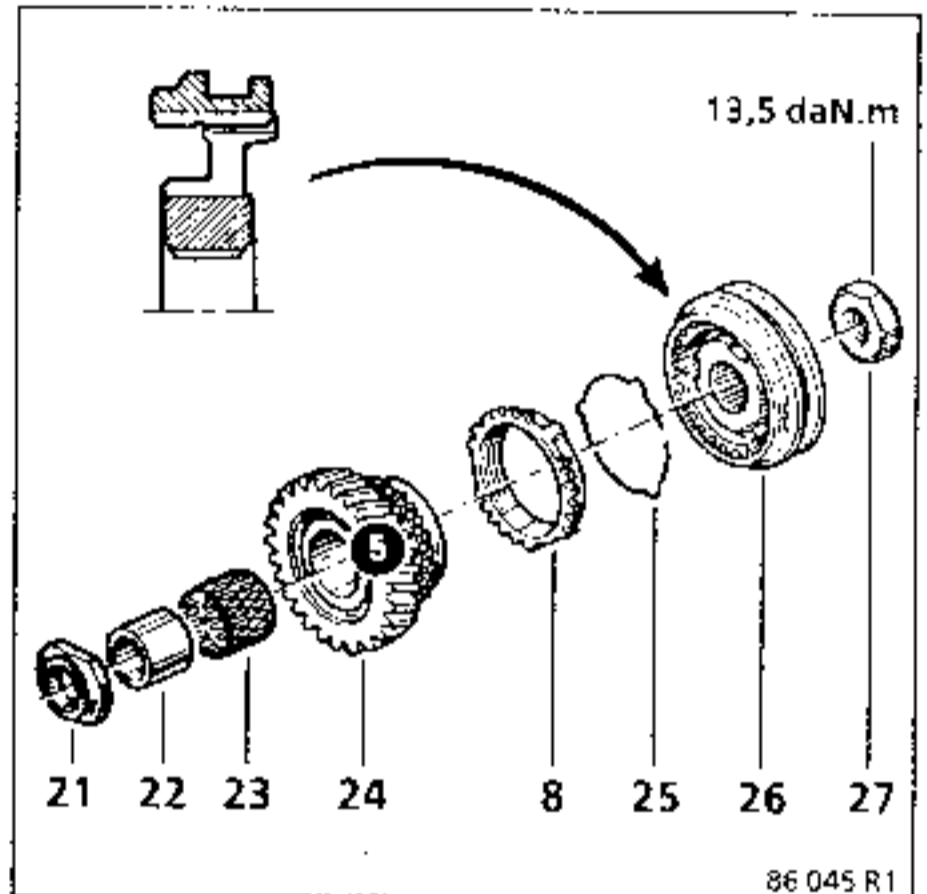

Select 1st gear with the gear lever and 5th gear in the gear box by sliding the 5th gear fork on its shaft.

*On the secondary shaft :*

Fit the shouldered washer (64)

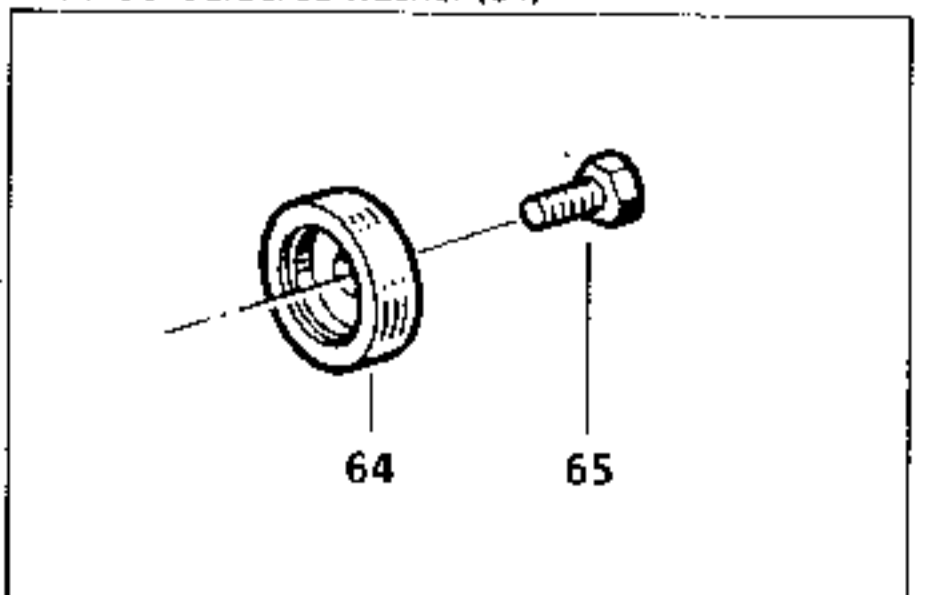

Apply 3 drops of **Loctite FRENBLOC** :

- to the nut (27) on the primary shaft and torque tighten to **13,5 daN.m**,
- to the bolt (65) and torque tighten to **8 daN.m**.

Fit a wooden block between the 5th gear fork and the drive gear to give support and fit a new roll pin to the 5th gear fork using tool **B.Vi. 31-01**. Ensure the pin is correctly fitted - the split should be aligned with the shafts.

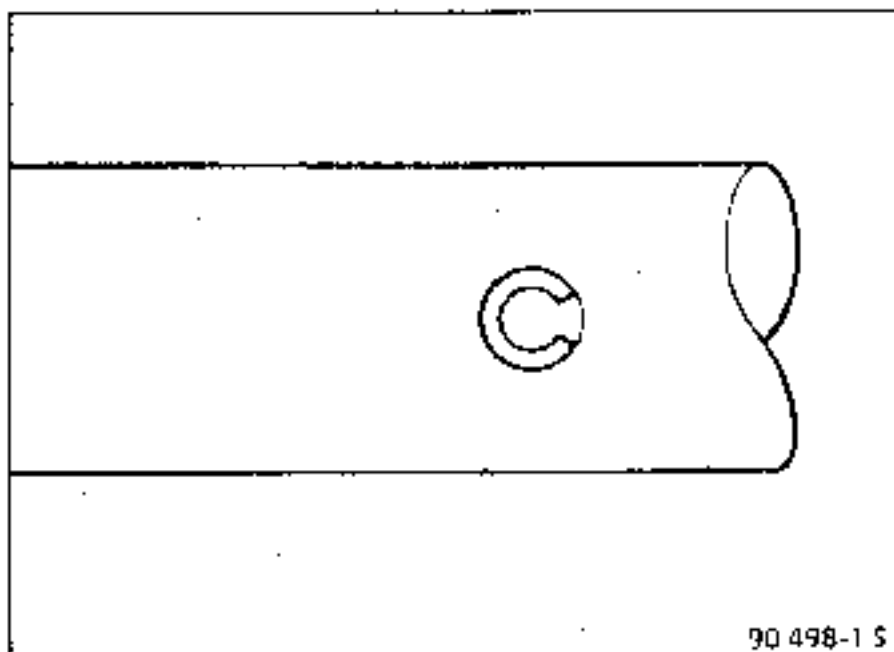
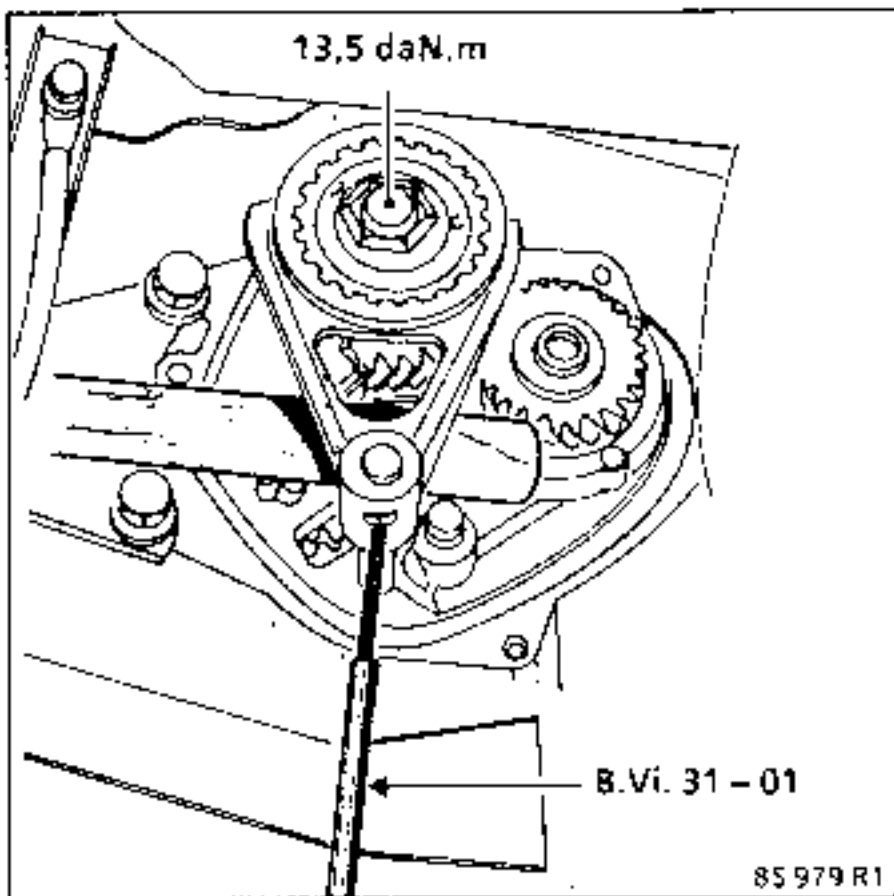

Return the gear box to neutral and check that all the gears can be engaged.

If there is a fault, check that reverse gear is not engaged.

Fit a new O ring to ensure the rear housing is sealed.

fit the rear housing by sliding tube (A) into the primary shaft and the lubricating nozzle into the oil feed channel (B). Torque tighten the bolts to **2,5 daN.m**.

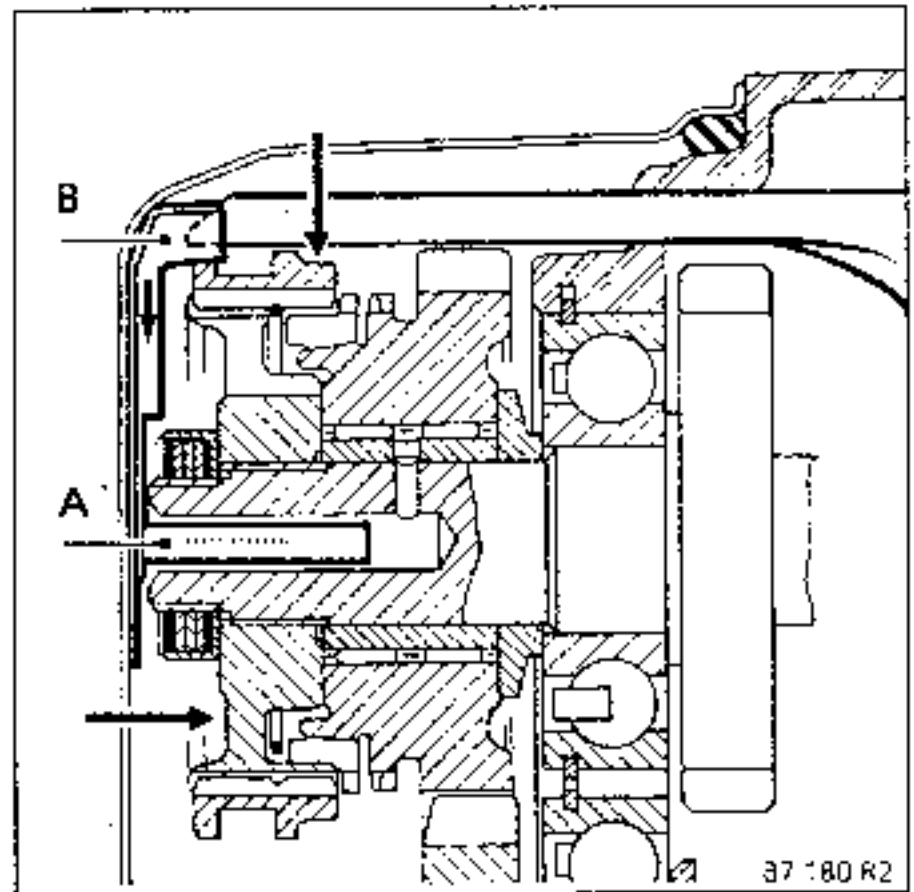

Fill the gear box with oil.

Check the rear housing is sealed.

Refit the engine undertray.

SPECIAL TOOLING REQUIRED	
B.Vi. 31-01	Set of pins
T.Av. 476	Ball joint extractor
B.Vi. 945	Differential seal fitting mandrel

TIGHTENING TORQUES (in daN.m)	
Brake caliper mounting bolts	10
Shock absorber base mounting bolts	11
Track rod end	3,5
Wheel bolts	9

CONSUMABLES
Loctite FRENBLOC : Brake caliper mounting bolts
CAF 4/60 THIXO : Ends of drive shaft roll pins
MOLYKOTE BR2 : Right hand sunwheel splines

**REMOVAL**

Drain the gear box.

Fit axle stands at the front of the vehicle, under the side in question

Remove the wheel.

Remove the drive shaft roll pins using tool B.Vi. 31-01

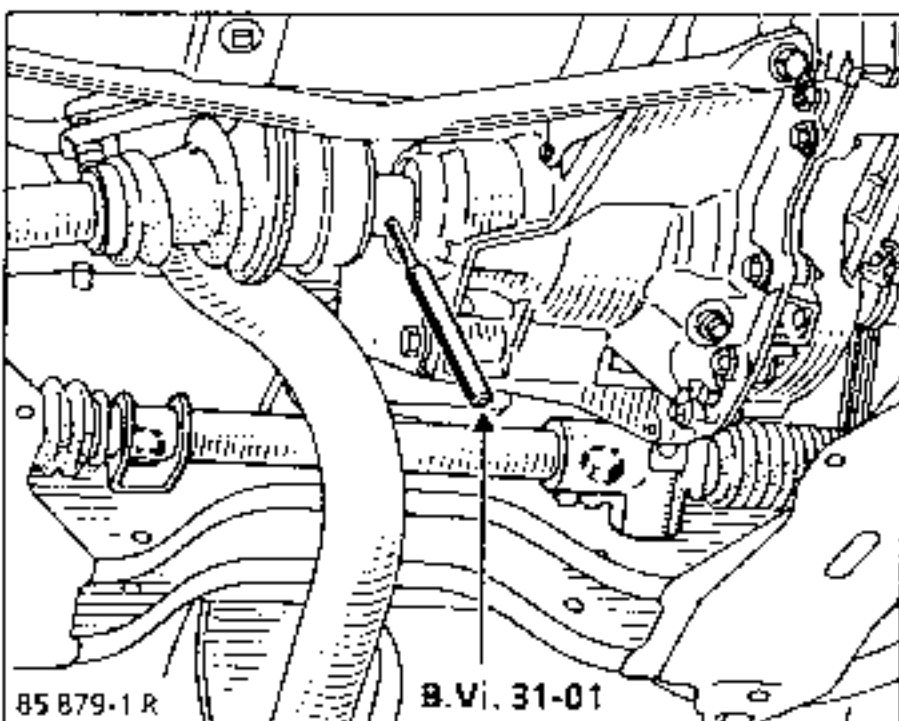

Remove:

- the track rod end (tool T.Av. 476),

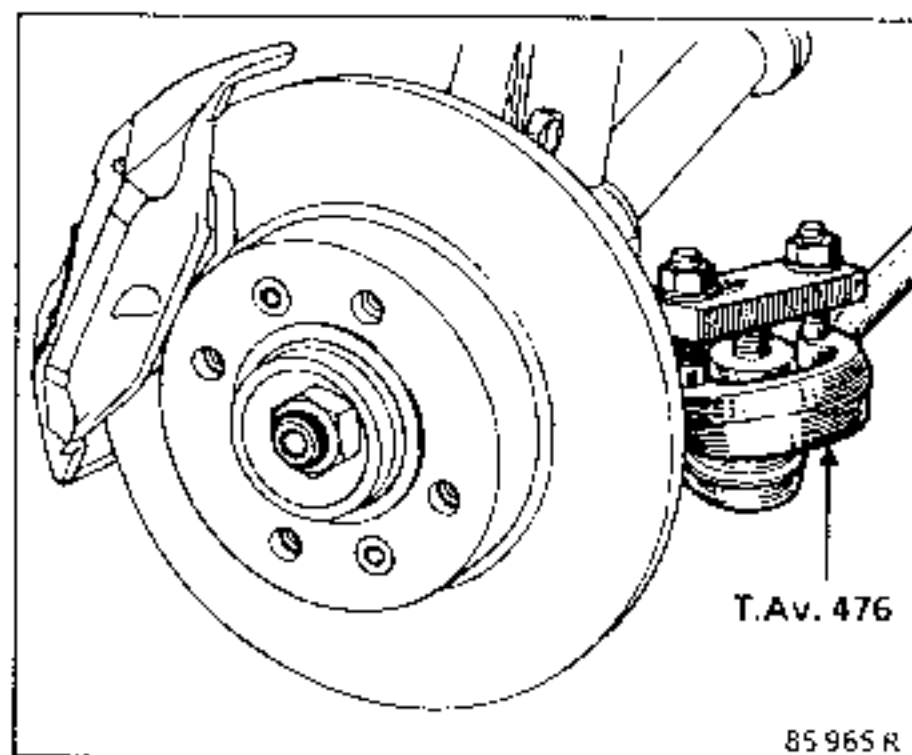



– the two brake assembly mounting bolts (A)

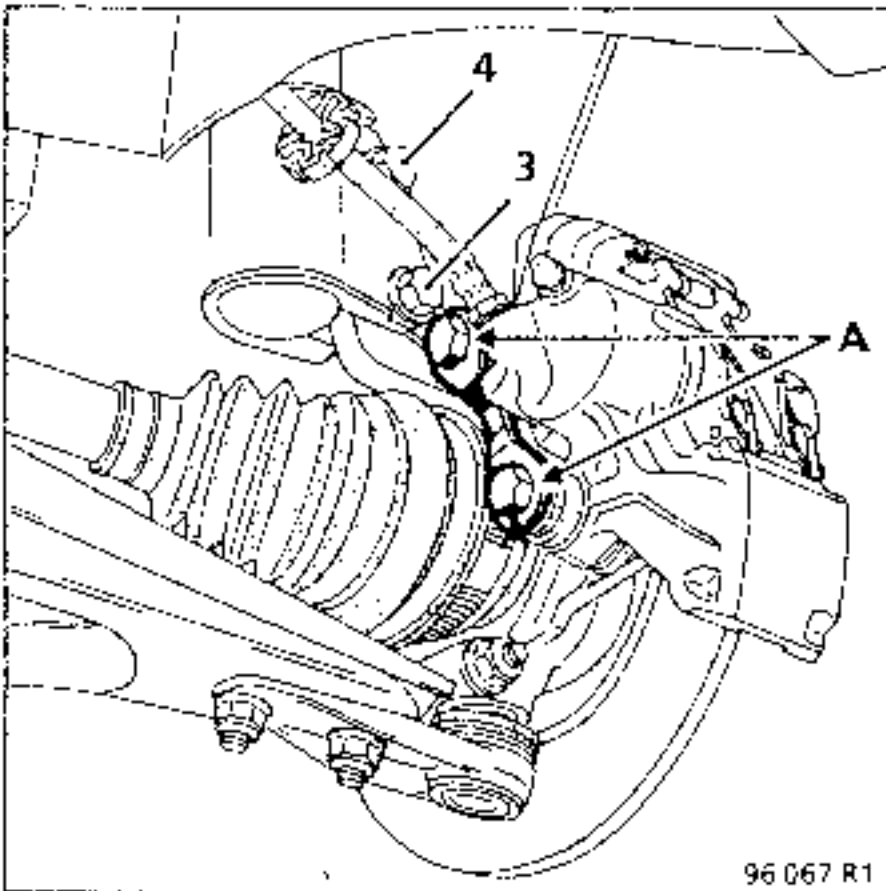

Attach the brake caliper to the suspension spring in order to avoid damaging the brake pipe.

Undo the lower shock absorber base mounting bolt (3) and remove the upper bolt (4).

Tip the stub axle carrier and remove the drive shaft (take care not to damage the gaiters during this operation).

Remove the O ring from the sunwheel

Tap the lip seal on its base using a roll pin punch and a small hammer to make it twist

When the seal is released, remove it using a pair of pliers. Take care not to damage the sunwheel splines

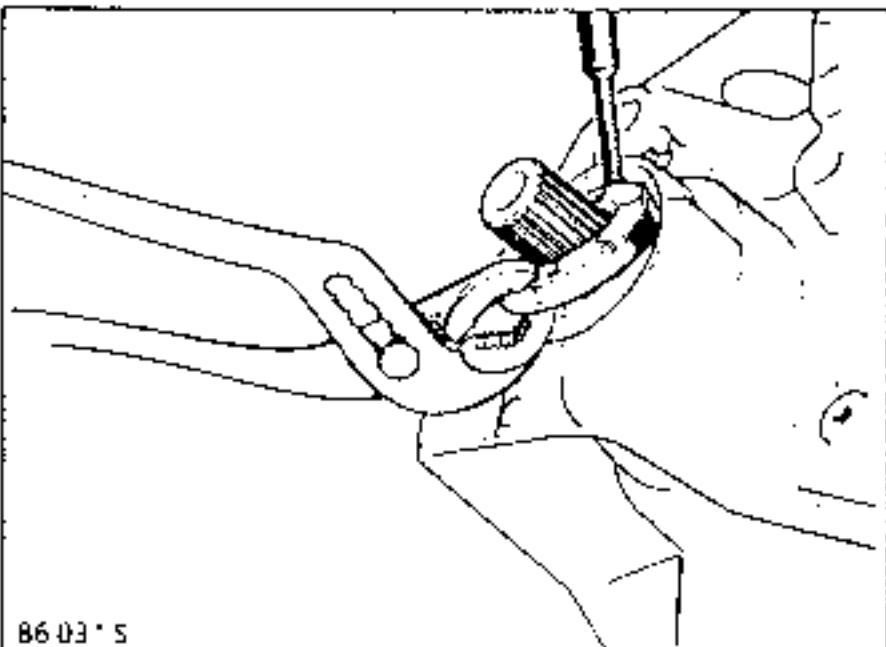

## REFITTING

The seal is refitted using tool B.Vi. 945, which includes :

- a seal protector (A),
- a seal fitting tool (B)

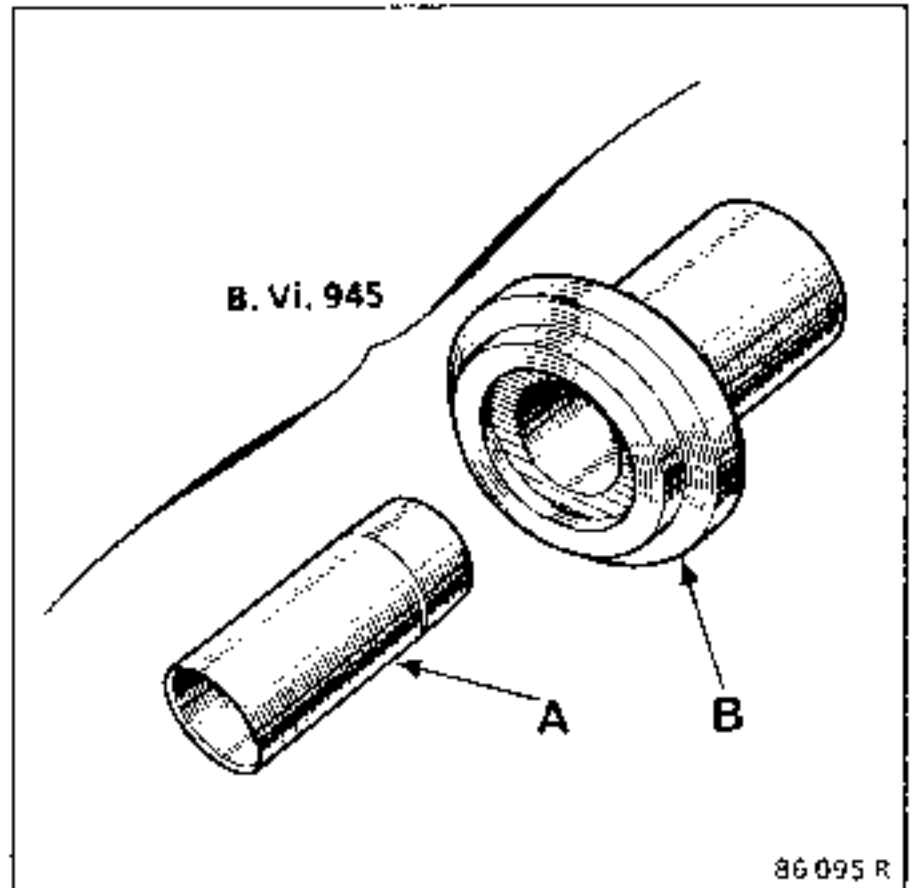

## METHOD

Fit the oiled protector (A) on the sunwheel and fit the oiled seal (C) using tool (B).

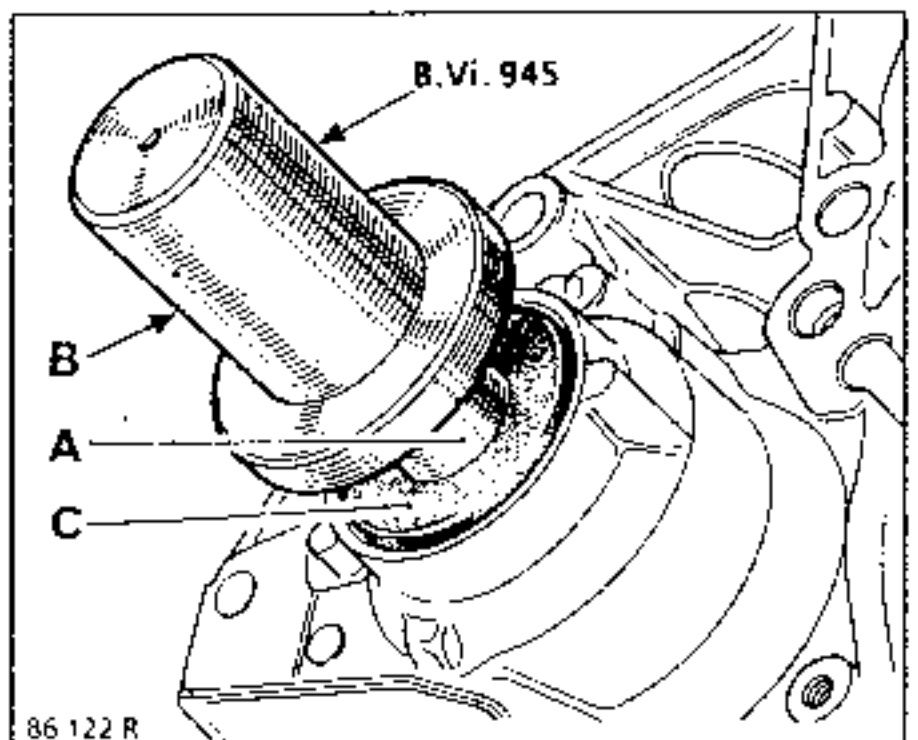

Fit the O ring on the sunwheel and coat the splines with **MOLYKOTE BR2** grease.

Position the drive shaft in relation to the sunwheel.

Tilt the stub axle carrier to fit the driveshaft onto the sunwheel, using pin **B.Vi. 31-01** to align the holes.

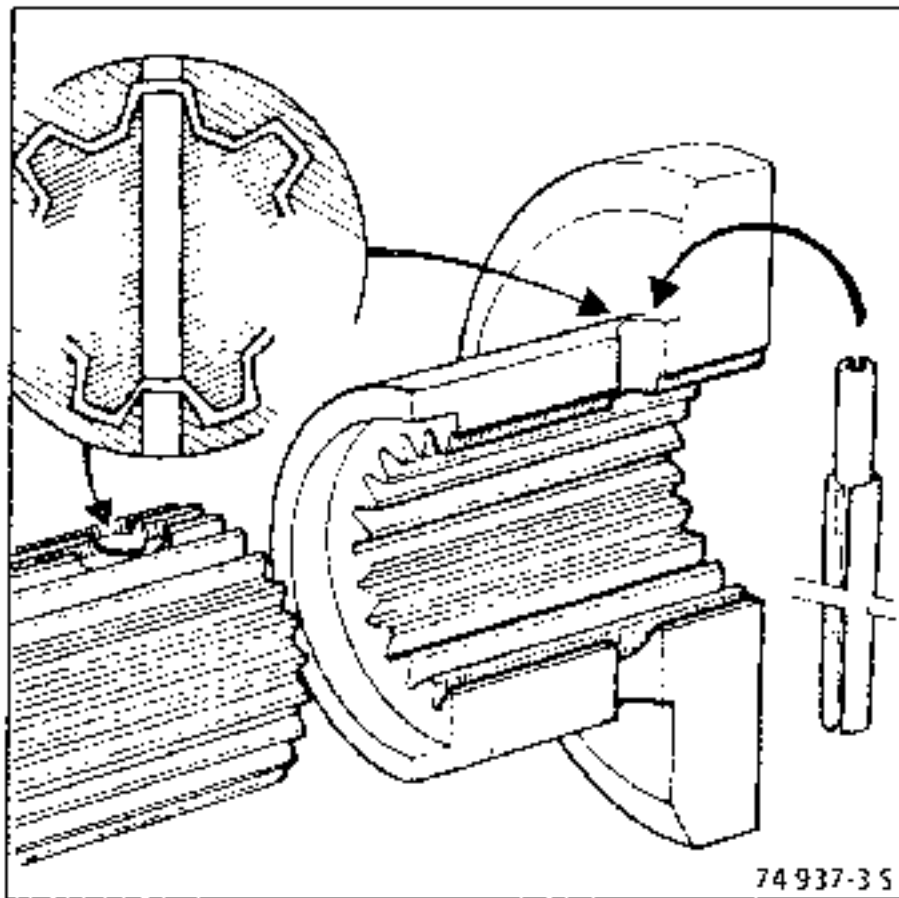

Fit new roll pins and seal the ends (**CAF 4/60 THIXO**).



Tighten all bolts to the recommended torque.

Refit the brake caliper and coat the bolts with **Loctite FRENBLOC**.

Refill the gear box.

**REPLACEMENT**

**1st case :**  
Only the speedometer gear or the shaft is damaged

**REMOVAL**

The gear box does not need to be completely removed

Disconnect the speedometer drive cable

Remove pin (E) and disconnect the cable from the gear box.

Remove the gear from its position using the pliers.

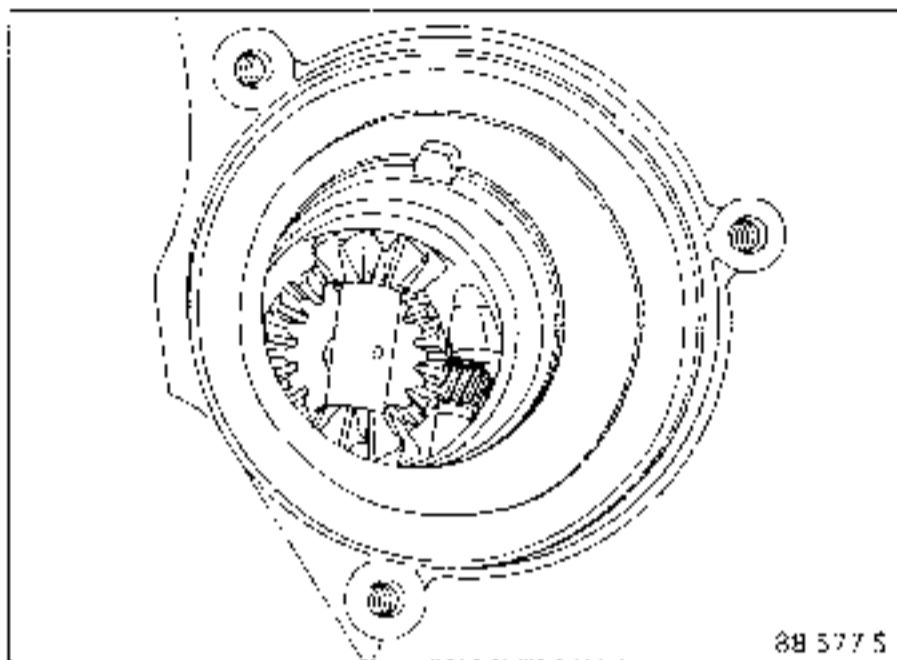

**NOTE :** The gear and the shaft should be replaced with new parts when refitting.

**REFITTING**

Ensure the gear is fitted correctly.

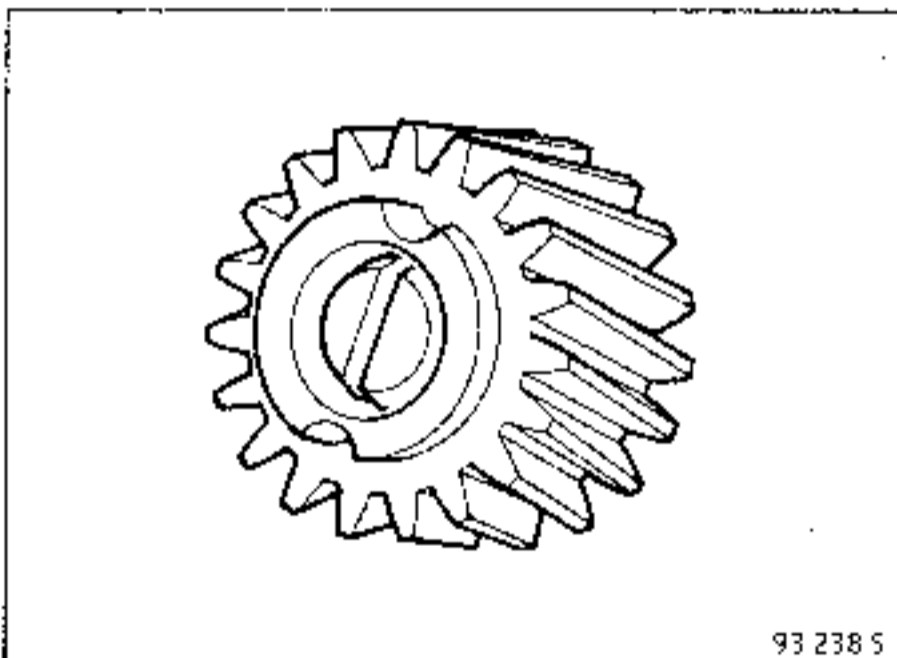

Ensure the assembly is correctly clipped into place.

Refit the sunwheel spider.

**2nd case :**

The gear and the speedometer crown wheel are damaged

The gear box must be removed and then the final drive must be removed from the gear box.

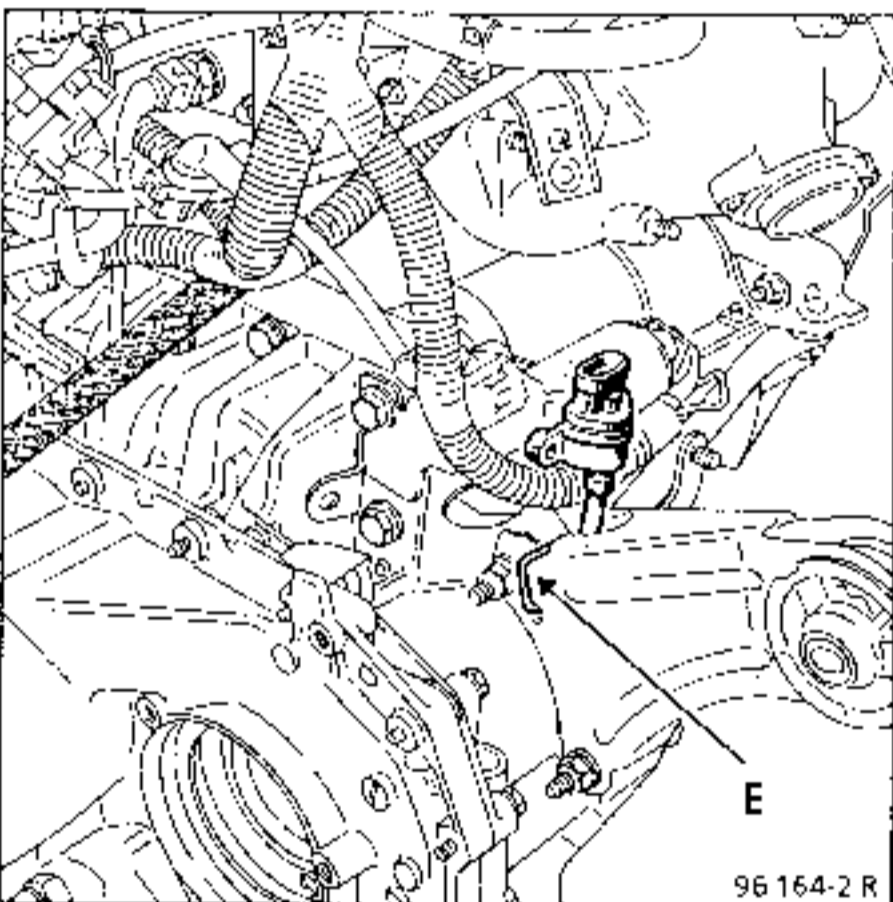

Uncouple the left hand drive shaft.

Remove the sunwheel spider.

Turn the drive shaft by hand so that the speedometer gear is accessible.

Unhook the shaft by using a pair of long nose pliers to pull it upwards.

Type	Quantity	Component concerned
Loctite SCELBLOC	Coat	Stub axle splines
CAF 4/60 THIXO	Coat	Gear box side drive shaft roll pins
MOLYKOTE BR2	Coat	Joint splines on gear box side
FRENBLOC	Coat	Brake caliper bolts
MOBIL CVJ 825 Black Star or MOBIL EXF 57C	320 g 130 g	GE 86 seal (Thermoplastic) GI 62 seal

SPECIAL TOOLING REQUIRED		
B.Vi.	31-01	Roll pin punch
Rou.	604-01	Hub locking tool
T.Av.	476	Ball joint extractor
T.Av.	602	Drive shaft pulling tool
T.Av.	1050	Drive shaft extractor

TIGHTENING TORQUES (in daN.m)		
Drive shaft nuts	25	
Mounting bolt for gaiter on gear box	2,5	
Wheel bolts	7,5	
Shock absorber base bolts	11	
Brake caliper mounting bolts	10	
Track rod end nuts	3,5	

**REMOVAL**

- Remove:
- the brake assembly (attach it to the chassis to ensure the brake pipe is not damaged),
  - the drive shaft nut : tool Rou. 604-01.

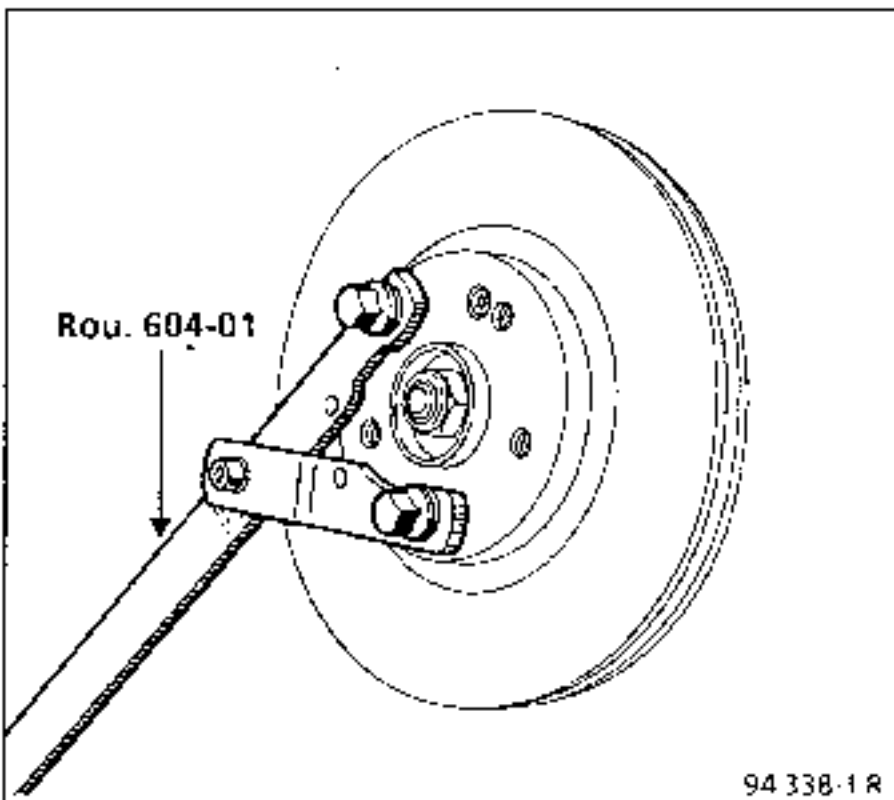

*From the left hand side :*

Drain the gear box.

Remove the three bolts.

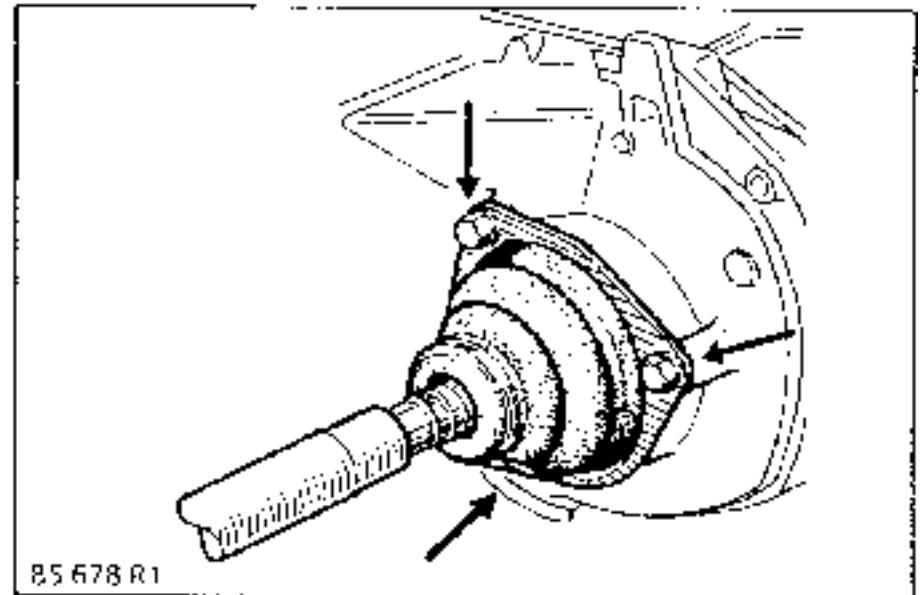

*From the right hand side :*

Remove the roll pin : tool B.Vi. 31-01

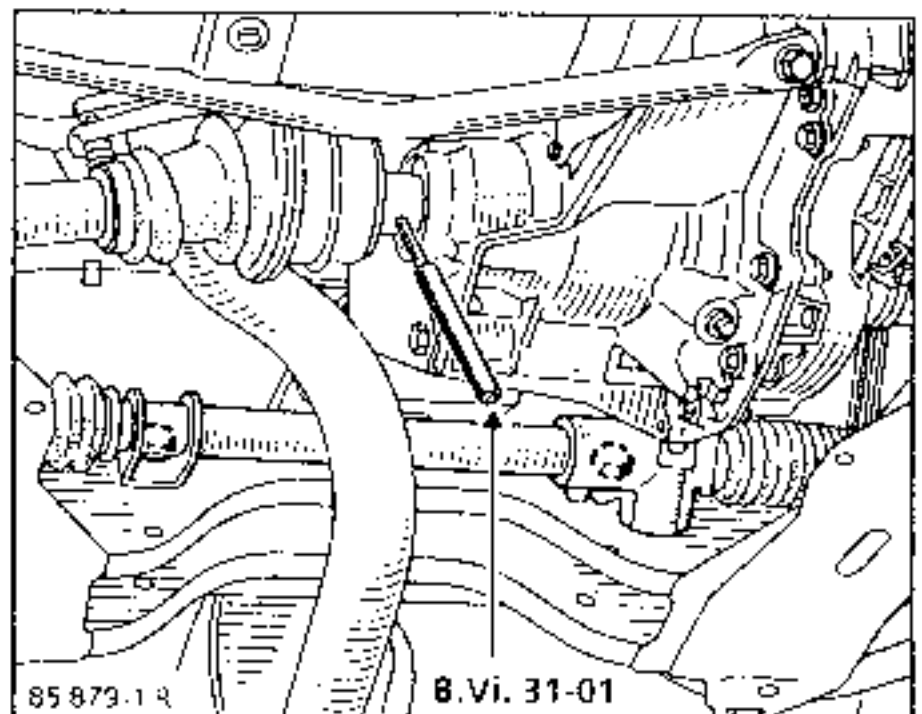

**On both sides :**

Remove:

- the track rod end nut : tool T.Av. 476.

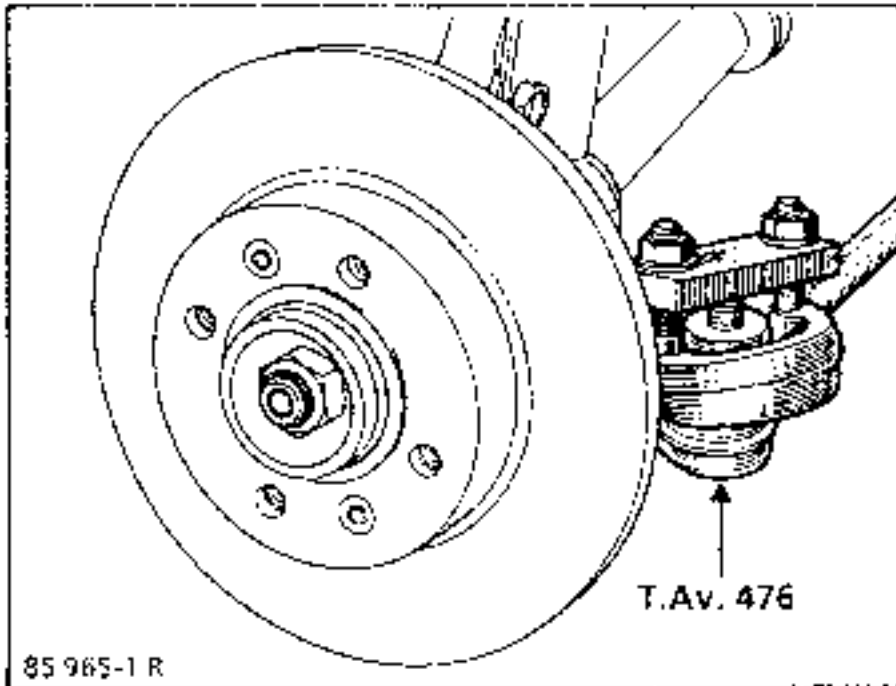

- the upper shock absorber base mounting bolt.

These vehicles are fitted with bonded drive shafts.  
Tool T.Av. 1050 is used to push them back.

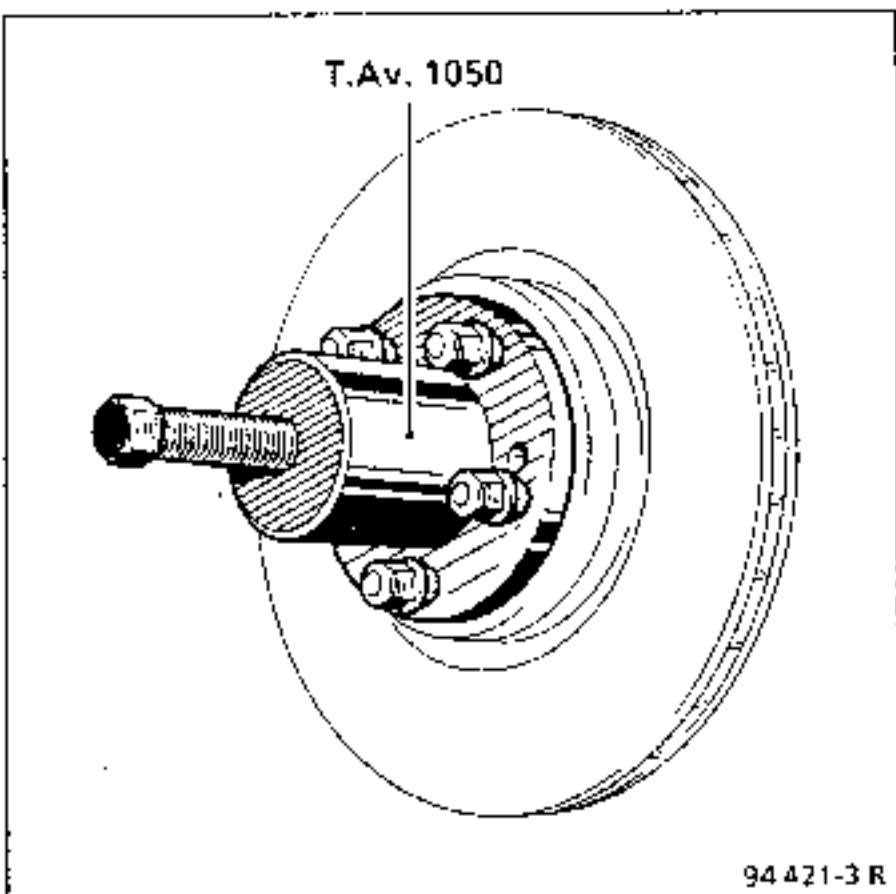

Remove the lower shock absorber base mounting bolt and extract the drive shaft.

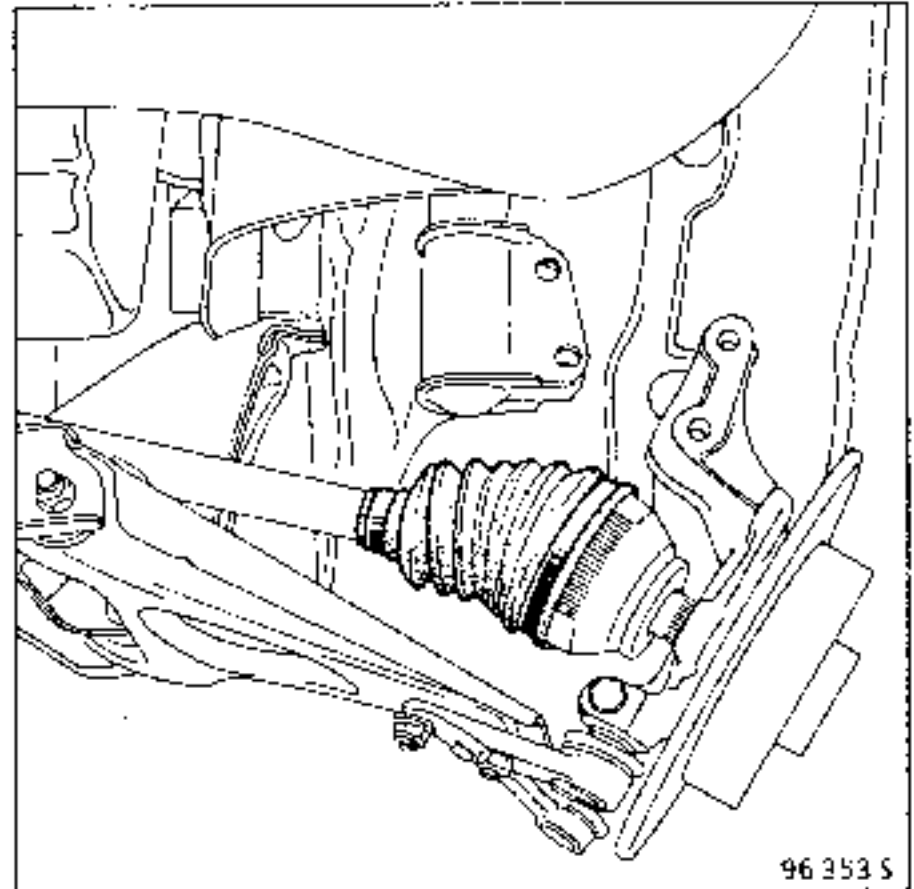

Take care not to damage the gaiters during this operation.

#### REFITTING

**NOTE :** drive shafts will be supplied from the Parts Department with a protector and fitting instructions. It is vital that these instructions are followed to ensure correct fitting with maximum **QUALITY**, as the slightest impact on the gaiters will cause the rubber to break sooner or later and the drive shaft will be damaged.

# CONSIGNES IMPERATIVES DE MONTAGE

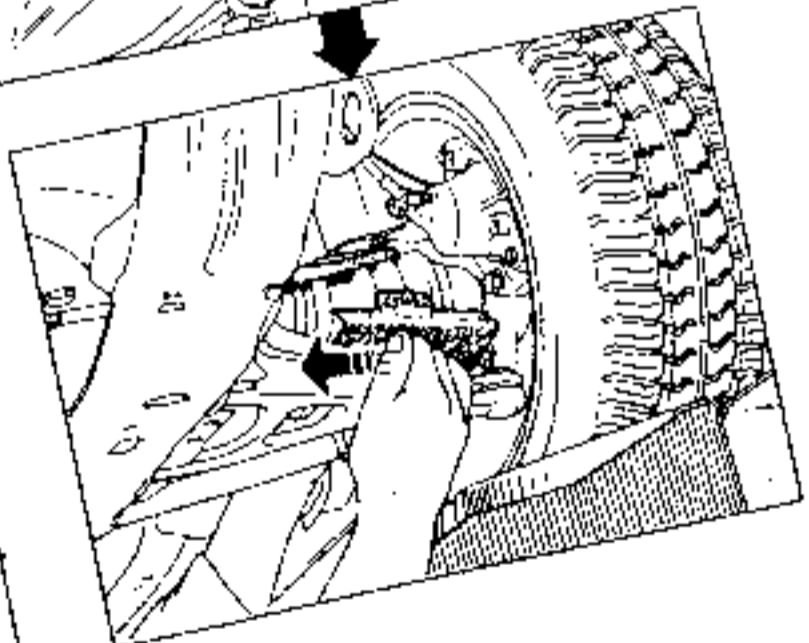
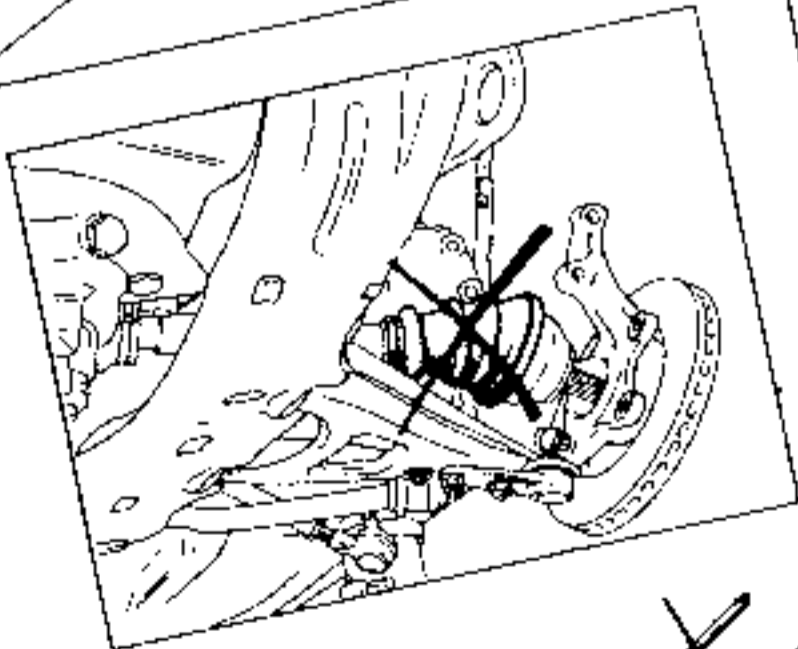
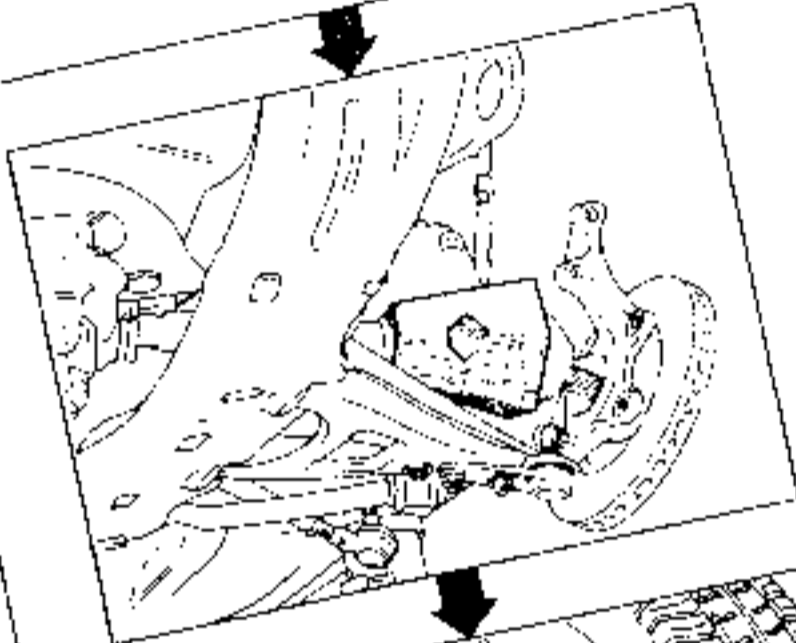
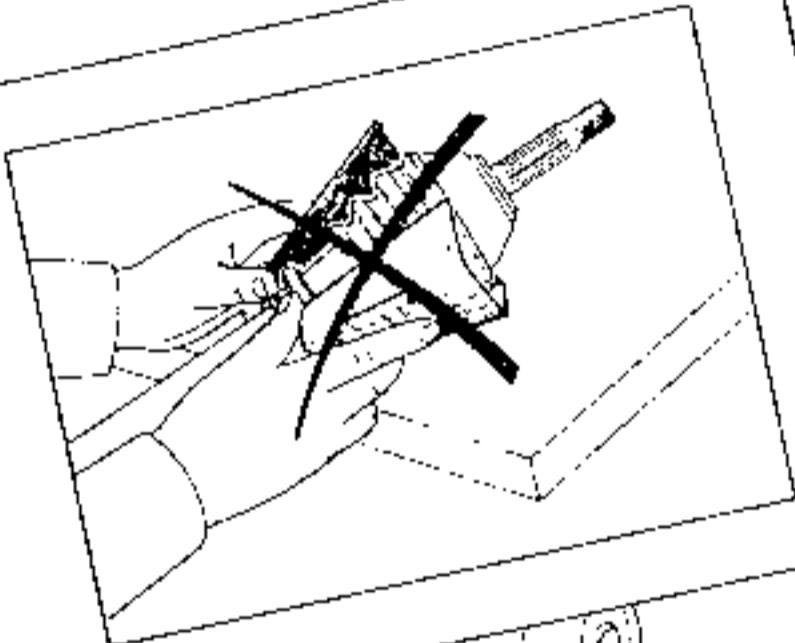
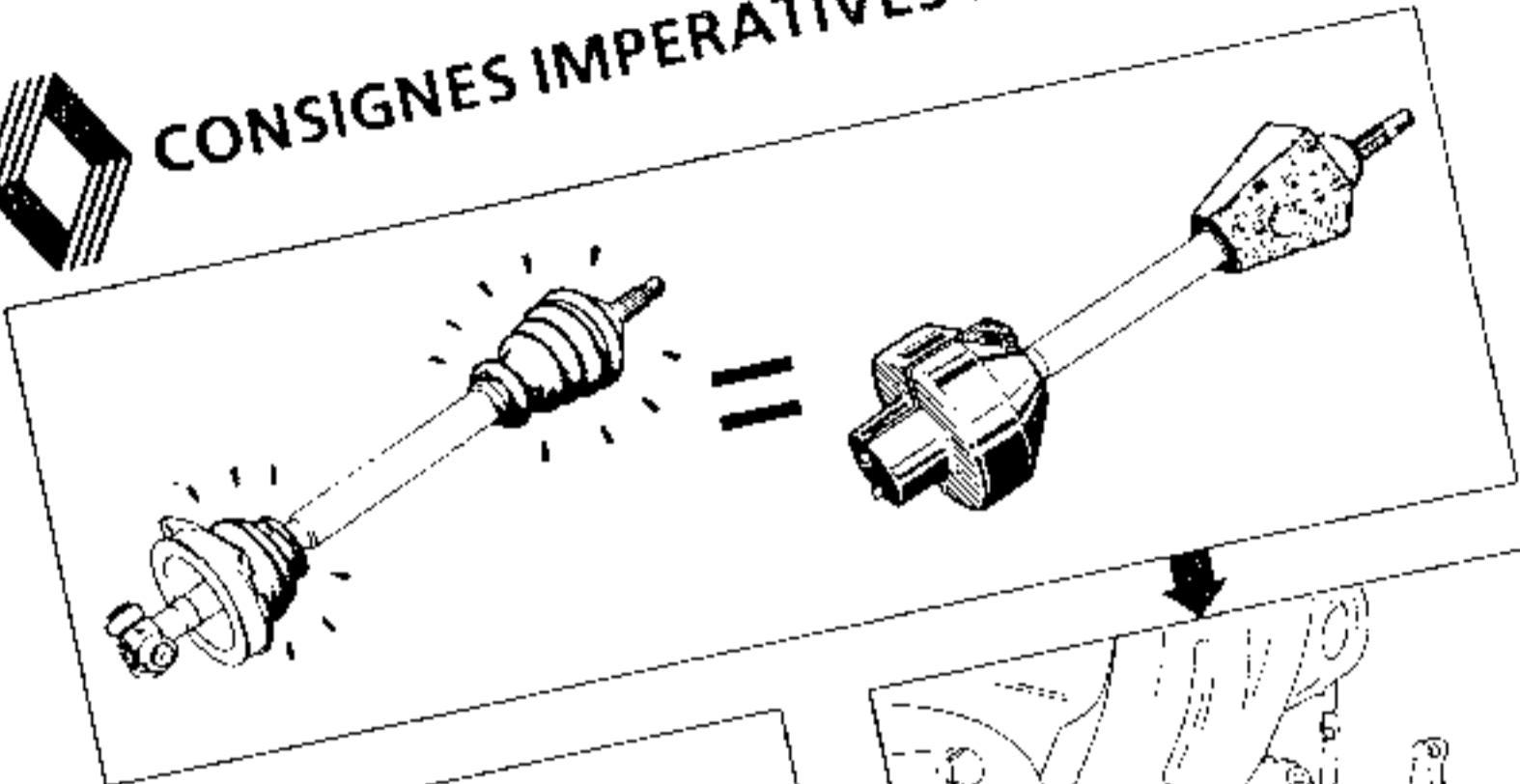

**RENAULT**

Never remove the cardboard protectors before completing the refitting of the drive shaft onto the vehicle.

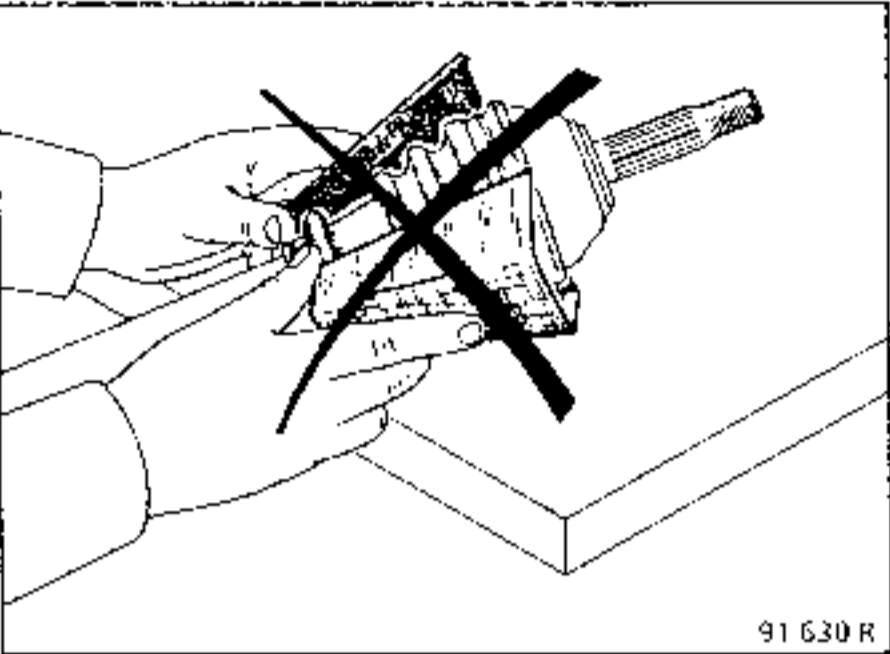

Never use a tool with a sharp edge which may damage the gaiters.

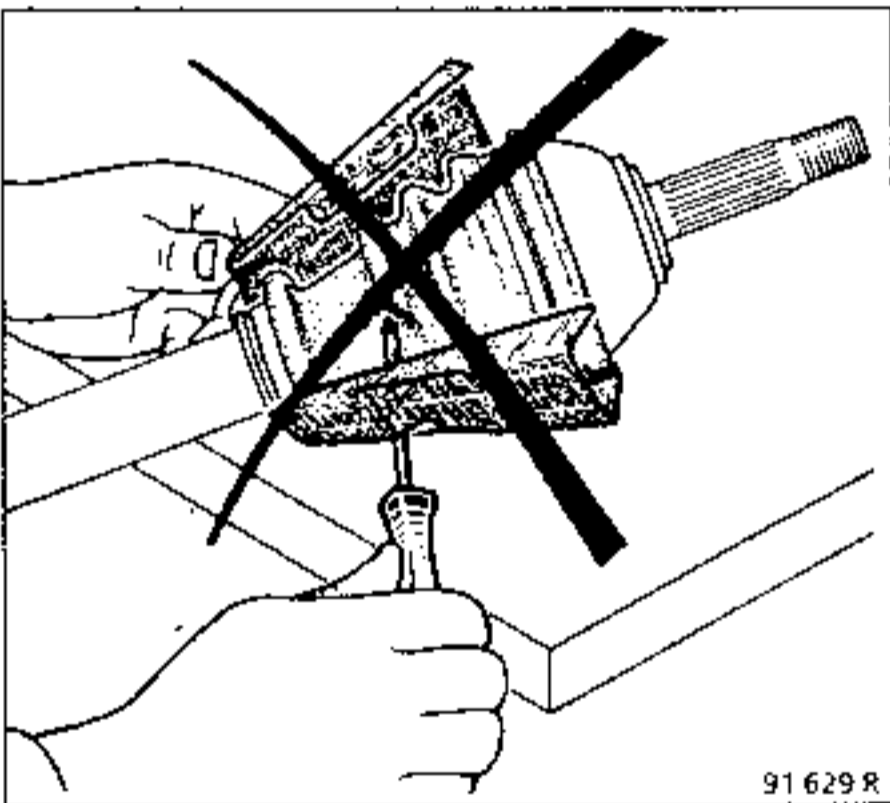

*On the left hand side :*  
Remove the plastic protector covering the bearing gaiter and fit the drive shaft as horizontally as possible.

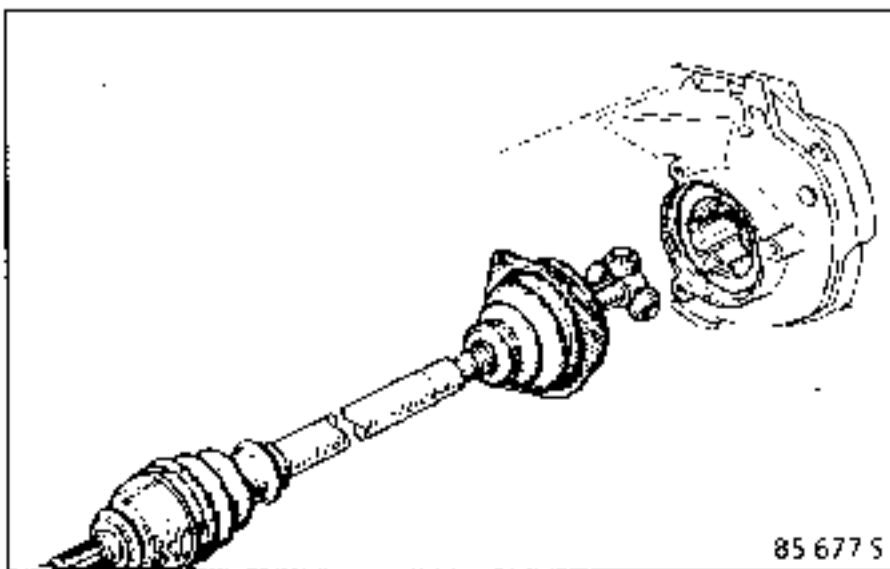

*On the right hand side :*

With the protector still in place, coat the splines of the joint on the gear box side with **MOLYKOTE BR2** grease.

Position the drive shaft in relation to the sunwheel and engage it

Check it is correctly positioned using the elbow pin of tool **B.Vi. 31-01**.

Fit the two new roll pins : tool **B.Vi. 31-01**. Seal the ends of the pins using **CAF 4/60 THIXO**.

**NOTE :** input chamfers on the sunwheels allow new roll pins to be fitted easily.

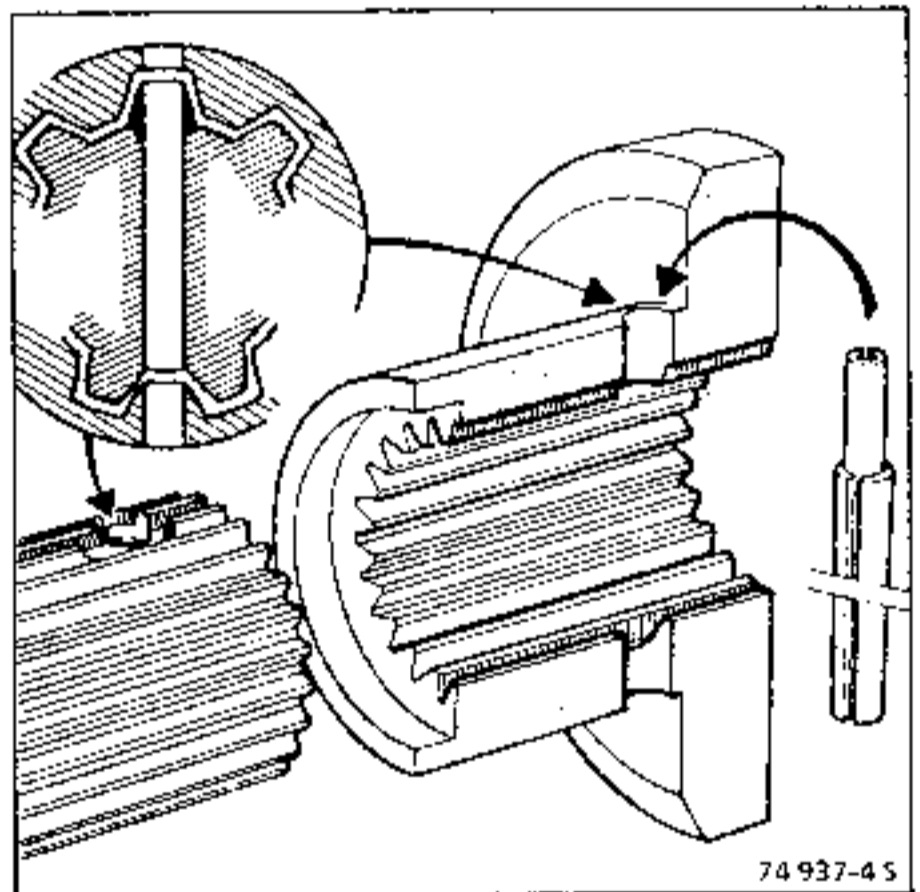



**On both sides :**

Coat the stub axle splines with Loctite  
SCELBLOC.

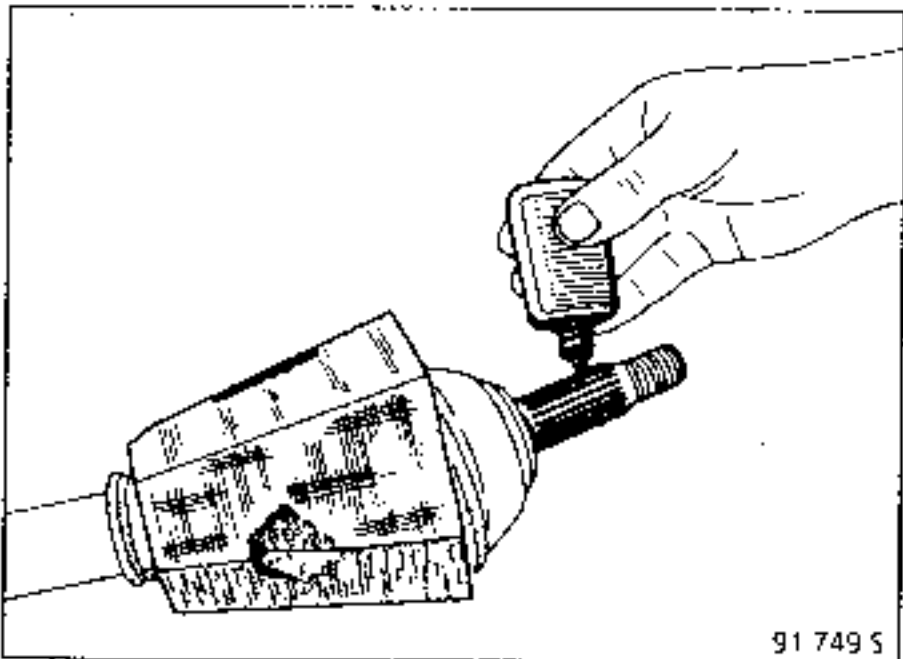

Fit the drive shaft stub axle in the hub.

It should slide in easily until it reaches the thread  
for the stub axle nut.

If this operation is difficult, use tool T.Av. 602.

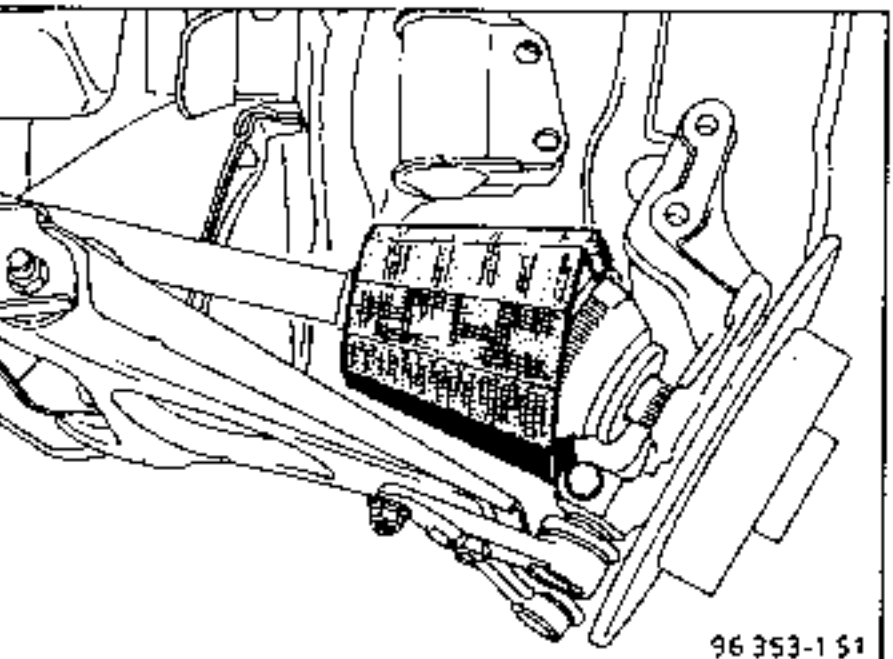
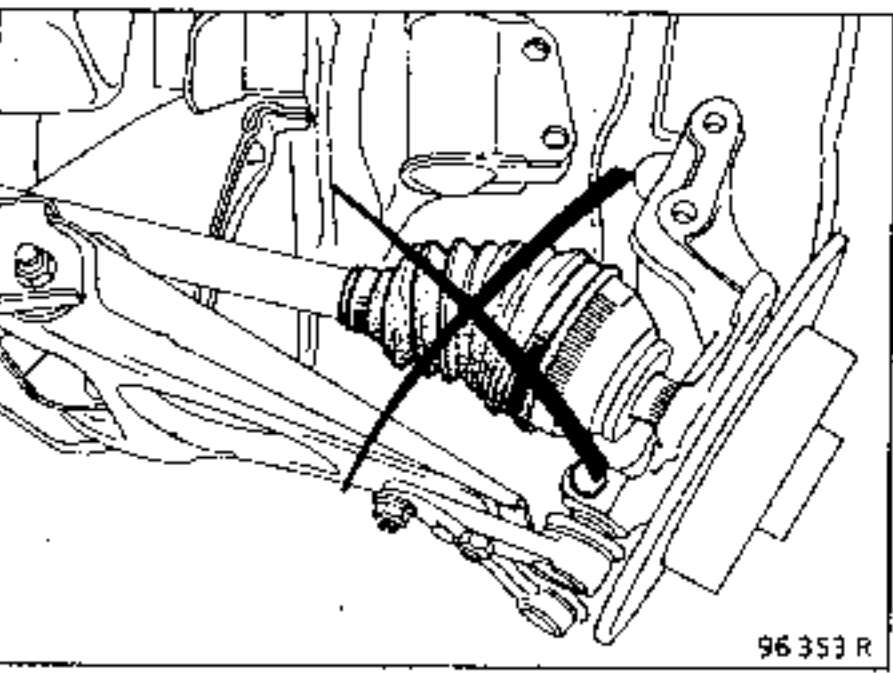

**Refit :**

- the two shock absorber base mounting bolts  
on the stub axle carrier and torque tighten,
- the track rod end - torque tighten the nut.

Torque tighten the drive shaft nut using tool Rou.  
604-01.

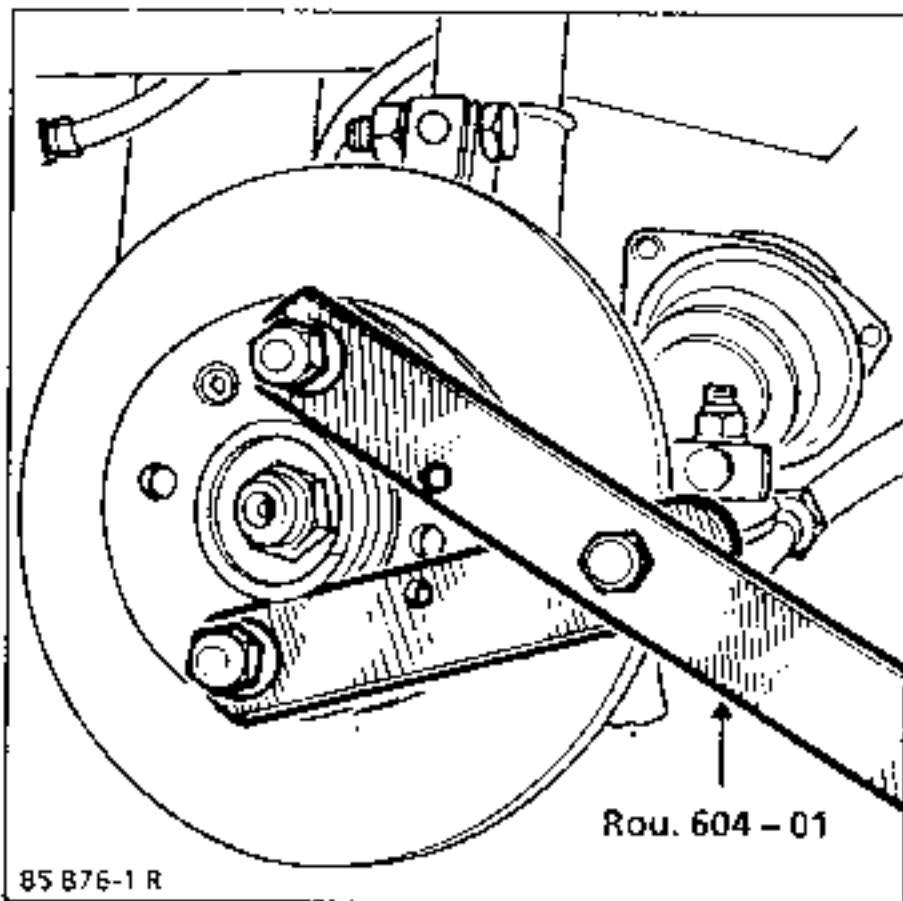

**On the left hand side :**

Clean the gaiter surface in contact with the gear  
box, refit the gaiter and the plate.

Align the gaiter as horizontally as possible and  
torque tighten the three bolts.

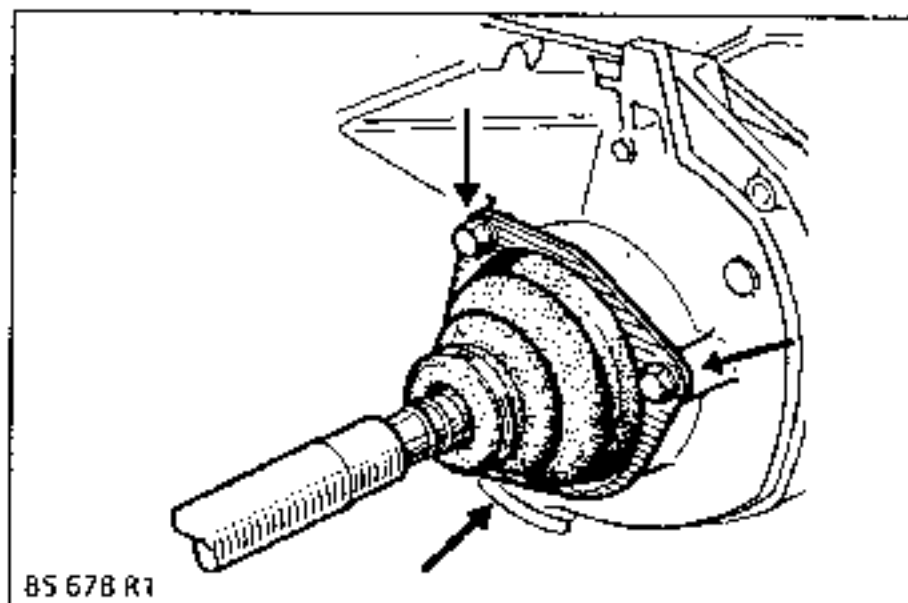

**On both sides :**

Refit the brake calipers, coat the mounting bolts with Loctite FRENBLOC and torque tighten.

Refit the wheels and lower the vehicle

When the vehicle is on the ground, remove the cardboard protectors as shown in the diagram.

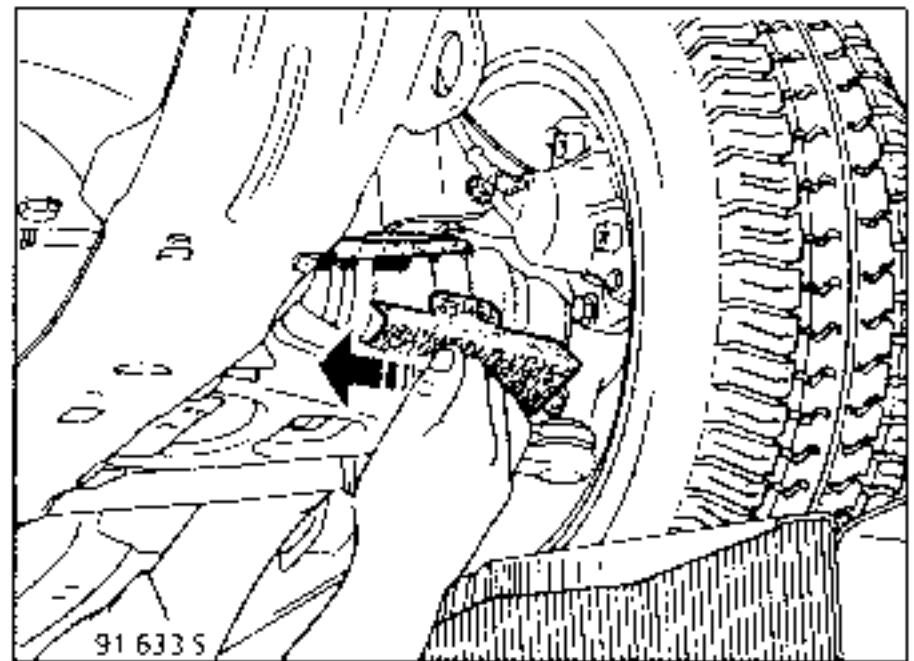
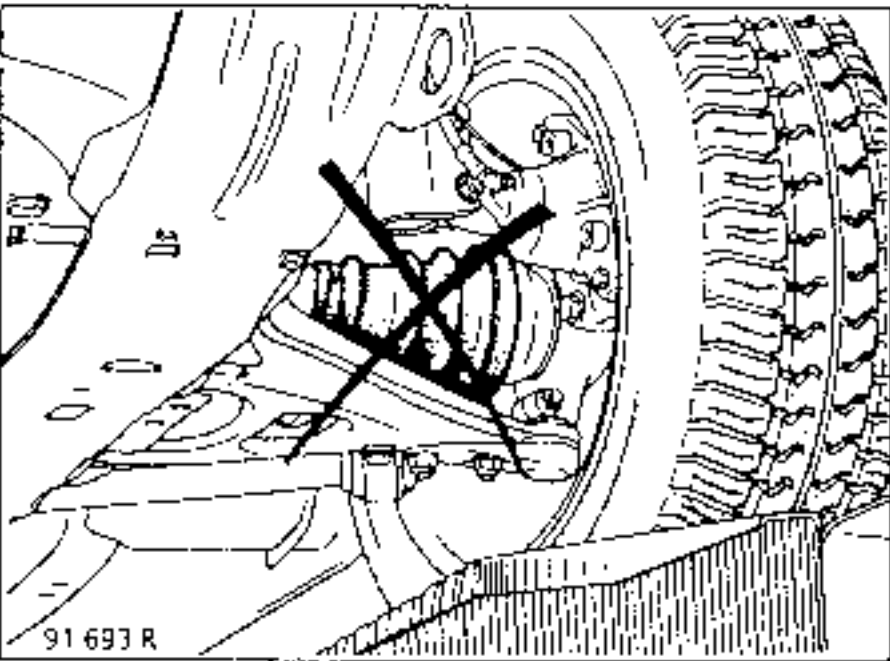

Never use a sharp tool which could damage the gaiter.

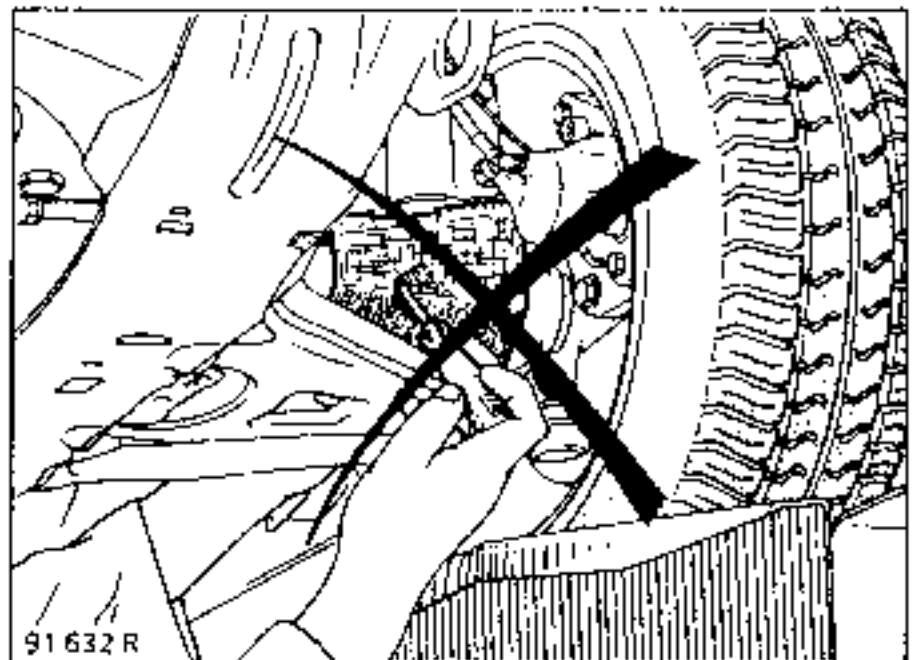
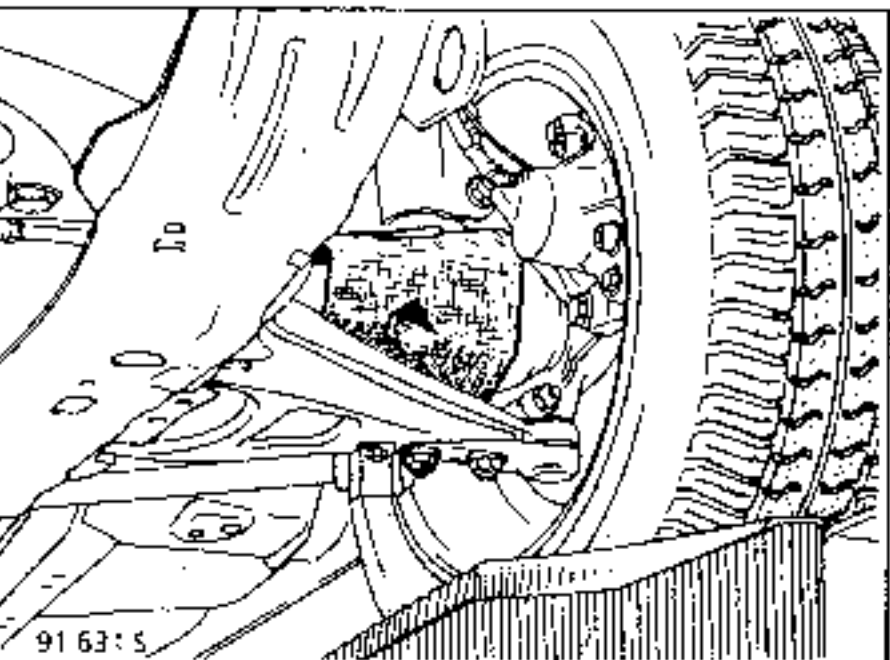

Press the brake pedal several times to bring the pistons into contact with the pads.

If the left hand drive shaft has been replaced, refill the gear box with oil.

SPECIAL TOOLING REQUIRED

T.Av. 1168 Click - collar pliers for thermoplastic drive shaft gaiter.

- 1 Stub axle cup
- 2 Retaining star
- 3 Spider
- 4 Yoke shaft
- 5 Retaining collar
- 6 Thermoplastic gaiter

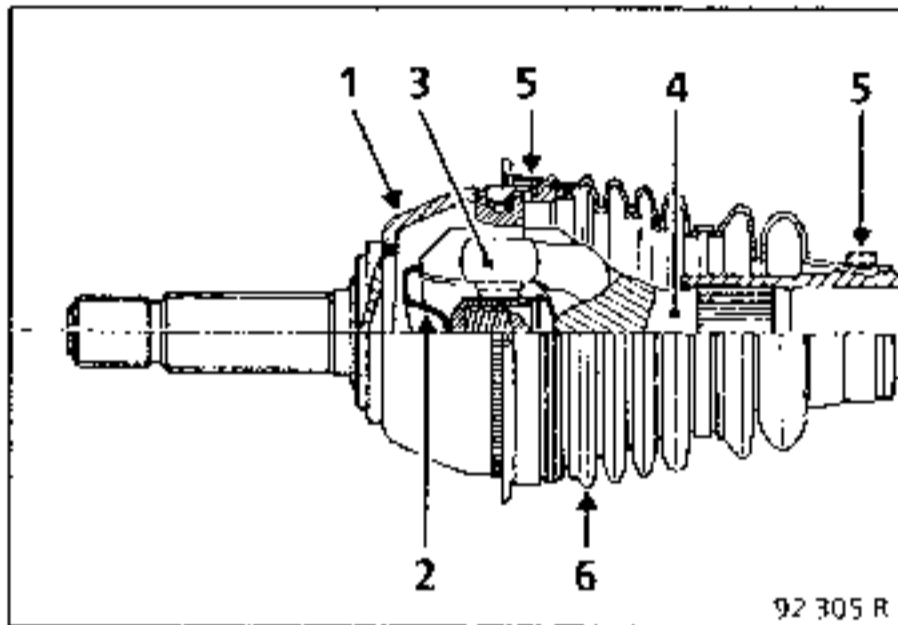

REMOVAL

Remove the gear box side gaiter as described below.

Unclip the small collar using tool T.Av. 1168.

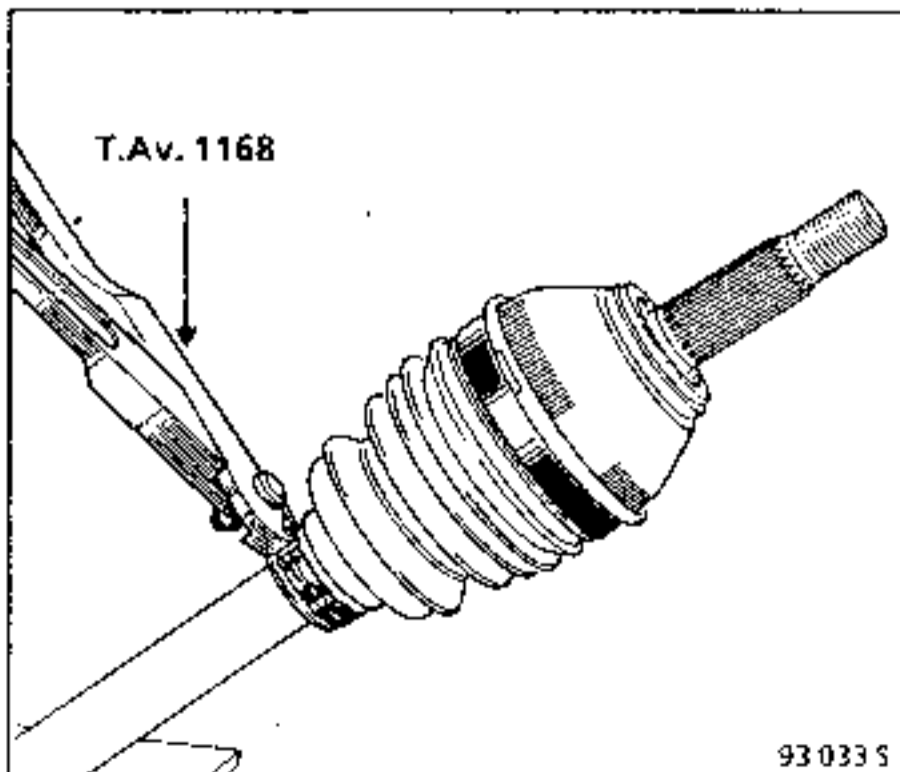

Saw off the large collar taking care not to damage the stub axle cup groove.

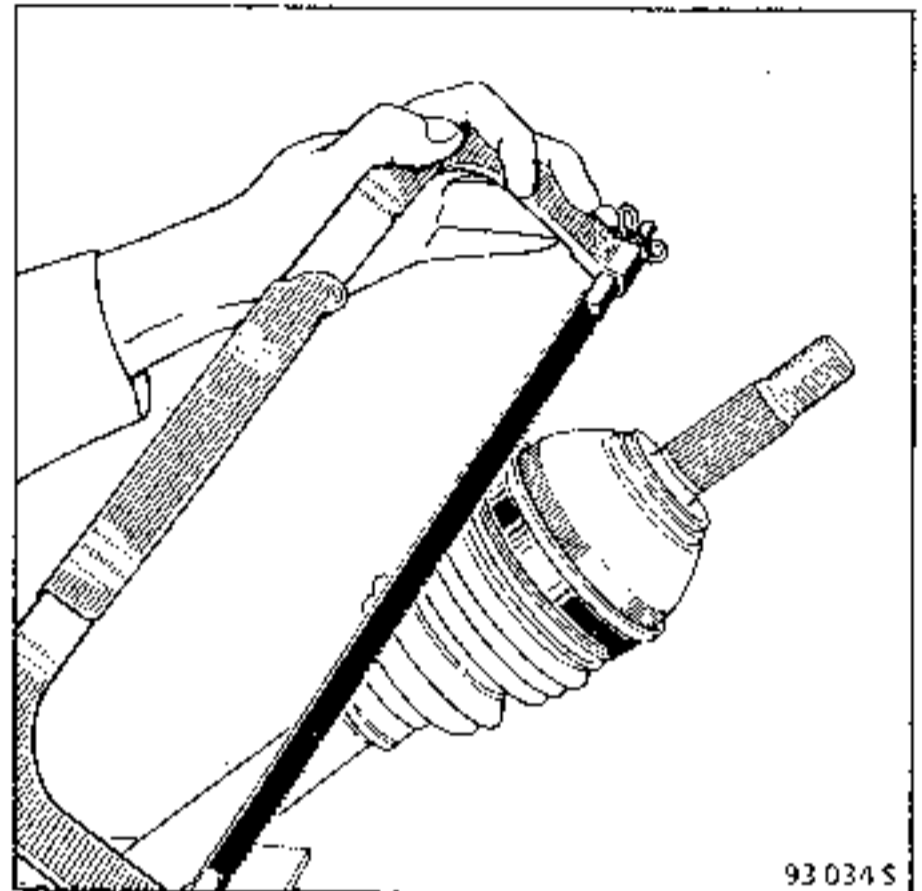

Cut the gaiter off.

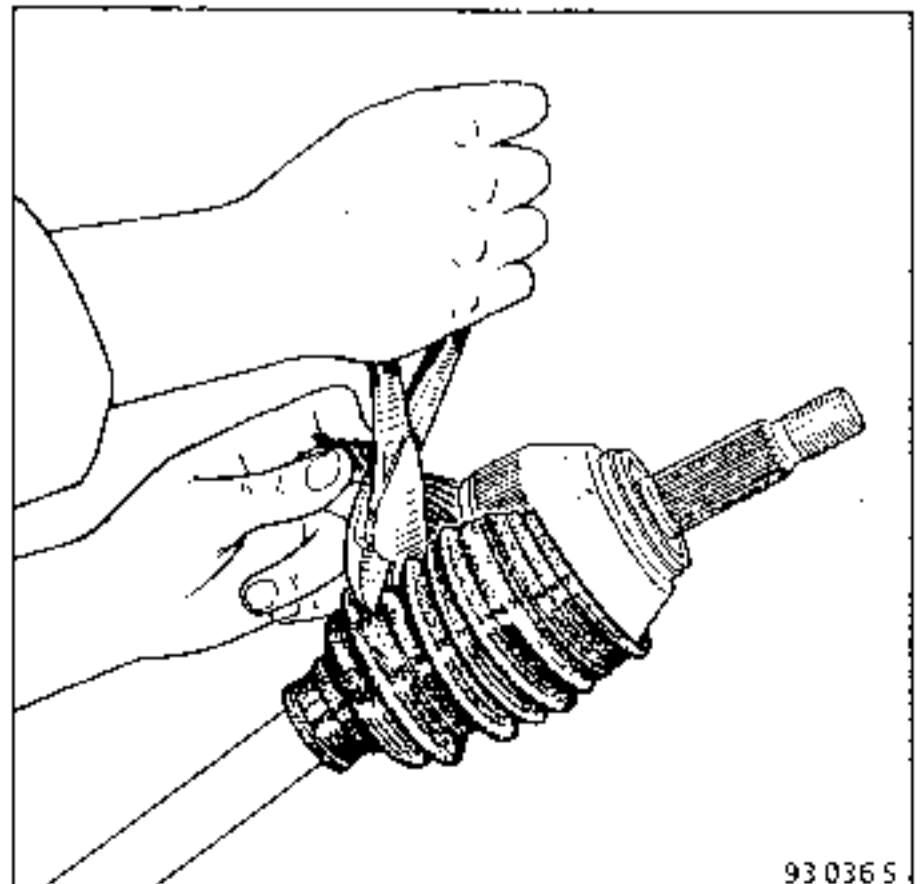

Remove as much grease as possible.

### REFITTING

Spread the grease dose between the gaiter and the stub axle cup.

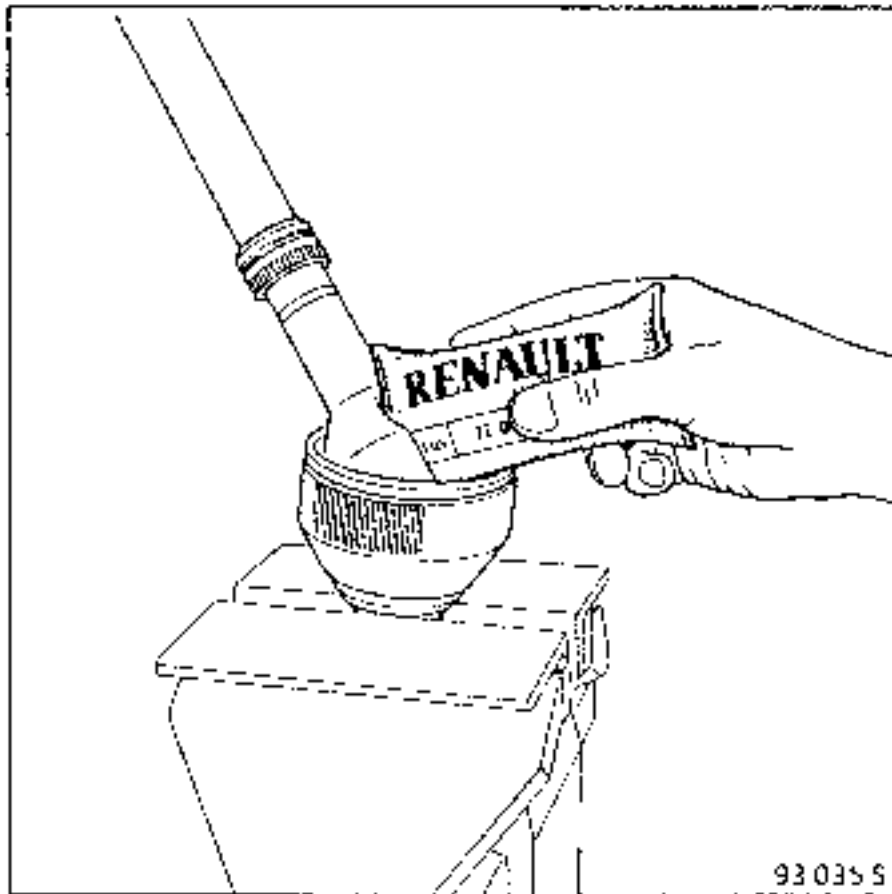

**NOTE :** the volume of grease specified in the "Consumables" section must be observed.

Push the gaiter on, ensuring it clicks into position correctly, first on the stub axle cup groove, then on the tube

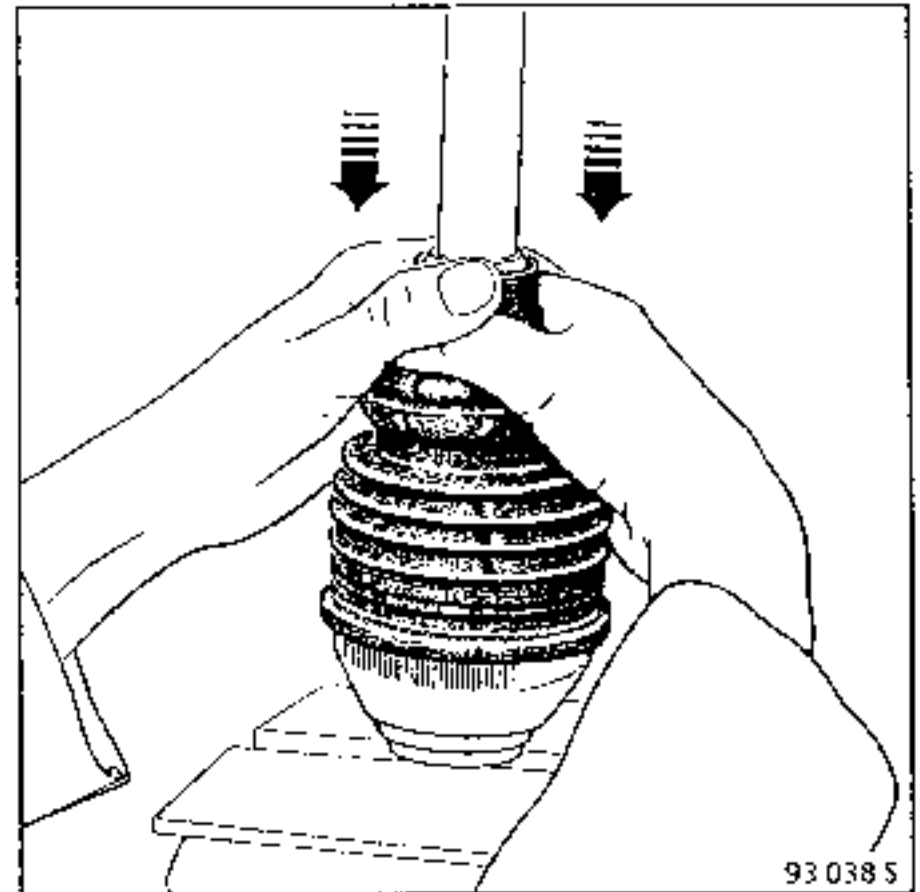
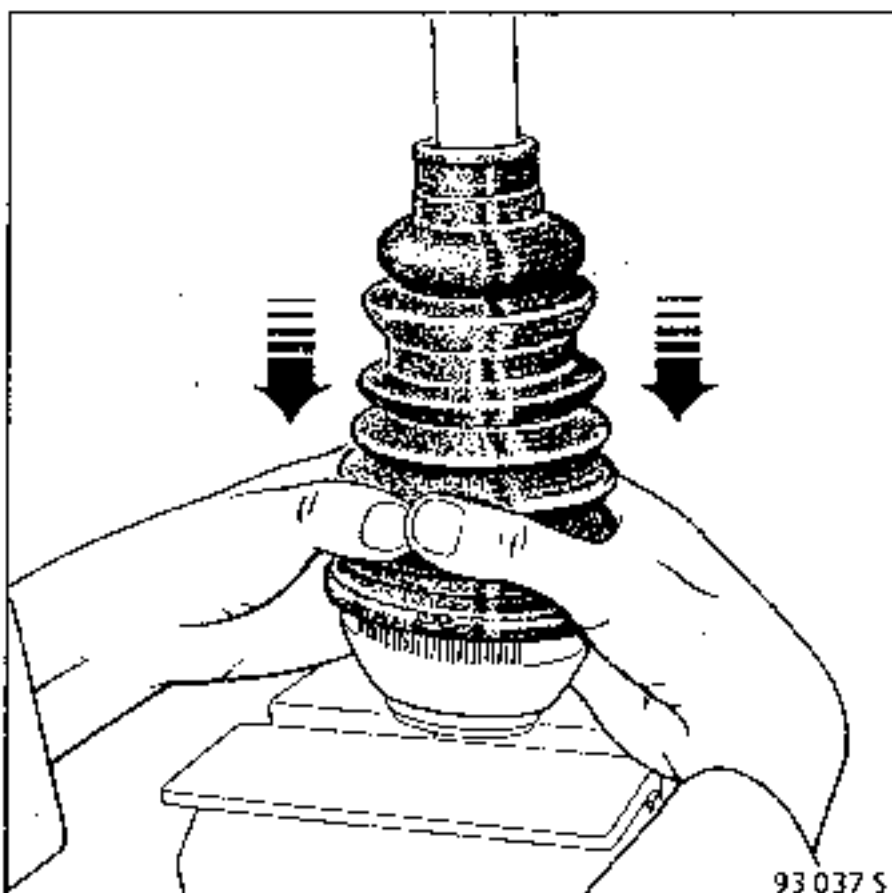

Position the edge of the gaiter correctly.

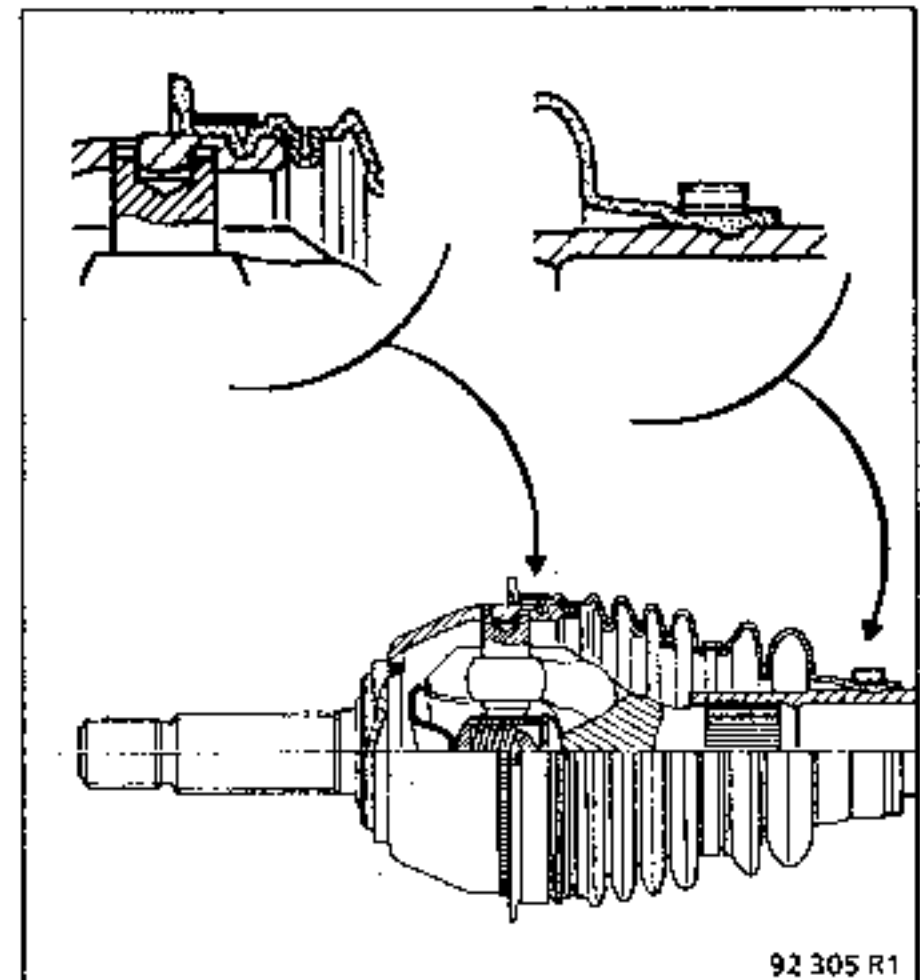

Move the joint by hand to check the two ends are correctly fitted and to ensure the correct amount of air is present in the gaiter.

Fit the collars and tighten them with the appropriate tool for the type of collar supplied in the kit (CAILLAU or OETIKER).

CAILLAU COLLAR

SPECIAL TOOLING REQUIRED	
T.Av. 1168	CAILLAU collar tool for thermoplastic drive shaft gaiters

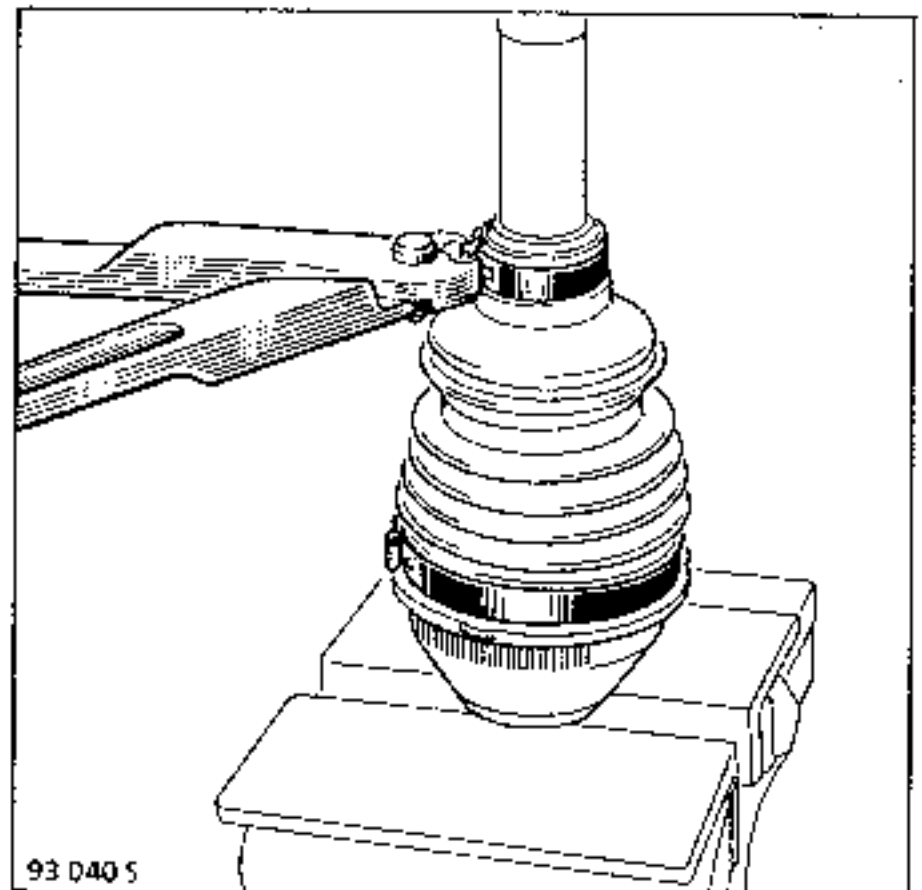
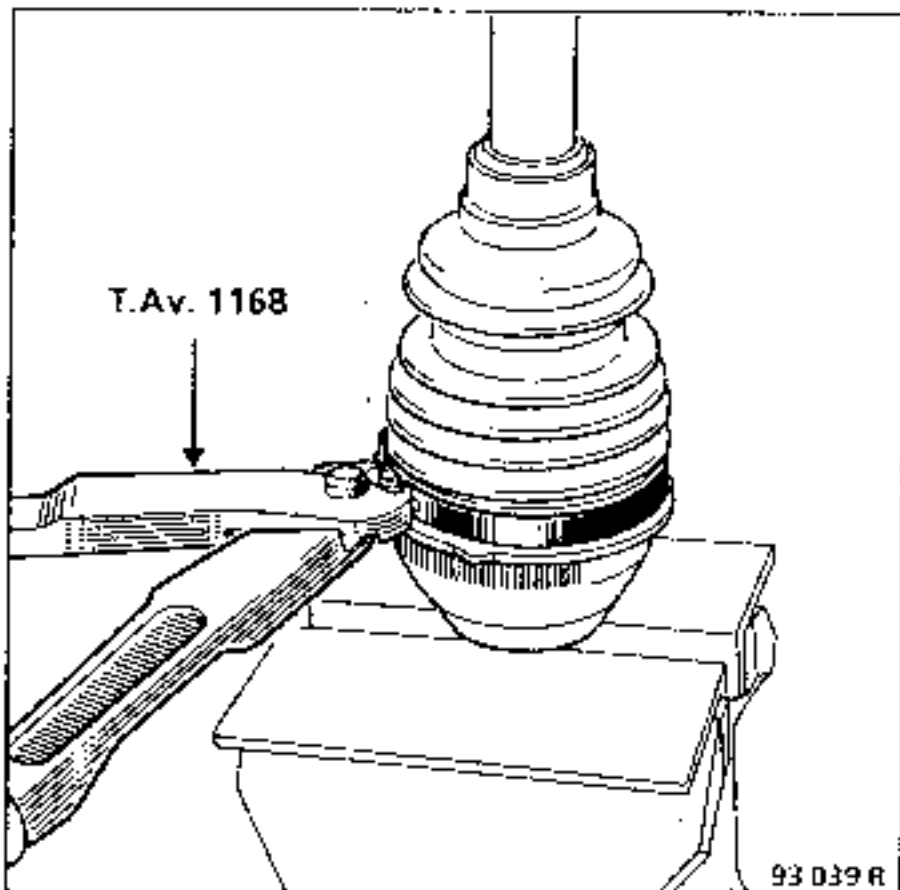
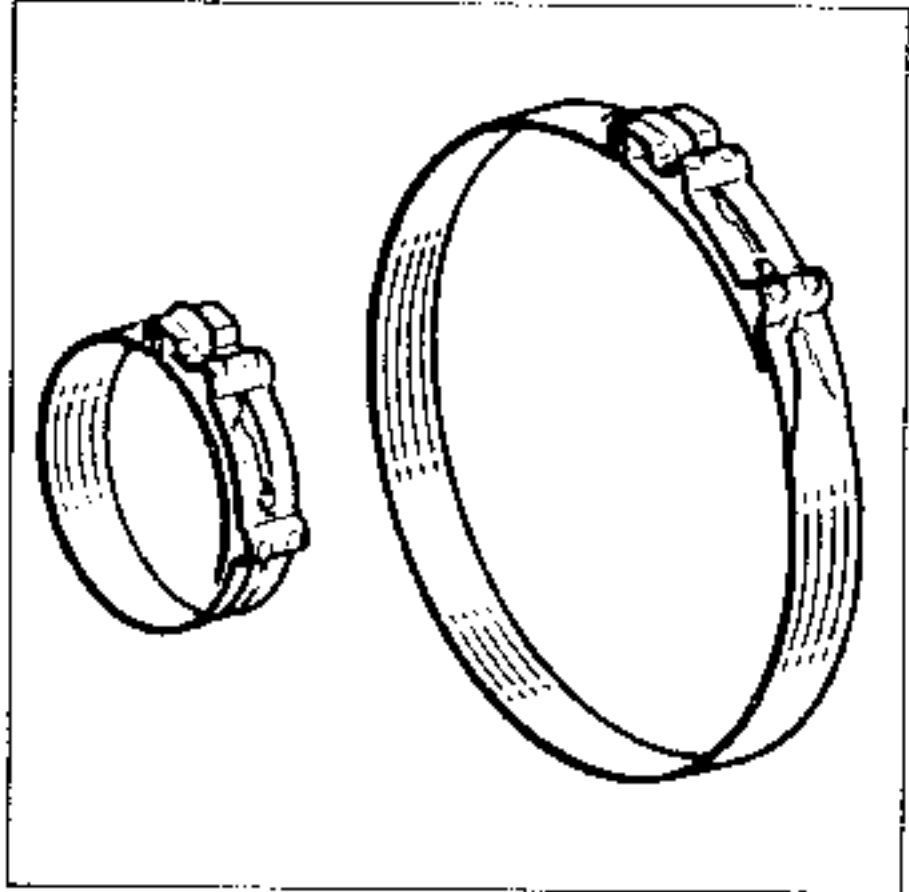

NOTE : CAILLAU collars cannot be re-used.

OETIKER COLLAR

SPECIAL TOOLING REQUIRED

T.Av. 1256 Pliers for fitting OETIKER thermoplastic drive shaft gaiter collars

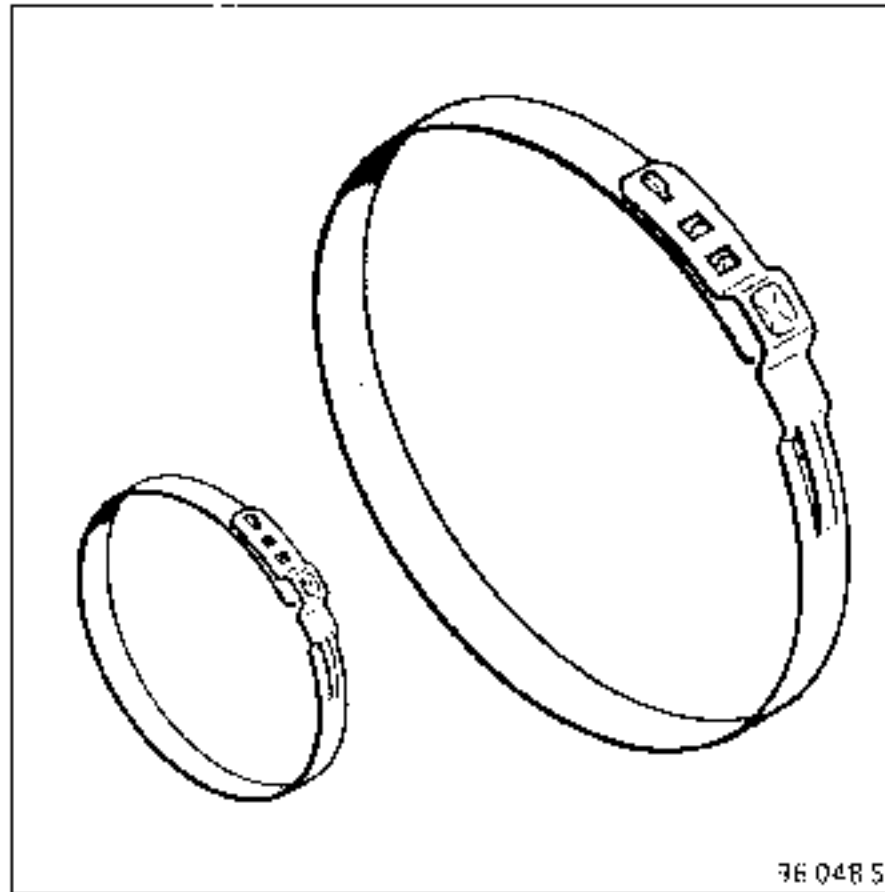

POSITION 1 - Collar pre-crimping and positioning

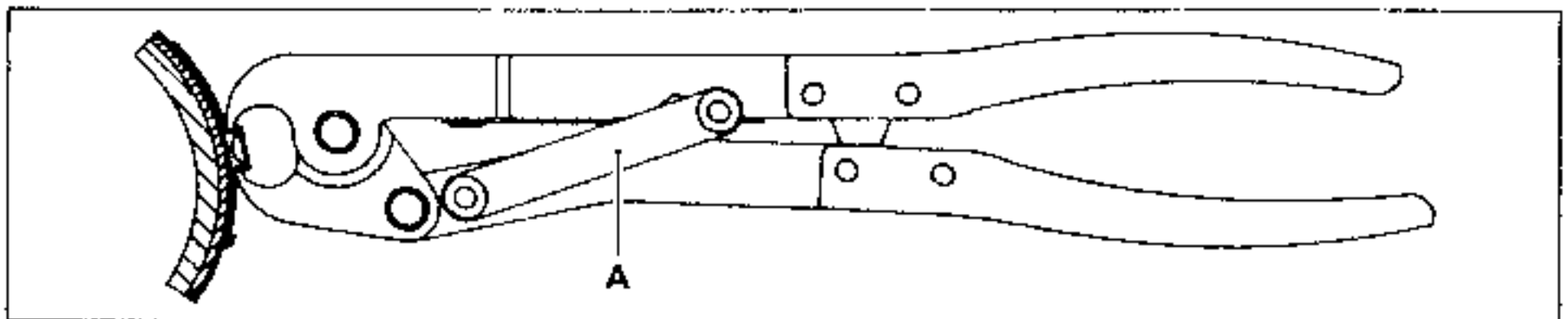

Place bar (A) in the lower notch position and close the pliers. The pre-crimped collar slides onto the gaiter and may then be positioned.

POSITION 2 - Crimping

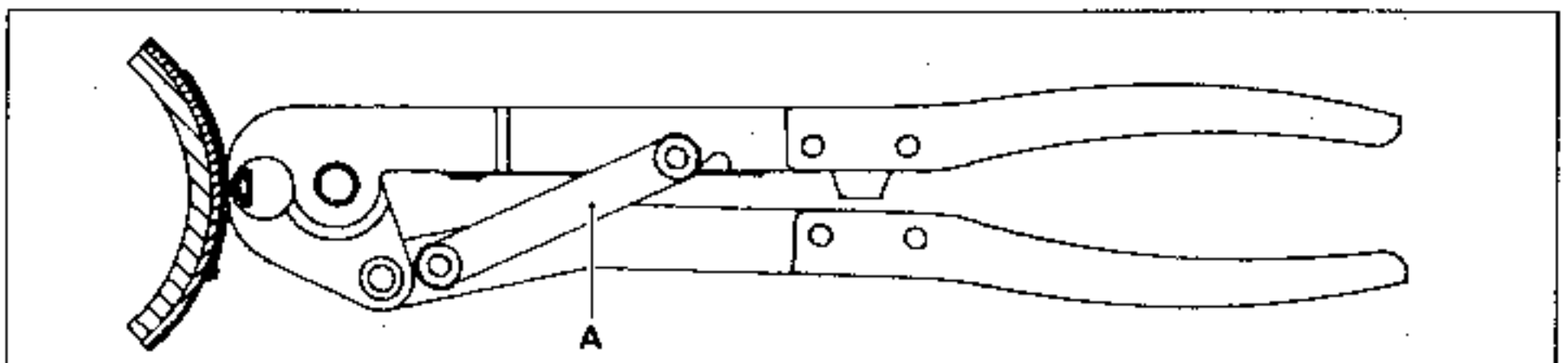

Place bar (A) in the upper notch position and close the pliers

- 1 Yoke
- 2 Spider
- 3 Metal cover
- 4 Retaining spring
- 5 Rubber gaiter
- 6 Retaining ring
- 7 Drive shaft

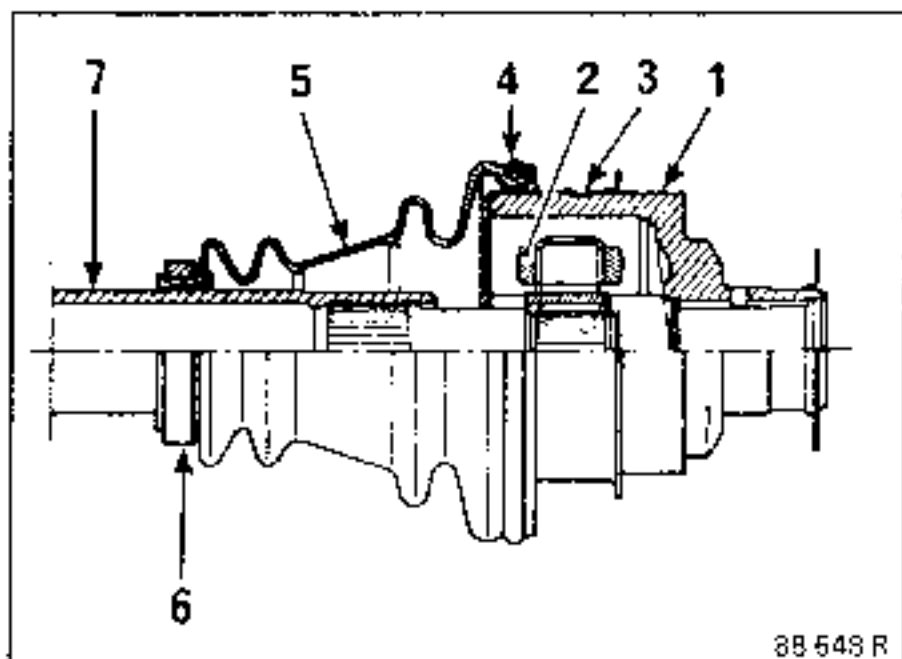

#### REMOVAL

Release the spring (4) which keeps the gaiter in place on the yoke (1)

Cut the gaiter along its length and remove as much grease as possible.

Lift each end of the locking plate (C), then remove the yoke.

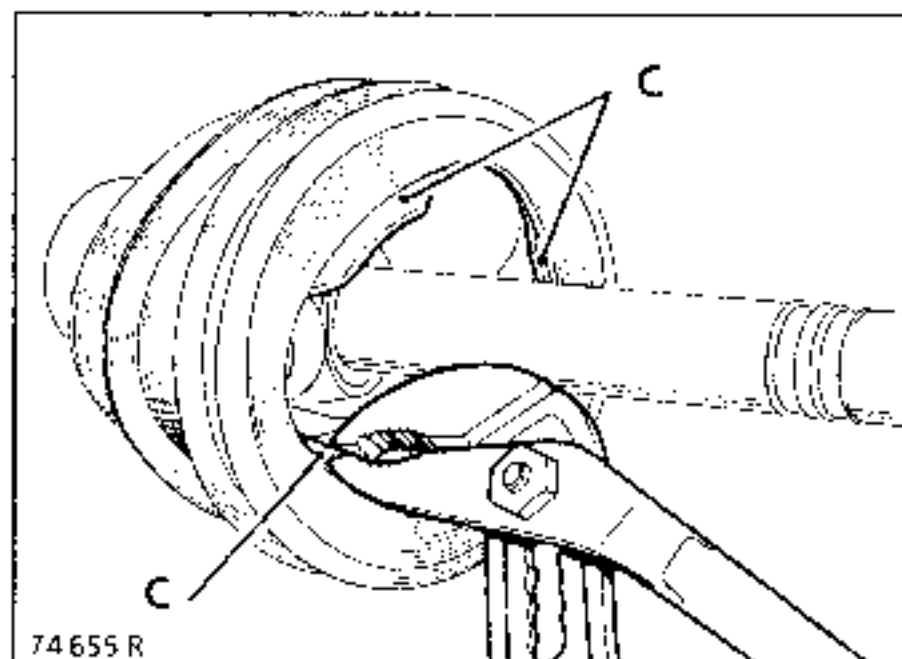

Do not remove the rollers from their bearings since each roller and needle assembly is paired and should not be inverted.

Never use a solvent for cleaning the components.

Depending on assembly, remove the circlips

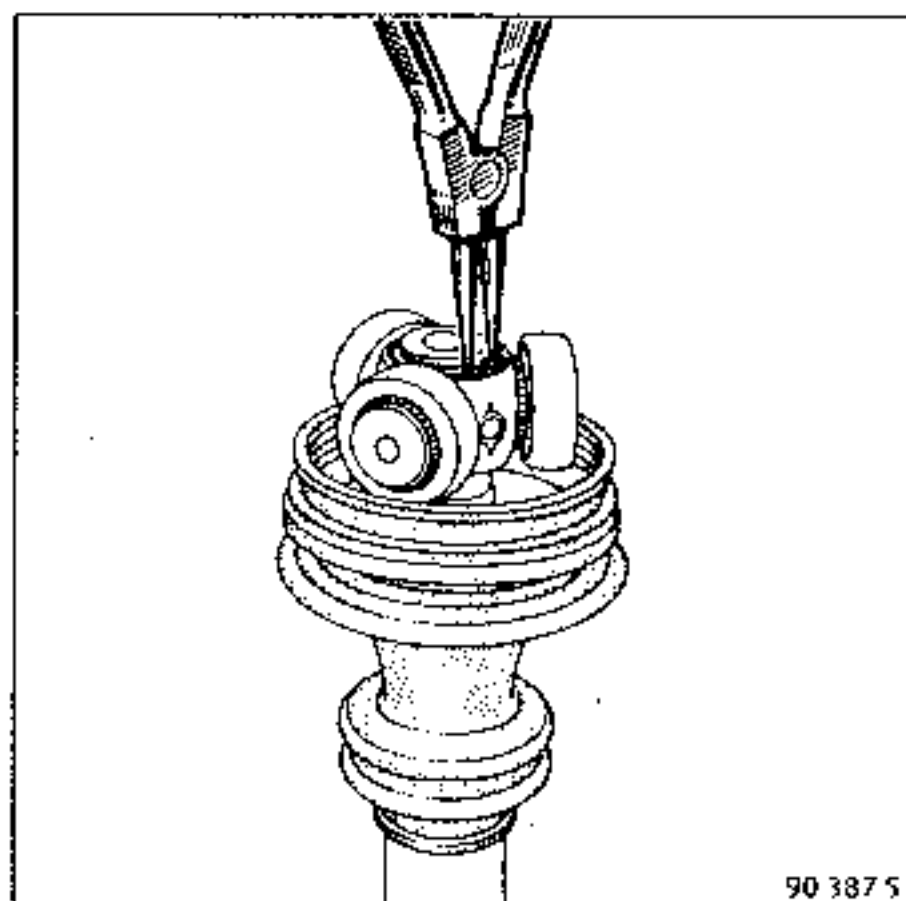
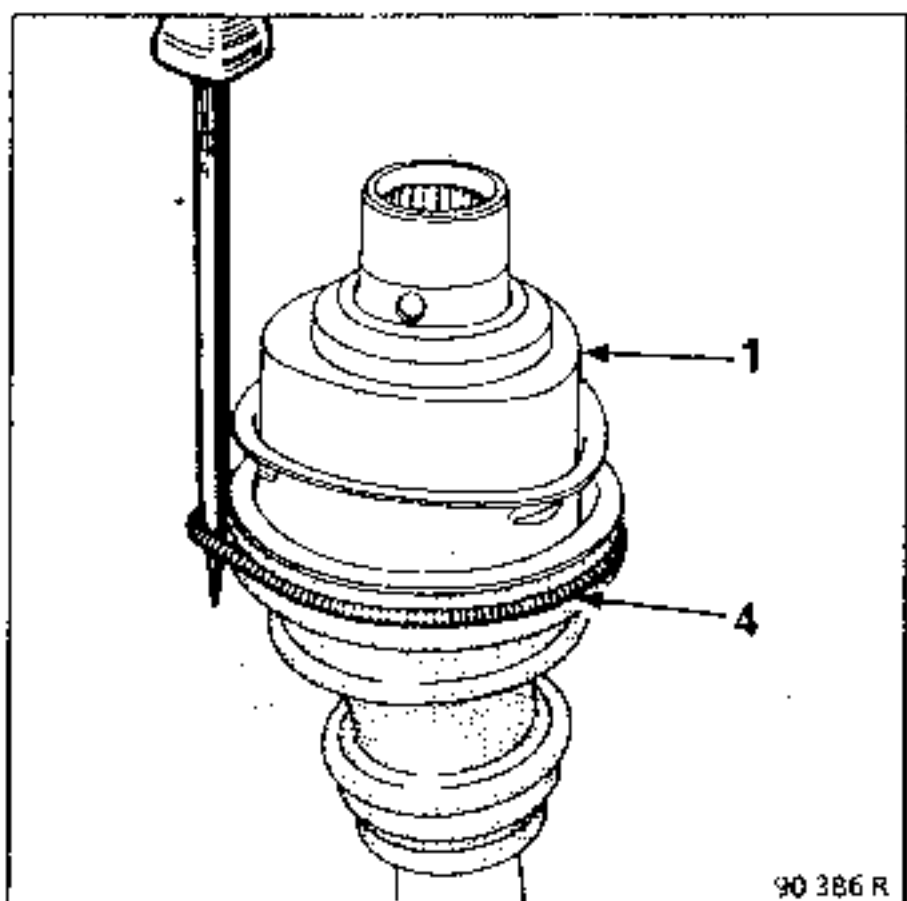

On the press, extract the triaxe component, using an unblocking and extraction tool

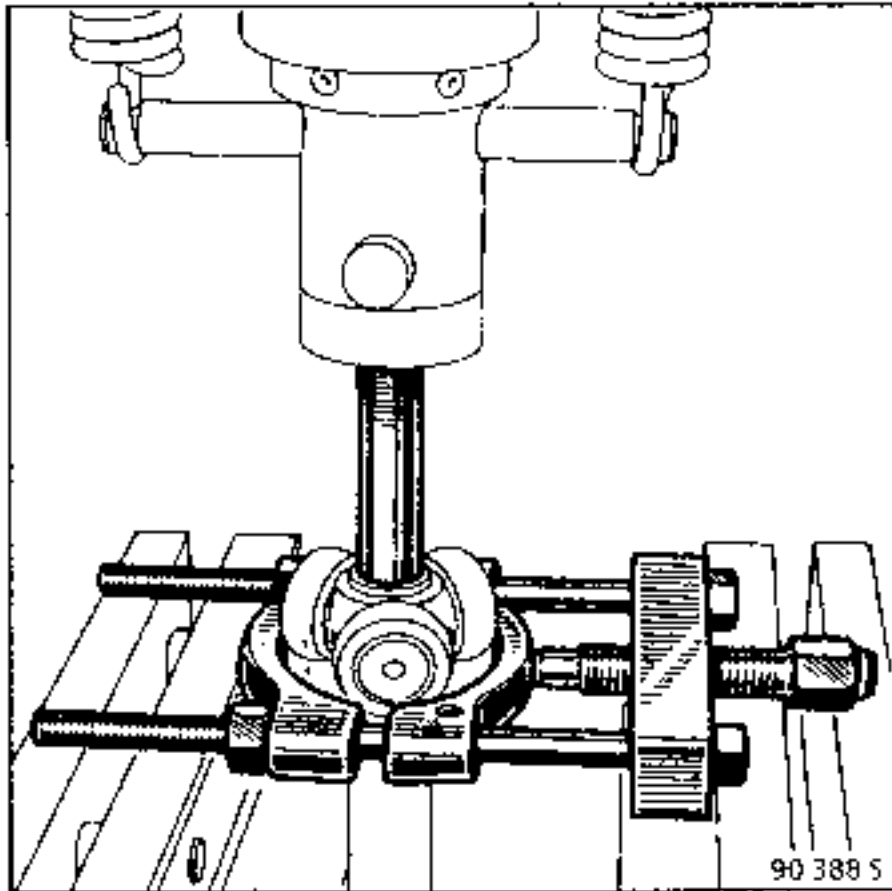

### REFITTING

Lubricate the drive shaft and fit the new ring and gaiter.

Refit the triaxe component on the splined shaft.

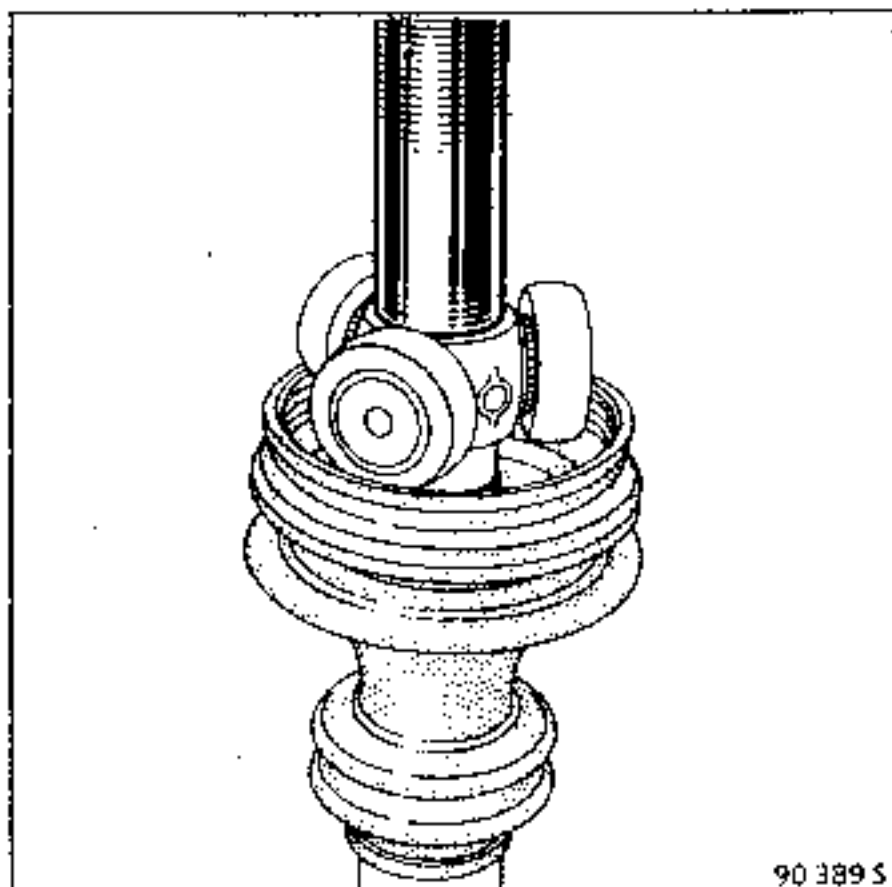

Refit the retaining circlips or crimp three points at 120° to bend over the metal of the splines on the drive shaft

**NOTE :** the volume of grease specified in the "Consumables" section must be observed.

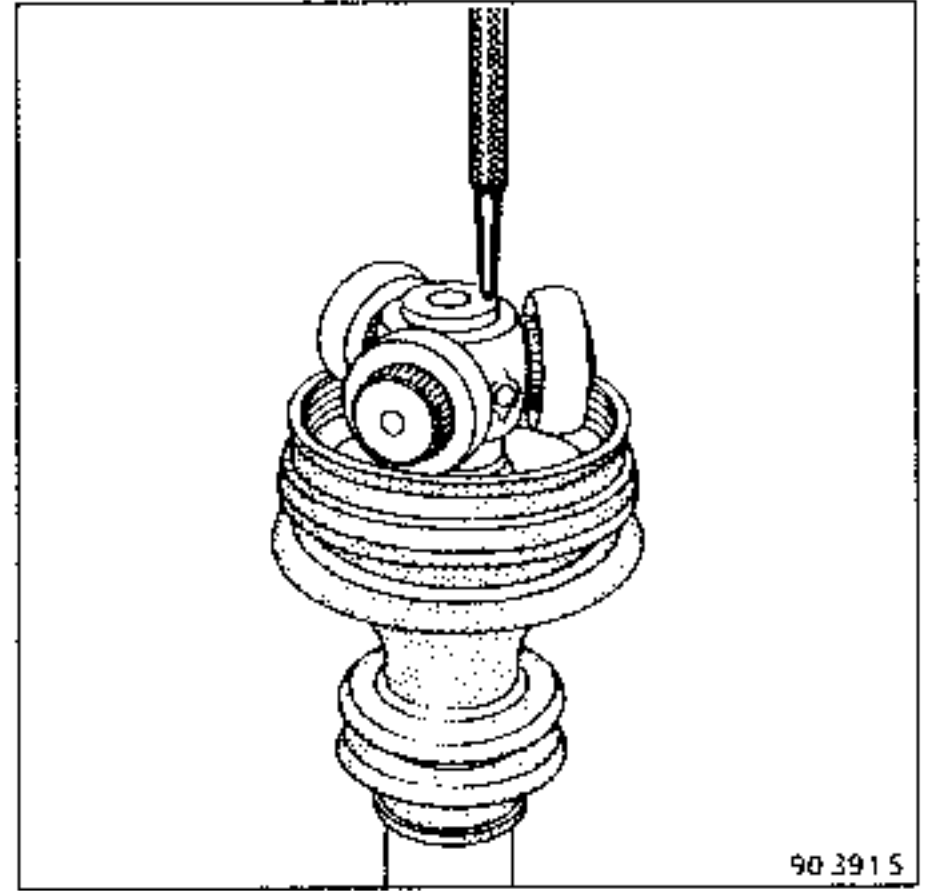

Fit a 2,5 mm shim (B) made according to the diagram, between the locking plate and the yoke.

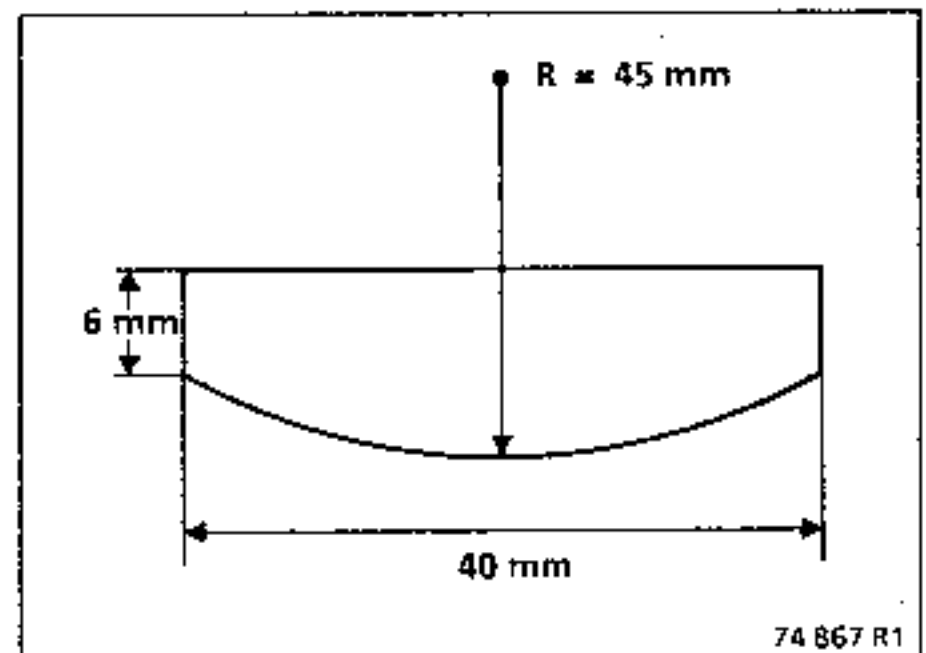



Using a bronze nozzle, carefully bring the plate back into its initial position, then remove the shim (B)

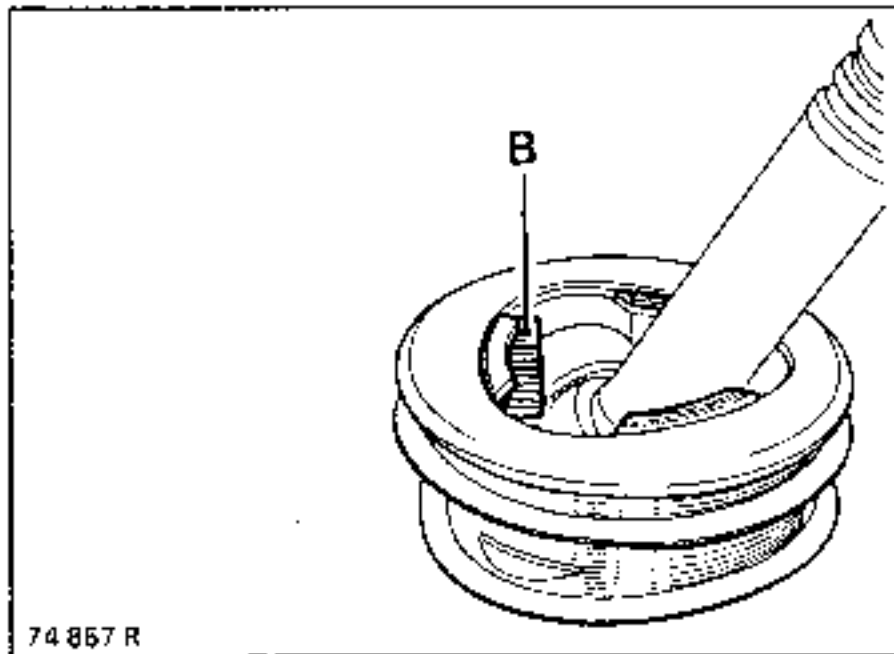

Position the lips of the gaiter in the drive shaft groove and the groove on the metal cover.

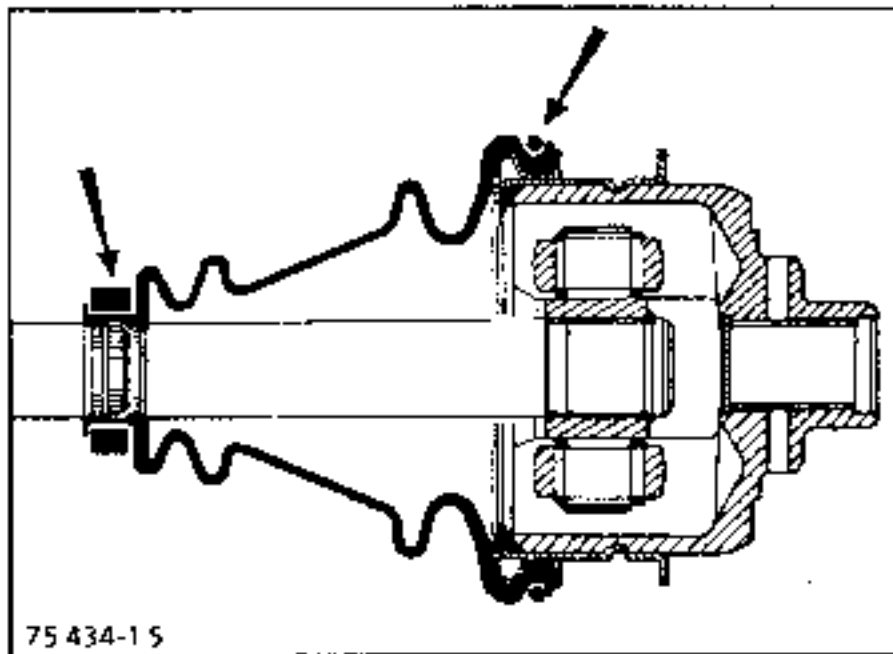

Insert a round - ended rod between the gaiter and the yoke in order to ensure the amount of air inside the gaiter is correct

Bend the assembly to ensure dimension A = 153,5 ± 1 mm (dimension measured from the end of the gaiter to the largest diameter machined face of the yoke).

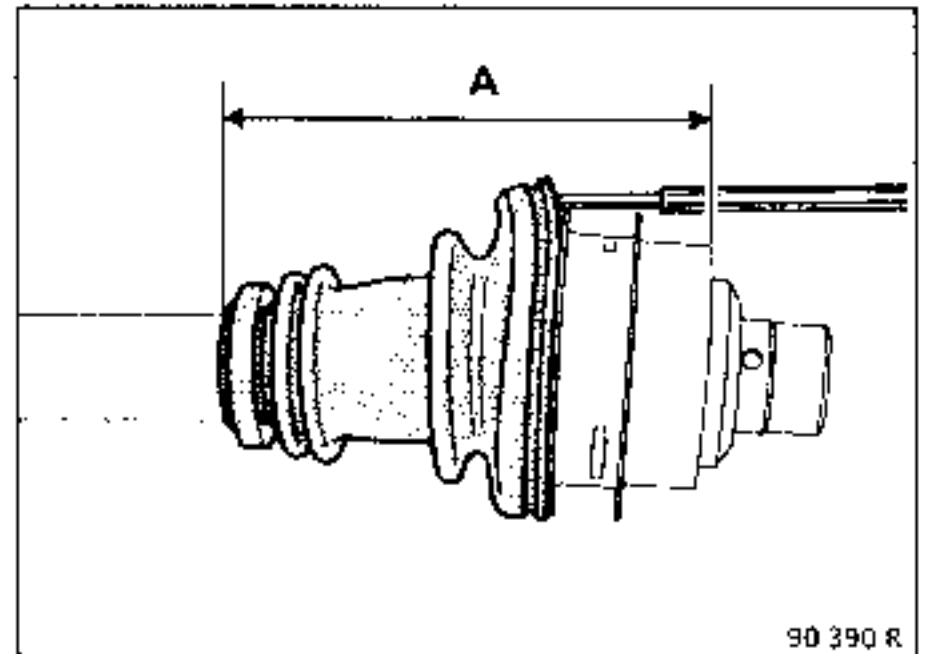

When the assembly is in this position, remove the rod.

Refit the spring and the retaining ring on the gaiter:

- the spring should not be stretched,
- the spring coils should remain in contact with each other after fitting.

## SPECIAL TOOLING REQUIRED

T.Av.944

Mandrel for fitting the bearing  
on the shaft

## REMOVAL

Never use a solvent for cleaning the component parts.

Depending on assembly, remove the circlips.

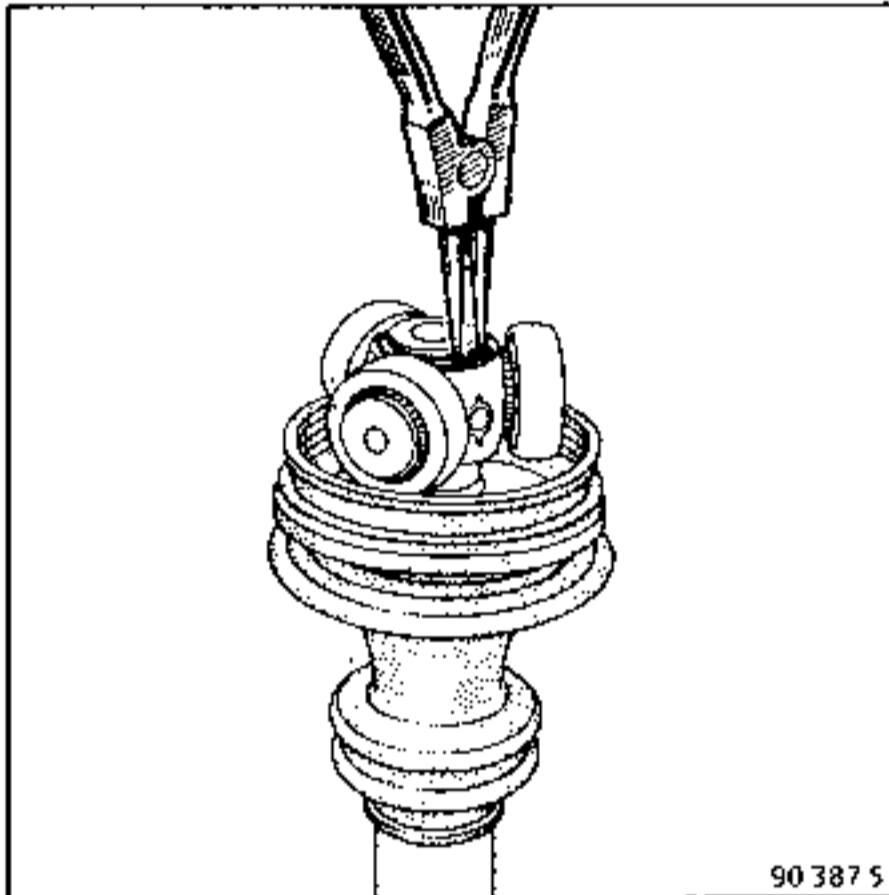

On the press, remove the triaxe component, using an extractor of type Facom U53G.

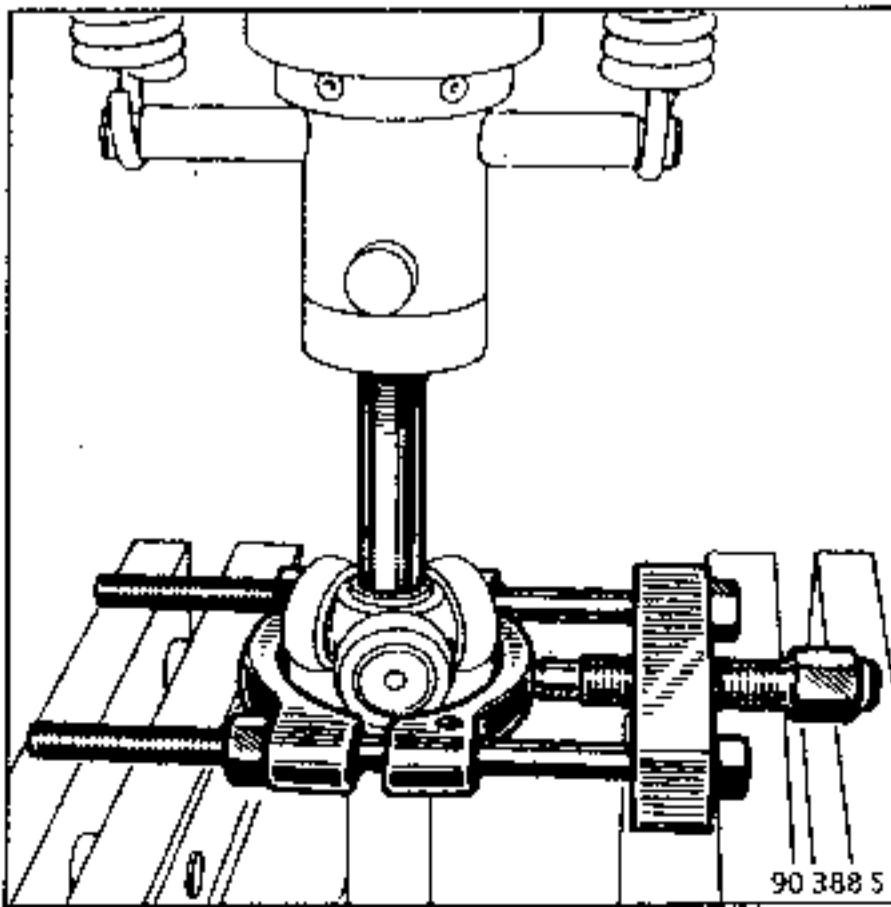

Remove the gaiter and bearing assembly in the same manner as the triaxe component.

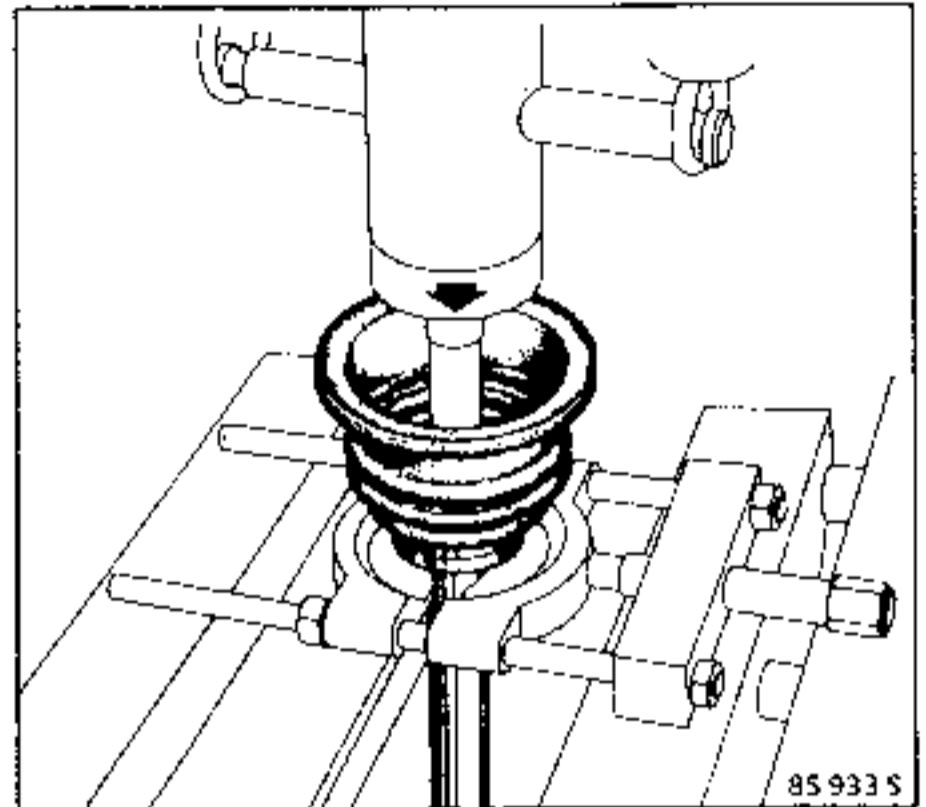

**REFITTING**

To be correctly positioned on the shaft the bearing should be pushed on to give a dimension  $L = 148,5$  mm between the rear part of the bearing and the end of the shaft.

This dimension is obtained using tool T.Av. 944 when the end of the tool is in line with the end of the shaft

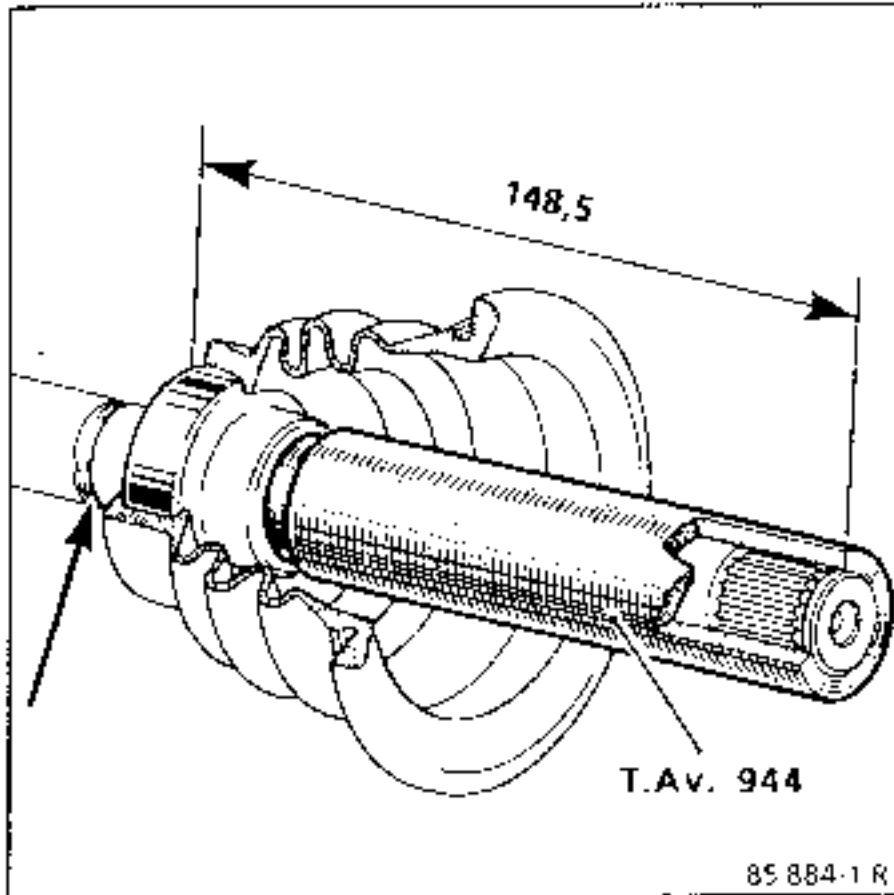

To avoid damaging the bearing which includes a lip seal, which may cause leaks, do not knock the bearing on with a hammer, but use the press to ensure progressive pressure is applied.

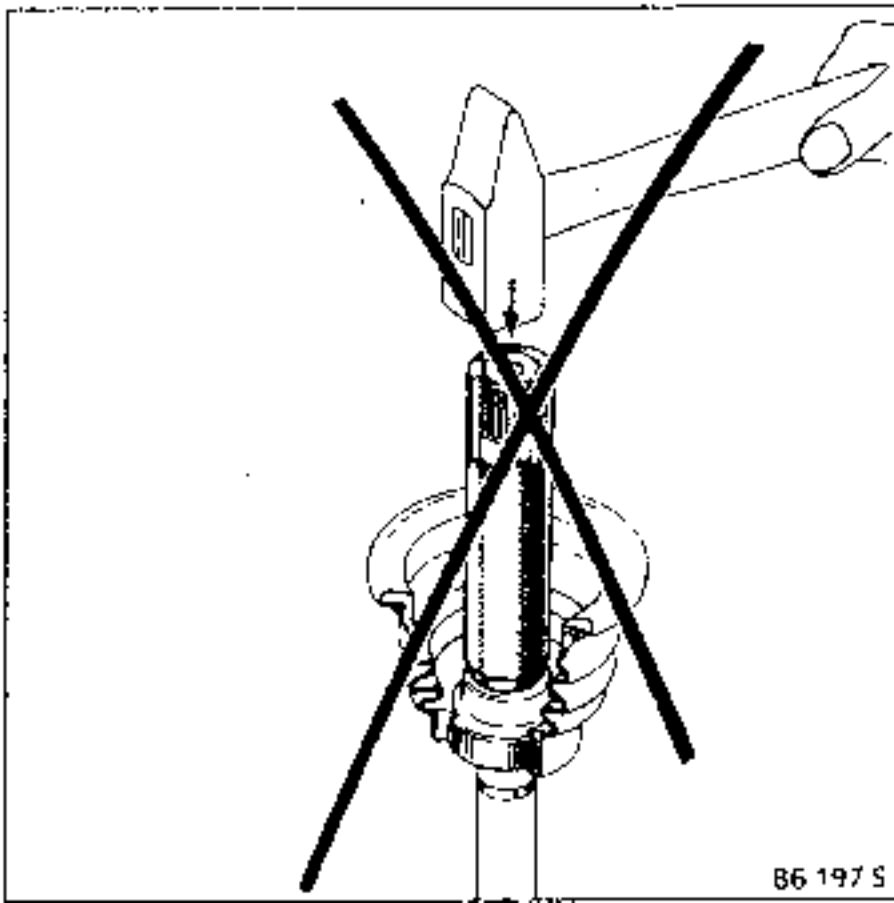

The drive shaft should be held in position on the press by groove (G) using a tool of type Facom U53T to avoid damaging the wheel side seal.

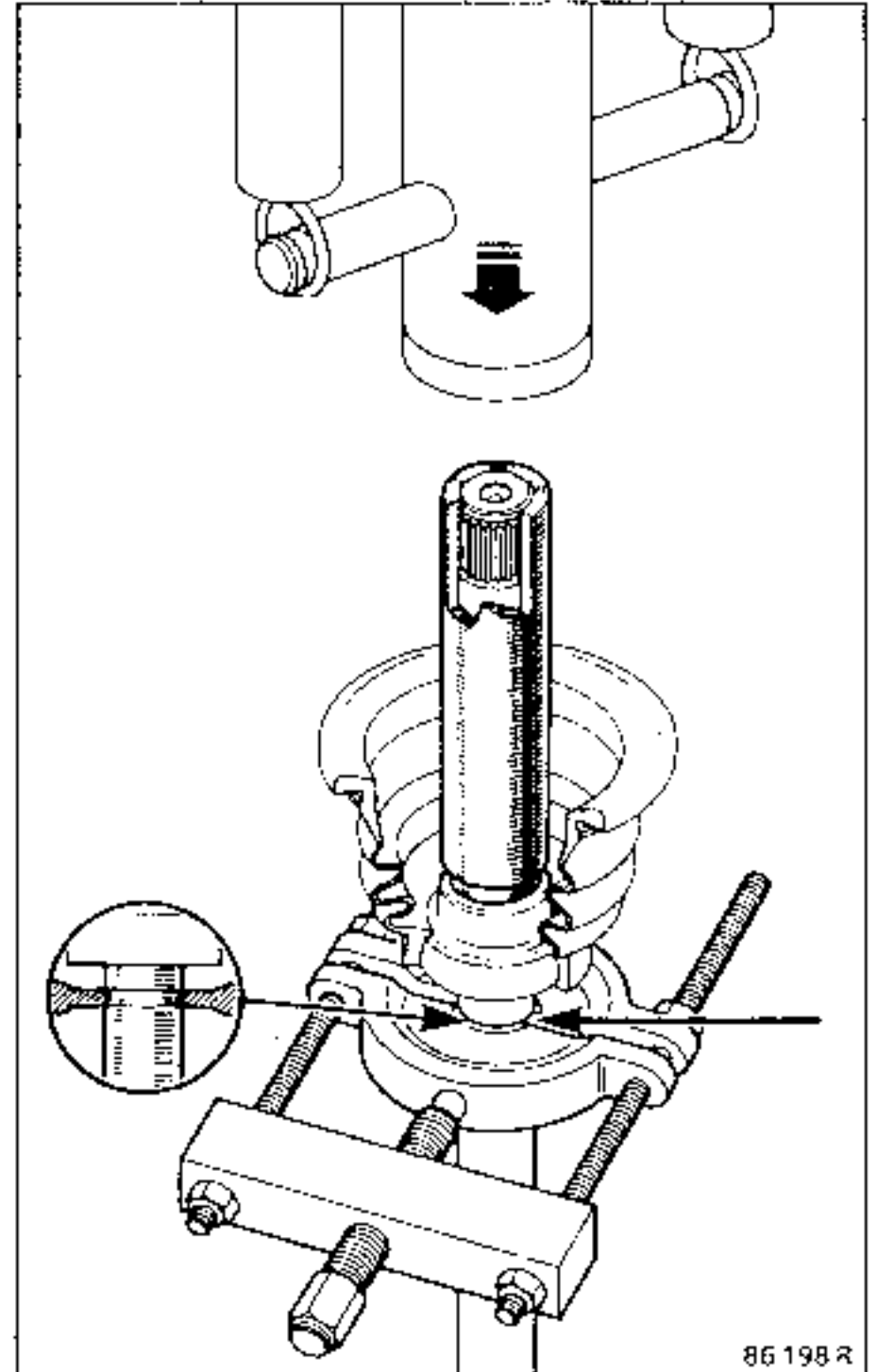

Refit the triaxe component on the splined shaft and replace the retaining circlips (depending on assembly).